

The City of Berwyn is in Phase 5 of the Illinois COVID-19 state mitigation plan. City Hall is open to the public with few restrictions. Vaccinated people do not need to wear masks when inside City Hall. Unvaccinated people need to continue wearing masks. There are no COVID-19 observed capacity limits at this time. Only fire code limits remain. Emergency rules and operations may be re-imposed as required without notice.

PUBLIC PARTICIPATION: PLEASE READ

The Mayor and City Council welcome your in-person attendance at all public meetings as scheduled. The City of Berwyn continues to live stream the Regular City Council meetings on its YouTube page. You may address the City Council in-person during the Open Forum portion of the City Council's agenda. Written comments submitted to the City Clerk received prior to 2:00 p.m. on the day of the meeting will be provided to all elected officials.

A. Pledge of Allegiance and Moment of Silence

B. Open Forum:

C. Approval of Minutes:

1. Committee of the Whole and Public Hearing Meeting of June 22, 2021
2. Regular City Council Meeting of June 22, 2021.

D. Bid Openings:

1. Deferred Item D-1 from June 22, 2021: Contract Award for Depot District Underground Utility Improvement Project to Pan Oceanic.

E. Berwyn Township, Berwyn Health District, Berwyn Development Corporation:

1. BDC: Deferred Item E-1 from June 22, 2021: C-1 Zoning District Recommendation to adopt an Ordinance entitled **An Ordinance Amending Table 1246.04-A (C-1 District Requirements) Within Section 1246.04 (C-1 Neighborhood Mixed-Use District Requirements) of Title 4 (Zoning) of Part Twelve (Planning and Zoning) of the Codified Ordinances of Berwyn Relative to Interior Side Yard Setbacks in the C-1 Neighborhood Mixed-Use Zoning District.**

F. Reports from the Mayor:

1. Resignation and Appointment of a member of the Berwyn Library Board.

G. Reports from the Clerk: Nothing submitted.

H. Zoning Boards of Appeals: Nothing submitted.

I. Reports from the Aldermen, Committees, and Boards:

1. Ald. Ruiz: Four Day Water Outage 1900 & 2100 Ridgeland Avenue.
2. Ald. Ruiz: Implementation of Diversity Commission.
3. Ald. Ruiz: Deferred Item K-19 from June 22, 2021: RE/MAX Partners Summer Fest event request 9/18/2021.
4. Ald. Carmichael: American Legion Annual Picnic event request – 8/7/2021.
5. Ald. Lennon: James Joyce Half Way to St. Patrick's Day event request – 9/25/2021.
6. Ald. Arenella: Approve 2200 Block of Grove Front Yard Sale.

J. Reports from the Staff:

1. CDBG Dir. Mendicino: Recommendation to adopt Resolution entitled: **A Resolution Approving the City of Berwyn's Annual Action Plan for Program Year 2021 for Community Development Block Grant ("CDBG") Funds and for Authorization to Submit Same to the United States Department of Housing and Urban Development ("HUD").**
2. Fire Chief Hayes: Purchase request for E-One Ladder Truck.
3. Police Chief Cimaglia: Request to promote 1 Sergeant to Lieutenant (Vokac replacement).
4. Police Chief Cimaglia: Request to promote 1 Patrol Officer to Sergeant.
5. Police Chief Cimaglia: Request to promote 1 Patrol Officer to Sergeant (Gray replacement).
6. Police Chief Cimaglia: Request to hire 6 Probationary Police Officers from Lateral Eligibility Pool.
7. Police Chief Cimaglia: Purchase of 5 new police vehicles.
8. Public Works Dir Schiller: Approve IEPA Low Interest Loan Agreement for Water Main and Sewer Improvements for the Depot District Utility Project.
9. Library Dir. Sheedy: Purchase request for circulation desks.

K. Consent Agenda:

1. Payroll: 06/23/2021: \$1,334,200.55 – Informational.
2. Payroll: 07/07/2021: \$1,278,943.93 - Informational.
3. Payables: 06/24/21 to 07/14/21 in the amount of \$1,875,324.11 - Informational.
4. Building and Local Improvement Permits - Informational.
5. Finance Dir.: List of Business Licenses Issued May 2021 thru June 2021 – Informational.
6. Finance Dir.: Ordinance Fines Collected by COB May 2021 thru June 2021 \$37,293.00 – Informational.

Berwyn City Council
Regular Meeting Agenda July 13, 2021 continued

7. Finance Dir.: Compliance Tickets Collected by BPD May 2021 thru June 2021 - \$8,510.00 – Informational.
8. Finance Dir.: Adjudication Fines Collected by BPD May 2021 thru June 2021 - \$3,550.00 – Informational.
9. Finance Dir.: Parking Tickets Collected by COB May 2021 thru June 2021 - \$117,880.00 – Informational.
10. Finance Dir.: Seizure & Impound Fees Collected by BPD May 2021 thru June 2021 - \$17,100.00 – Informational.
11. Finance Dir.: Court Fines Collected by the Municipal Dept. of Circuit Court applied May 2021 thru June 2021- \$7,776.11 – Informational
12. Handicapped Parking Application #1351 – 3734 Oak Park Ave – Denial
13. Block Party 2600 Block of Wesley 08/07/21 – City Services/Street Closure Requested.
14. Block Party 1800 Block of Wenonah 08/14/21 - City Services/Street Closure Requested.
15. Block Party 1200 Block of Kenilworth. 08/14/21 RD 08/21/21 - City Services/Street Closure Requested.
16. Block Party 2700 Block of Grove Ave. 08/21/21 RD 08/28/21 - City Services/Street Closure Requested.
17. Event Request: Berwyn Blues Fest – Donnie Biggins/Fitzgerald’s: 9/24/21 through 9/26/21- City Services/Street Closure Requested.
18. Monthly Casual Sales: Maribel Garcia – Break the Silence Foundation: Monthly through Fall 9:00 to 4:00

Committee / Ward Announcements
Adjournment

Margaret Paul, City Clerk

No. of Items: 38



C-1

Minutes of the Berwyn City Council
Committee of the Whole Meeting
June 22, 2021

Mayor Lovero called the Committee of the Whole to Order at 7:00 p.m. The following Aldermen were present: Lennon, Woywod, Leja, Fejt, Pabon, Ruiz, Aranella, and Carmichael.

The first item on the agenda was the Public Hearing on proposed amendments of Table 1246.04-A (C-1 District Requirements) within Section 1246.04 (C-1 Neighborhood Mixed-Use District Requirements), which specifies minimum interior side yard setbacks within the C-1 District, to change the required interior side yard setback from the current ten (10) feet when a residential or non-residential use is adjacent to a residential district or residential use, to three (3) feet when a residential use is adjacent to a residential district or a residential use.

Mayor Lovero recognized Clerk Paul. Clerk Paul confirmed that she posted the Notice of the Public Hearing in City Hall on June 10, 2021. Clerk Paul confirmed receipt of the Chicago Sun Times Certificate of Publication certifying that the Notice of Public Hearing was published in the newspaper on June 5, 2021. Clerk Paul stated that she had not received any inquiries about the proposed amendments. She stated that no one had submitted emailed comments to be read during the hearing.

Mayor Lovero recognized Berwyn Development Corporation Executive Director David Hulseberg. Mr. Hulseberg described the purpose of the proposed zoning amendments.

Mayor Lovero opened the floor for public comment. Alderman Ruiz asked for additional clarification of the purpose of the amendments and what properties would be effected. Discussion ensued. There were no further questions or comments.

Mayor Lovero concluded the Public Hearing portion of the Committee of the Whole at 7:07 p.m.

Mayor Lovero again recognized Mr. Hulseberg. Mr. Hulseberg described the changes being made in the 3000 S Ridgeland development plans following the School District 100 Board vote against the project as previously submitted.

Mr. Hulseberg spoke regarding a Pay as You Go funding request for 6822 Windsor Avenue. This property is the former Capri Duo restaurant. The building owner is seeking funds to improve and update the interior of the restaurant space. Mr. Hulseberg asked if the council members could be polled to determine whether or not he should proceed and work with the business owner on the financing request. Mayor Lovero polled the Aldermen who favored moving forward with the project.

Mayor Lovero asked for a motion to adjourn the Committee of the Whole. Alderman Lennon made the motion, seconded by Alderman Ruiz, to adjourn. The motion carried by a unanimous voice vote. The meeting concluded at 7:25 p.m.

Respectfully submitted,

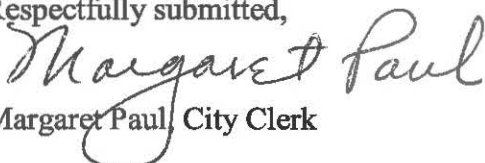
Margaret Paul, City Clerk



C-2

The Berwyn City Council

Minutes of the Regular Meeting of June 22, 2021

Mayor Robert J. Lovero called the Berwyn City Council Regular Meeting to order at 8:00 p.m. Clerk Paul called the roll. The following Aldermen were in attendance and present in chambers: Lennon, Woywod, Leja, Fejt, Pabon, Ruiz, Aranella, and Carmichael.

- A. Attendees rose and recited the Pledge of Allegiance. Mayor Lovero asked for a moment of silence keeping in mind our First Responders.
- B. Open Forum: Mayor Lovero opened the floor for Open Forum. The following members of the public addressed the City Council: Nicolette Penaranda (a copy of the comments submitted for the record), George Lambesis (a copy of the comments submitted for the record), a 4th Ward Resident, Rhonda Majada, Dee McMahon individually and as a member of the Queer Berwyn Collective, Beverly Stewart, and Pat Cagney. The following members of the public submitted emailed comments to the City Council: Sandra Cervenka, Adrian Martinez, and Beth Gunzel.
- C. Approval of Minutes: Ald. Lennon made the motion, seconded by Ald. Fejt, to amend the Minutes of June 8, 2021 in the Open Forum section based upon the comments made during this evening's Open Forum and approve the amended Minutes as follows:
 - *As requested by George Lambesis: remove the Clerk's description of his remarks as criticizing Ald. Pabon.*
 - *As requested by Dee McMahon: strike offensive term "transsexual" to be replaced by the term "transgendered" and identify the person speaking on behalf of Queer Berwyn Collective on June 8, 2021 as Joseph Klomes.*

The motion to approve the Minutes as Amended carried by a unanimous voice vote.

- D. Bid Openings: Ald. Ruiz made the motion, seconded by Ald. Lennon, to defer Item D-1 Bid Award for Construction of the Depot District Underground Utility Improvements Project to the next council meeting. The motion carried by unanimous voice vote.
- E. Ald. Ruiz made the motion, seconded by Ald. Lennon, to defer Item E-1 to the July 13, 2021 agenda. The motion carried by a unanimous voice vote.
- F. Ald. Fejt made the motion, seconded by Ald. Lennon, to concur with the appointment of Cynthia M. Hayes to the 9-1-1 Board to fulfill the term vacated by Richard Leja. The motion carried by a unanimous voice vote.
- G. Ald. Lennon made the motion, seconded by Ald. Fejt, to **adopt the Resolution** entitled: **A Resolution to Release Closed Session Minutes**, direct the Corporate Authorities to

affix the necessary signatures and place it on its way to passage. The motion carried by a unanimous roll call vote.

- H. H-1: Ald. Fejt made the motion, seconded by Ald. Lennon, to **adopt the Ordinance entitled: An Ordinance Approving a Preliminary and Final Plan for a Revised Planned Development/Special Use at the Address Commonly Known as 3000 S. Ridgeland Avenue – Kasper Development LLC Ridgeland**, direct the Corporate Authorities to affix the necessary signatures and place it on its way to passage. Clerk Paul called the roll. The motion carried with six Aldermen voting AYE and two voting NAY.
- H-2: Ald. Fejt made the motion, seconded by Ald. Lennon, to **adopt the Resolution entitled: A Resolution Approving and Accepting a Revised Plat of Subdivision to Resubdivide the Property Commonly Known as 3000 S. Ridgeland Avenue in the City of Berwyn, County of Cook-Ridgeland Estates**, direct the Corporate Authorities to affix the necessary signatures and send it on its way to passage. Clerk Paul called the roll. The motion carried with six Aldermen voting AYE and two Aldermen voting NAY.
- I. I-1: Ald. Lennon made the motion, seconded by Ald. Fejt, to accept Treas. Reyes' communication as informational. The motion carried by a unanimous voice vote.
- I-2: Ald. Ruiz made the motion, seconded by Ald. Fejt, to approve the submitted event request and authorize city services as requested. The motion carried by a unanimous voice vote.
- I-3 Ald. Lennon made the motion, seconded by Ald. Fejt, to approve his Annual Berwyn Pride Walk event request and authorize city services as requested. The motion carried by a unanimous voice vote.
- J. J-1: Ald. Lennon made the motion, seconded by Ald. Woywod, to approve the settlement of 17 WC025688 for \$12,499.78 as submitted. The motion carried by a unanimous roll call vote.
- J-2: Ald. Lennon made the motion, seconded by Ald. Woywod, to **adopt the Ordinance entitled: An Ordinance Amending Chapter 804, Section 804.06 of the Code of Ordinances of the City of Berwyn, Regarding Carry Out Liquor for the City of Berwyn, County of Cook, State of Illinois**, direct the Corporate Authorities to affix the necessary signatures and place it on its way to passage. The motion carried by a unanimous roll call vote.
- J-3: Ald. Leja made the motion, seconded by Ald. Lennon, to approve Fire Chief Hayes' to contact the Police and Fire Commission for the next eligible qualified candidate on the Firefighter/Paramedic list. The motion carried by a unanimous voice vote.
- J-4: Mayor Lovero recognized Public Works Dir. Schiller who explained the three IEPA loans for the Berwyn Depot District Underground Utility Improvement Project on which he was seeking council approval. Ald. Ruiz made the motion, seconded by Ald. Lennon to approve the following loans: L175289 for \$7,763,139.58 at an interest rate of 1.35% and repayment period of 20 years, L175290 for \$7,409,874.99 at an interest rate of

1.01% and repayment period of 20 years, and L175902 for \$466,755.17 at 100% principal forgiveness. The motion carried by a unanimous roll call vote.

J-5: Ald. Lennon made the motion, seconded by Ald. Woywod, to **adopt the Resolution entitled: Resolution Accepting a Grant from the Illinois Housing Development Authority’s Abandoned Residential Property Municipal Relief Program**, direct the Corporate Authorities to affix the necessary signatures and send it on its way to passage. The motion carried by a unanimous roll call vote.

J-6: Ald. Lennon made the motion, seconded by Ald. Fejt, to approve Library Dir. Sheedy’s request to solicit bids for a LED digital sign. The motion carried by a unanimous voice vote.

K. Items K-1 through K-19:

K-19: Ald. Ruiz made the motion, seconded by Ald. Fejt, to pull Item K-19 from the Consent Agenda. The motion carried by a unanimous voice vote. Ald. Ruiz made the motion, seconded by Ald. Fejt, to defer the Item to the July 13, 2021 agenda. The motion carried by a unanimous voice vote. Ald. Lennon made the motion, seconded by Ald. Fejt, to approve the remaining items on the Consent Agenda by omnibus designation. The motion carried by a unanimous voice vote.

There being no further business before the council, Ald. Lennon made the motion, seconded by Ald. Ruiz, to adjourn. The motion carried by a unanimous voice vote.

The meeting adjourned at 9:00 p.m.

Respectfully submitted,

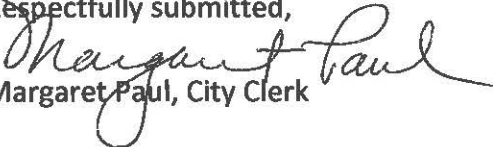
Margaret Paul, City Clerk



A Century of Progress with Pride

June 22, 2021

To: Mayor Robert J. Lovero
Members of the Berwyn City Council

Re: Recommended Contract Award for Construction of the Depot District Underground Utility Improvements Project

D-1
6/22/21
Deputy FO
7/13/21
DISPOSITION
DATE
ITEM NO.

Project Background

Terra Engineering was retained by the City to perform design engineering services for a two-phase construction project in the City’s Depot District.

- Phase 1 - Utility Improvements
- Phase 2 - Streetscape Improvements

The City has completed the design and bidding for Phase 1, including water main replacement, sewer rehabilitation, new water services and the restoration to any affected landscaped, concrete, or paved areas.

The project boundaries are:

- Windsor Avenue and Stanley Avenue from Harlem Avenue to Ridgeland Avenue
- Oak Park Avenue from Ogden Avenue to 30th Street
- Grove Avenue from 34th Street to 32nd Street

Construction of Phase 1 is scheduled to start in April 2021 with completion in the summer of 2022.

Project Funding

Construction is being funded through a low interest loan provided by the Illinois Environmental Protection Agency (IEPA). The procurement process is subject to IEPA regulations contained in the Procedures for Issuing Loans from the Public Water Supply Loan Program.

“Any contract or contracts awarded under this invitation for bids are expected to be funded in part by a loan from the Illinois Environmental Protection Agency (Illinois EPA). Neither the State of Illinois nor any of its departments, agencies, or employees is or will be a party to this invitation for bids or any resulting contract. The procurement will be subject to regulations contained in the Procedures for Issuing Loans from the Public Water Supply Loan Program (35IAC Part 662), the Davis-Bacon Act (40 USC 276a through 276a-5) as defined by the United States Department of Labor, the Employment of Illinois Workers on Public Works Act (30 ILCS 570), and the “Use of American Iron and Steel” requirements as contained in Section 436 of H.R. 3547, The Consolidated Appropriations Act, 2014. This procurement is also subject to the loan recipient’s policy regarding the increased use of disadvantaged business enterprises.”

Procurement Process

The procurement process for this project consisted of:

- I. **Invitation to Bid:** Terra Engineering publicly advertised on December 10, 2020. The invitation was advertised in the local paper and on various construction publications with an extended 45 days to meet the IEPA requirements.
- II. **Mandatory Pre-Bid Meeting (Virtual):** Interested bidders attended a mandatory pre-bid meeting held on January 12th at 1:00pm. Terra Engineering presented a summary of the utility project and funding requirements. Interested bidders were able to submit questions until noon on January 29, 2021.
- III. **Bid Due Date:** All bids were due to the City Clerks Office on February 5, 2021 by 10:00am.
- IV. **Bid Opening:** On February 5, 2021 at 11:00am all bids were opened and read aloud by Robert Schiller on a virtual platform.
- V. **Bid Comparison Summary:** A bid tabulation was created to compare and align all bidders. Bid documents were reviewed for compliance with City and IEPA requirements. The bid summary will be available on the City’s website once approved by City Council.
- VI. **Reference Checks:** The project team contacted 13 references that were provided by Pan Oceanic Engineering, Co. The references provided feedback on Pan Oceanic Engineering Co. as a firm and on the staffing being proposed for the project. All references came back with positive reviews.

Award Recommendation

The City of Berwyn Project Team has reviewed the bid tabulations and concurs with Terra Engineering’s recommendation to award to Pan Oceanic for \$13,869,069.00.

<u>Contractor</u>	<u>Location</u>	<u>As Read Bid</u>
Pan Oceanic Engineering, Co	Chicago, IL	\$13,869,069.00
Joel Kennedy Construction	Chicago, IL	\$15,781,122.00
Austin Tyler Construction	Elwood, IL	\$17,984,454.46
Martam	Elgin, IL	\$18,195,338.80
Boulder Contractors	Deerfield, IL	\$18,236,384.80
Benchmark Construction	Bartlett, IL	\$19,648,591.60

Engineer’s Estimate **\$11,765,090.00**

Respectfully,



Robert Schiller
Director of Public Works



MEMORANDUM

ITEM NO. E-1
DATE 6/22/21
DISPOSITION Refer to 7-13-21

TO: Mayor Robert Lovero, Members of the City Council and Ruth Siaba Green, City Administrator

FROM: David Hulseberg, Executive Director/CEO

Date: June 17, 2021

RE: C-1 Zoning District Change

Staff is recommending that the City of Berwyn modify the existing code in the C-1 Neighborhood Mixed-Use Zoning District when a residential use is adjacent to a residential district or a residential use.

Staff proposes the following amendments:

- Amendment of Table 1246.04-A. (C-1 District Requirements) within Section 1246.04 (C-1 Neighborhood Mixed-Use District Requirements), which specifies minimum interior side yard setbacks within the C-1 District to change the required interior side yard setback from the current ten (10) feet when a residential or non-residential use is adjacent to a residential district or residential use, to three (3) feet when a residential use is adjacent to a residential district or a residential use.

The purpose of this amendment is to remove the need for variations when residential development seeks to be constructed adjacent to residential in the C-1 District. The minimum lot width in the C-1 is 30' with a requirement of a 10' setback if adjacent to residential use or residential districts. If a 30' vacant lot was to be developed as a residential use in a C-1 District and it was adjacent to residential uses on both sides, it would require a 10' setback on each side of it leaving the ability to build a 10' wide residential use. Rather than to facilitate variations for this type of situation, changing the code is more practical. The code change would require only a 3' setback in those instances.

Recommendation: The BDC recommends that City Council approve the 3' setback requirement in the C-1 District when abutting residential use or residential districts.

ORDINANCE NO. _____

AN ORDINANCE AMENDING TABLE 1246.04-A. (C-1 DISTRICT REQUIREMENTS) WITHIN SECTION 1246.04 (C-1 NEIGHBORHOOD MIXED-USE DISTRICT REQUIREMENTS) OF TITLE 4 (ZONING) OF PART TWELVE (PLANNING AND ZONING) OF THE CODIFIED ORDINANCES OF BERWYN RELATIVE TO INTERIOR SIDE YARD SETBACKS IN THE C-1 NEIGHBORHOOD MIXED-USE ZONING DISTRICT

WHEREAS, the City of Berwyn (the “City”) is a home rule unit of local government as is provided by Article VII, Section 6 of the Illinois Constitution of 1970 and, as such, may exercise various powers and perform numerous functions pertaining to its government and affairs in any manner not otherwise prohibited by law; and

WHEREAS, the City has proposed an amendment (the “Application”) to the text of Table 1246.04-A. (C-1 District Requirements) within Section 1246.04 (C-1 Neighborhood Mixed-Use District Requirements) of Title 4 (Zoning) of Part Twelve (Planning and Zoning) of the Codified Ordinances of Berwyn (the “Zoning Code”) relative to permitted interior side yard setbacks in the C-1 Neighborhood Mixed-Use Zoning Districts when a residential use is adjacent to a residential district or a residential use (the “Proposed Text Amendment”); and

WHEREAS, the Application has been processed in accordance with the Zoning Code, as amended, and has been referred to the City Council of the City (“City Council”) for a public hearing and consideration; and

WHEREAS, on _____, 2021, the City Council held a public hearing on the Application pursuant to notice thereof given in the manner required by law; and

WHEREAS, the City Council of the City, having duly considered all of the testimony, evidence, materials, facts and circumstances affecting the Application, find that the Application satisfies the standards set forth in Section 1252.03(E)(3) of the Zoning Code relating to Zoning Code text amendments.

WHEREAS, pursuant to the authority granted under Division 13 of the Illinois Municipal Code (65 ILCS 5/11-13-1 et seq.), and its home rule powers and authority, pursuant to Article VII, Section 6 of the Illinois Constitution of 1970, the City Council of the City approve the Proposed Text Amendment to the Zoning Code set forth below, and find the adoption of the Proposed Text Amendment to be in the best interests of the City.

NOW, THEREFORE, BE IT ORDAINED, by the City Council of the City of Berwyn, Cook County and State of Illinois, as follows:

SECTION 1: Incorporation. Each whereas paragraph set forth above is incorporated by reference into this Section 1.

SECTION 2: Text Amendment Approved. Line F. of Table 1246.04-A. (C-1 District Requirements) within Section 1246.04 (C-1 Neighborhood Mixed-Use District Requirements), which

specifies minimum interior side yard setbacks within the C-1 District, is amended to read in its entirety as follows:

<p>1</p>	<p>Minimum Interior Side Setback</p>	<p>0 ft; 10 ft <u>for non-residential uses</u> if residential district <u>or residential use is adjacent</u> or if residential use; <u>3 ft. for residential uses if residential district or residential use is adjacent</u></p>
----------	--------------------------------------	---

SECTION 3: No Other Changes. Except as to the Zoning Code Text Amendment set forth above in this Ordinance, all Chapters and Sections of the Codified Ordinances of Berwyn, as amended, shall remain in full force and effect.

SECTION 4: Severability and Repeal of Inconsistent Ordinances. Each section, paragraph, clause and provision of this Ordinance is separable, and if any section, paragraph, clause or provision of this Ordinance shall be held unconstitutional or invalid for any reason, the unconstitutionality or invalidity of such section, paragraph, clause or provision shall not affect the remainder of this Ordinance, nor any part thereof, other than that part affected by such decision. All ordinances, resolutions or orders, or parts thereof, in conflict with the provisions of this Ordinance are to the extent of such conflict hereby repealed.

SECTION 5: Effective Date. This Ordinance shall be in full force and effect from and after its passage, approval, and publication in pamphlet form in the manner provided by law.

PASSED this ____ day of _____ 2021.

AYES: _____

NAYS: _____

ABSENT: _____

APPROVED this ____ day of _____ 2021.

Robert J. Lovero, Mayor

ATTEST:

Margaret Paul, City Clerk

Published by me in pamphlet form this ____ day of _____, 2021.

Margaret Paul, City Clerk

**CITY OF BERWYN
LEGAL NOTICE/NOTICE OF PUBLIC HEARING**

Notice is hereby given to all interested persons that the City Council of the City of Berwyn will hold a public hearing on Tuesday, the 22nd day of June, 2021, in the City of Berwyn Council Chambers on the second floor, located at 6700 West 26th Street, Berwyn, Illinois, at the hour of 7:00 P.M. or as soon thereafter as the business of the City Council permits, to consider the following:

The request of the City of Berwyn (the "Applicant") for certain amendments to the text of the Zoning Code of the City of Berwyn ("Zoning Code") relative to permitted interior side yard setbacks in the C-1 Neighborhood Mixed-Use Zoning Districts when a residential use is adjacent to a residential district or a residential use.

The Applicant proposes the following amendments:

- Amendment of Table 1246.04-A. (C-1 District Requirements) within Section 1246.04 (C-1 Neighborhood Mixed-Use District Requirements), which specifies minimum interior side yard setbacks within the C-1 District, to change the required interior side yard setback from the current ten (10) feet when a residential or non-residential use is adjacent to a residential district or residential use, to three (3) feet when a residential use is adjacent to a residential district or a residential use.

The amendments to the text of the Zoning Code may be considered for approval by the City Council following a public hearing based on consideration of a balance of the standards set forth for such amendments in Section 1252.03.E.3. of the Zoning Code. A full copy of the proposed Text Amendment is available upon request from Margaret Paul, City Clerk of the City of Berwyn.

During the Public Hearing the City Council will hear testimony from and consider any evidence presented by persons interested to speak on this matter. In addition, objections and other comments, if any, relating to the proposed Text Amendment request may be submitted to City Clerk Margaret Paul at mpaui@ci.berwyn.il.us, 6700 West 26th Street, Berwyn, Illinois, prior to 4:00 P.M. the day of the Public Hearing.

The Public Hearing may be continued from time to time without further notice, except as otherwise required under the Illinois Open Meetings Act.

Dated this 4th day of June, 2021

By Order of the City of Berwyn City Council
Margaret Paul, City Clerk
6/5/2021 #1127411

STATE OF ILLINOIS)
) SS
COUNTY OF COOK)

CLERK'S CERTIFICATE

I, Margaret Paul, Clerk of the City of Berwyn, in the County of Cook, State of Illinois, do hereby certify that the attached and foregoing is a true and correct copy of that certain Ordinance now on file in my Office, entitled:

ORDINANCE NO. _____

AN ORDINANCE AMENDING TABLE 1246.04-A. (C-1 DISTRICT REQUIREMENTS) WITHIN SECTION 1246.04 (C-1 NEIGHBORHOOD MIXED-USE DISTRICT REQUIREMENTS) OF TITLE 4 (ZONING) OF PART TWELVE (PLANNING AND ZONING) OF THE CODIFIED ORDINANCES OF BERWYN RELATIVE TO INTERIOR SIDE YARD SETBACKS IN THE C-1 NEIGHBORHOOD MIXED-USE ZONING DISTRICT

which Ordinance was passed by the City Council of the City of Berwyn at a Regular City Council Meeting on the ___ day of _____, 2021, at which meeting a quorum was present, and approved by the Mayor of the City of Berwyn on the ___ day of _____, 2021.

I further certify that the vote on the question of the passage of said Ordinance by the City Council of the City of Berwyn was taken by Ayes and Nays and recorded in the minutes of the City Council of the City of Berwyn, and that the result of said vote was as follows, to-wit:

AYES:

NAYS:

ABSENT:

I do further certify that the original Ordinance, of which the foregoing is a true copy, is entrusted to my care for safekeeping, and that I am the lawful keeper of the same.

IN WITNESS WHEREOF, I have hereunto set my hand and affixed the seal of the City of Berwyn, this ___ day of _____, 2021.

City Clerk

[SEAL]

ORDINANCE NO. _____

AN ORDINANCE AMENDING TABLE 1246.04-A. (C-1 DISTRICT REQUIREMENTS) WITHIN SECTION 1246.04 (C-1 NEIGHBORHOOD MIXED-USE DISTRICT REQUIREMENTS) OF TITLE 4 (ZONING) OF PART TWELVE (PLANNING AND ZONING) OF THE CODIFIED ORDINANCES OF BERWYN RELATIVE TO INTERIOR SIDE YARD SETBACKS IN THE C-1 NEIGHBORHOOD MIXED-USE ZONING DISTRICT

WHEREAS, the City of Berwyn (the “City”) is a home rule unit of local government as is provided by Article VII, Section 6 of the Illinois Constitution of 1970 and, as such, may exercise various powers and perform numerous functions pertaining to its government and affairs in any manner not otherwise prohibited by law; and

WHEREAS, the City has proposed an amendment (the “Application”) to the text of Table 1246.04-A. (C-1 District Requirements) within Section 1246.04 (C-1 Neighborhood Mixed-Use District Requirements) of Title 4 (Zoning) of Part Twelve (Planning and Zoning) of the Codified Ordinances of Berwyn (the “Zoning Code”) relative to permitted interior side yard setbacks in the C-1 Neighborhood Mixed-Use Zoning Districts when a residential use is adjacent to a residential district or a residential use (the “Proposed Text Amendment”); and

WHEREAS, the Application has been processed in accordance with the Zoning Code, as amended, and has been referred to the City Council of the City (“City Council”) for a public hearing and consideration; and

WHEREAS, on _____, 2021, the City Council held a public hearing on the Application pursuant to notice thereof given in the manner required by law; and

WHEREAS, the City Council of the City, having duly considered all of the testimony, evidence, materials, facts and circumstances affecting the Application, find that the Application satisfies the standards set forth in Section 1252.03(E)(3) of the Zoning Code relating to Zoning Code text amendments.

WHEREAS, pursuant to the authority granted under Division 13 of the Illinois Municipal Code (65 ILCS 5/11-13-1 et seq.), and its home rule powers and authority, pursuant to Article VII, Section 6 of the Illinois Constitution of 1970, the City Council of the City approve the Proposed Text Amendment to the Zoning Code set forth below, and find the adoption of the Proposed Text Amendment to be in the best interests of the City.

NOW, THEREFORE, BE IT ORDAINED, by the City Council of the City of Berwyn, Cook County and State of Illinois, as follows:

SECTION 1: Incorporation. Each whereas paragraph set forth above is incorporated by reference into this Section 1.

SECTION 2: Text Amendment Approved. Line F. of Table 1246.04-A. (C-1 District Requirements) within Section 1246.04 (C-1 Neighborhood Mixed-Use District Requirements), which

specifies minimum interior side yard setbacks within the C-1 District, is amended to read in its entirety as follows:

Minimum Interior Side Setback	0 ft; 10 ft for non-residential uses if residential district or residential use is adjacent or if residential use; 3 ft. for residential uses if residential district or residential use is adjacent
-------------------------------	---

SECTION 3: No Other Changes. Except as to the Zoning Code Text Amendment set forth above in this Ordinance, all Chapters and Sections of the Codified Ordinances of Berwyn, as amended, shall remain in full force and effect.

SECTION 4: Severability and Repeal of Inconsistent Ordinances. Each section, paragraph, clause and provision of this Ordinance is separable, and if any section, paragraph, clause or provision of this Ordinance shall be held unconstitutional or invalid for any reason, the unconstitutionality or invalidity of such section, paragraph, clause or provision shall not affect the remainder of this Ordinance, nor any part thereof, other than that part affected by such decision. All ordinances, resolutions or orders, or parts thereof, in conflict with the provisions of this Ordinance are to the extent of such conflict hereby repealed.

SECTION 5: Effective Date. This Ordinance shall be in full force and effect from and after its passage, approval, and publication in pamphlet form in the manner provided by law.

PASSED this ____ day of _____ 2021.

AYES: _____

NAYS: _____

ABSENT: _____

APPROVED this ____ day of _____ 2021.

Robert J. Lovero, Mayor

ATTEST:

Margaret Paul, City Clerk

Published by me in pamphlet form this ____ day of _____, 2021.

Margaret Paul, City Clerk

**CITY OF BERWYN
LEGAL NOTICE/NOTICE OF PUBLIC HEARING**

Notice is hereby given to all interested persons that the City Council of the City of Berwyn will hold a public hearing on Tuesday, the 22nd day of June, 2021, in the City of Berwyn Council Chambers on the second floor, located at 6700 West 26th Street, Berwyn, Illinois, at the hour of 7:00 P.M. or as soon thereafter as the business of the City Council permits, to consider the following:

The request of the City of Berwyn (the "Applicant") for certain amendments to the text of the Zoning Code of the City of Berwyn ("Zoning Code") relative to permitted interior side yard setbacks in the C-1 Neighborhood Mixed-Use Zoning Districts when a residential use is adjacent to a residential district or a residential use.

The Applicant proposes the following amendments:

- Amendment of Table 1246.04-A. (C-1 District Requirements) within Section 1246.04 (C-1 Neighborhood Mixed-Use District Requirements), which specifies minimum interior side yard setbacks within the C-1 District, to change the required interior side yard setback from the current ten (10) feet when a residential or non-residential use is adjacent to a residential district or residential use, to three (3) feet when a residential use is adjacent to a residential district or a residential use.

The amendments to the text of the Zoning Code may be considered for approval by the City Council following a public hearing based on consideration of a balance of the standards set forth for such amendments in Section 1252.03.E.3. of the Zoning Code. A full copy of the proposed Text Amendment is available upon request from Margaret Paul, City Clerk of the City of Berwyn.

During the Public Hearing the City Council will hear testimony from and consider any evidence presented by persons interested to speak on this matter. In addition, objections and other comments, if any, relating to the proposed Text Amendment request may be submitted to City Clerk Margaret Paul at mpaui@ci.berwyn.il.us, 6700 West 26th Street, Berwyn, Illinois, prior to 4:00 P.M. the day of the Public Hearing.

The Public Hearing may be continued from time to time without further notice, except as otherwise required under the Illinois Open Meetings Act.

Dated this 4th day of June, 2021

By Order of the City of Berwyn City Council
Margaret Paul, City Clerk
6/5/2021 #1127411

STATE OF ILLINOIS)
) SS
COUNTY OF COOK)

CLERK'S CERTIFICATE

I, Margaret Paul, Clerk of the City of Berwyn, in the County of Cook, State of Illinois, do hereby certify that the attached and foregoing is a true and correct copy of that certain Ordinance now on file in my Office, entitled:

ORDINANCE NO. _____

AN ORDINANCE AMENDING TABLE 1246.04-A. (C-1 DISTRICT REQUIREMENTS) WITHIN SECTION 1246.04 (C-1 NEIGHBORHOOD MIXED-USE DISTRICT REQUIREMENTS) OF TITLE 4 (ZONING) OF PART TWELVE (PLANNING AND ZONING) OF THE CODIFIED ORDINANCES OF BERWYN RELATIVE TO INTERIOR SIDE YARD SETBACKS IN THE C-1 NEIGHBORHOOD MIXED-USE ZONING DISTRICT

which Ordinance was passed by the City Council of the City of Berwyn at a Regular City Council Meeting on the __ day of _____, 2021, at which meeting a quorum was present, and approved by the Mayor of the City of Berwyn on the __ day of _____, 2021.

I further certify that the vote on the question of the passage of said Ordinance by the City Council of the City of Berwyn was taken by Ayes and Nays and recorded in the minutes of the City Council of the City of Berwyn, and that the result of said vote was as follows, to-wit:

AYES:

NAYS:

ABSENT:

I do further certify that the original Ordinance, of which the foregoing is a true copy, is entrusted to my care for safekeeping, and that I am the lawful keeper of the same.

IN WITNESS WHEREOF, I have hereunto set my hand and affixed the seal of the City of Berwyn, this __ day of _____, 2021.

City Clerk

[SEAL]

The City of Berwyn



Robert J. Lovero
Mayor

F-1

A Century of Progress with Pride

July 13, 2021

Members of City Council

Re: **Resignation and Appointment of a member of the Berwyn Library Board**

Council Members:

There is a vacancy in the due to the recent resignation of Erika Corona Owens from the Berwyn Library Board. I am seeking to appoint Antoine Evans as the member to the Berwyn Library Board to fill the remaining term ending 11/10/2023.

I would ask that City Council concur in my recommendation of Antoine Evans and approve the appointment.

Sincerely,

Robert J. Lovero
Mayor



EV

ANTOINE EVANS

OBJECTIVE

Build upon years of managerial experience in the hospitality industry while also seeking new challenges that lead to opportunities to create positive development and desirable outcomes in my career and my community.

SKILLS

Proficient in Excel &
PowerPoint
Host Zoom Meetings
Direct Conference Calls
Analyze P&Ls
Create Projections
Facilitate Training Classes

EXPERIENCE

Solano De Carrier Management Company Norridge, Il.
Operations Consultant 09/1993 - Present

Responsible for daily operations focus on internal/external customers, sales, and profit for multiple locations. Duties include shoulder-to-shoulder development of general managers to direct them and their teams to operate clean, sufficiently staffed, and profitable restaurants consisting of over 300 employees.

EDUCATION

Austin College & Career Academy Chicago, Il.
Diploma 1991-1995

Triton Community College Melrose Park, Il.
Business 1996 – 1997

VOLUNTEER EXPERIENCE OR LEADERSHIP

Future Founders Program: traveled inner city schools and providing business insights to young aspiring entrepreneurs.

Volunteered at annual Rock The House fundraiser events, raising money for Ronald McDonald house Charity.

BERWYN, IL. 60402



EMAIL

TELEPHONE

ADDRESS

The City of Berwyn

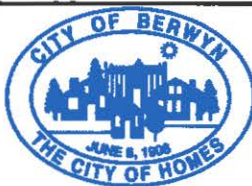

**Alicia Ruiz
6th Ward Alderman**

A Century of Progress with Pride

6700 West 26th Street Berwyn, Illinois 60402-0701 Telephone: (708) 788-2660 Fax: (708) 788-2675
www.berwyn-il.gov

I - 1

July 8, 2021

Mayor Lovero
City Council Members

Re: 4 Day Water Outage

Dear Council Members:

On June 27, at 7:30am I was alerted by residents who reside on both 1900 & 2100 Ridgeland that they were without water. I immediately contacted Public Works Director who acted promptly to the call and had his team on the scene. Although, Public Works was able to secure water for 1900 Ridgeland, the residents of 2100 Ridgeland (roughly 36 families) remained without water for a total of 4 days.

On Day 2, with no remediation in sight, I immediately acted to secure drinking water and a bathing facility for the families in my ward. This was done by soliciting donations from Costco and the PAV YMCA as well as corraling community residents to assist me in reaching every family affected by this unfortunate circumstance. While delivering resources to 6th ward residents it was discovered that 5th ward residents were affected as well. Alderman Pabon immediately worked to communicate with his residents.

On Day 3, as Public Works worked diligently to identify the problem without success, I requested portable potties and access to water via hydrants so that residents may have water for household needs. There were many families that did not have an option to relocate until the matter was resolved.

On Day 4, I secured a meal for dinner, water, and wipes for 6th ward families by soliciting donations from Pete Fe, Paisian and 6th ward residents. I did this to express my gratitude for the patience and understanding during a very difficult situation for all parties. Alderman Pabon pursued the same for his residents from additional local businesses (World's Largest Laundromat, Lunges and Lattes) and homemade meals from residents. Roughly, at 8:30pm the water was restored, and all residents were with adequate water pressure and flow on both 1900 and 2100 Ridgeland.

All of this would not have been possible without the actions of the Alderpersons serving their residents and the compassion and generosity from community organizations, businesses, and residents who showed up in what I considered "A State of Emergency." I am sure you would agree with me that it is inhuman and unhealthy for any person to be without water.

I would like to add that there was a full spectrum of familial statuses affected by this during some of the hottest days potentially endangering persons with medical or limited capabilities. A high risk, I believe, that our city must have policies and protocols in place to reduce our legal risk and to act in good faith.

Finally, I believe situations occur to test our strength and allow us the opportunity to improve. This is another example of the need for improvement. Therefore, I request that the Public Works, Parking, Trees, Traffic, Streets & Sewers Committee review the chain of events and devise A State of Emergency plan for future occurrences that hinder the quality of life of our residents.

Respectfully,

A handwritten signature in black ink, appearing to read "Alicia M. King". The signature is written in a cursive style with a large, sweeping initial 'A'.

6th Ward Alderman

The City of Berwyn



Alicia Ruiz
6th Ward Alderman

A Century of Progress with Pride

6700 West 26th Street Berwyn, Illinois 60402-0701 Telephone: (708) 788-2660 Fax: (708) 788-2675
www.berwyn-il.gov

I-2

July 9, 2021

Mayor Lovero
Council Members
City of Berwyn

Mayor Lovero & Council Members:

Re: Implementation of Diversity Commission

Some of you may recall, last year we deferred codifying a Diversity Commission due to a request made by a former Alderperson. Unfortunately, due to a chain of events, the plan was delayed longer than necessary.

Since the deferment, it has been proven that multiple functionalities of our city are in dire need of improvement and must have a collaborative (residents and elected officials) vision for Diversity, Equity and Inclusion. Therefore, I recommend we codify the Diversity Commission which will perform as a liaison between our residents and city council members. The commission will provide recommendations to City Council member to ensure that diversity, equity and inclusion is considered and implemented in our policies and procedures.

Once codified, I propose the next steps of the commission is to identify a pool of members for vacant seats and outline a 1-2 year strategy to be presented to City Council for approval.

Kind Regards,

A handwritten signature in black ink that reads "Alicia M. Ruiz". The signature is written in a cursive style.

Alderman Alicia M. Ruiz

Commission Members

Jesus Ramirez

Nenci Rodriguez

Dritan Cara

Vacant

Vacant

Alderman Alicia M. Ruiz - City Council Liaison



I-3

CITY OF BERWYN EVENT APPLICATION



Handwritten notes: 6/22/21, 11:53, and a signature.

Please provide information about your planned event:

DISPOSITION

Date of Event: September 18th, 2021 Time: Start 11:00 AM End 11:00 PM

Type: Block Party [] Parade [] Open Air Event [x] Use of Public Way []

Allowed event times: Block Parties 8AM to 9PM, All Other Events 8AM to 11PM

Description of Event: Annual Client Appreciation - RE/MAX Summer Fest

Location of Event: 6420 W Cermak Rd (RE/MAX Partners) Vacin Fairway

(Please print)

Name of Applicant: Luis Ortiz

Address: 6420 W. Cermak Rd Berwyn, IL 60402 Daytime Phone: _____

E-mail Address: _____ Alt. Phone: _____

Do you plan to use: Live or Recorded Music [x], Sound Equip. / Amplifiers [x], Bounce Houses or Inflatables [x], Food Vendors [x], Commercial Food Prep. Equipment [], Crafter / Vendors [x], Alcohol Sales [x], Portable Toilets and Sanitation [x]

Will you require any of the following City services? Yes [] No []

* Please contact the Police Dept. for fee schedule if requesting Police Detail or Security. ** These City services supplied only if available on the day of the event and subject to personnel availability. Street Closure [x], Rolling Street Closure [], Alley Closure [x], Parade Route Closure [], Barricades [x], *Police Detail/ Security [], Traffic Control [], **Berwyn Public Library Book Peddler (Bike) [], **Fire Truck [x], **McGruff [], **K-9 Unit [], **Police Explorers Unit [x]

City Council Approval IS REQUIRED for your event. (City Council meets the 2nd & 4th Tuesday of every month)
• Submit this application to the Clerk's Office 8 weeks prior to the event date.
• A Certificate of Insurance is required for Parades, Outdoor Events, Use of Public Way, as well as for all food and beverage sales.
• A Food License is required from the Berwyn Public Health Department for ALL food sales.
• A City of Berwyn Temporary Liquor License is required for ALL alcoholic beverage sales.
• A route map must be submitted with this application for all parades / demonstrations.
• USE OF PUBLIC WAY: Provide a list of intersections/corner locations and all dates being requested for use of public way. Location and Date availability is subject to approval. Use of public way is limited to one group per day, one group per location, and on a First Come—First Serve basis.
• The City reserves the right to regulate, restrict and limit use of the public way at all times.



The City of Berwyn



**Joseph Carmichael
8th Ward Alderman**

A Century of Progress with Pride

6700 West 26th Street Berwyn, Illinois 60402-0701

I-4

To Whom it May Concern:

American Legion is requesting permission to host their annual picnic. They are requesting the cul-de-sac immediately outside Commodore Barry on Clinton be blocked off at Roosevelt. The event is free to all residents and they encourage all to attend.

Thank you,

Joe Carmichael
8th Ward Alderman



CITY OF BERWYN EVENT APPLICATION

Please provide information about your planned event.

Date of Event 8/7, 2021 Time Start 12:00 PM End 4:00 PM

Type Block Party Parade Open Air Event Use of Public Way

Description of Event American Legion Annual Picnic

Location of Event: Commodore Barry 6919 Roosevelt Rd

APPLICANT'S USE ONLY
DATE RECEIVED
BY
DATE APPROVED
BY

Name of Applicant Joe GARMICHAEL

Address 1000 ... Daytime Phone.

E-mail Address: joegarmichael1874@gmail.com Alt. Phone:

Do you plan to use (Please mark all that apply)

Live or Recorded Music <input type="checkbox"/>	Sound Equip / Amplifiers <input type="checkbox"/>	Bounce Houses or Inflatables <input type="checkbox"/>
	Food Vendors <input type="checkbox"/>	Commercial Food Prep. Equipment <input type="checkbox"/>
Crafter / Vendors <input type="checkbox"/>	Alcohol Sales <input type="checkbox"/>	Portable Toilets and Sanitation <input type="checkbox"/>

Will you require any of the following City services? Yes No

* Please contact the Police Dept for fee schedule if requesting Police Detail or Security

Street Closure <input checked="" type="checkbox"/>	Rolling Street Closure <input type="checkbox"/>	Alley Closure <input type="checkbox"/>	Parade Route Closure <input type="checkbox"/>
Barricades <input checked="" type="checkbox"/>	*Police Detail/ Security <input type="checkbox"/>	Traffic Control <input type="checkbox"/>	**Berwyn Public Library Book Peddler (Bike) <input type="checkbox"/>
**Fire Truck <input type="checkbox"/>	**McGruff <input type="checkbox"/>	**X-9 Unit <input type="checkbox"/>	**Police Explorers Unit <input type="checkbox"/>

** These City services supplied only if available on the day of the event and subject to personnel availability

City Council Approval IS REQUIRED for your event. (City Council meets the 2nd & 4th Tuesday of every month)

- Submit this application to the Clerk's Office **8 weeks** prior to the event date.
- A Certificate of Insurance is required for Parades, Outdoor Events, Use of Public Way, as well as for all food and beverage sales.
- A Food License is required from the Berwyn Public Health Department for ALL food sales.
- A City of Berwyn Temporary Liquor License is required for ALL alcoholic beverage sales.
- A route map must be submitted with this application for all parades / demonstrations
- **USE OF PUBLIC WAY:** Provide a list of intersections/corner locations and all dates being requested for use of public way. Location and Date availability is subject to approval. Use of public way is limited to one group per day, one group per location, and on a First Come--First Serve basis.
- **The City reserves the right to regulate, restrict and limit use of the public way at all times.**

The City of Berwyn
6700 W. 26th St.
708-788-2660



Scott Lennon
1st Ward Alderman

A Century of Progress with Pride

I-5

July 7, 2021

Mayor Robert J. Lovero
Members of the City Council
6700 W. 26th Street
Berwyn, IL 60402

RE: Halfway to St. Patrick's Day Event/The James Joyce Irish Pub

Dear Mayor and Members of the City Council:

I am asking for permission to allow the James Joyce Irish Pub located at 7138 Windsor Ave., Berwyn, to host their 5th annual Halfway to St. Patrick's Day event. The event will be held on Saturday, September 25, 2021 from 3:00 p.m. until 11:00 p.m. There will be a tent erected in front of the pub and street closure from Maple Ave. to Harlem. Irish Dancers, Folk Singers and the Band of Brothers Pipes and Drums will be performing throughout the day. Food will also be available. The event will have a traditional Irish theme.

The James Joyce is hosting the event along with the Band of Brothers Pipes and Drums. The Band of Brothers Pipes and Drums was established in 2002. Members travel and play to many of their Brothers and Sisters line of duty death funerals, a nearly 200-year fire service tradition. The band is comprised of 40 members representing 22 fire departments from across the Chicagoland and Northwest Indiana regions. I am proud that two retired Berwyn Firefighters are currently playing with this band. This event enhances fundraising efforts for the band to continue this tradition.

This event would require closure of Windsor Avenue from Maple Avenue to Harlem Avenue the day of the event. Tents will be placed in front of the Joyce for the event and will need to be erected in the morning. Signage will need to be placed the day prior, Saturday, September 25th, for no parking from 6:00 a.m. to Sunday, September 26th to 9:00 a.m. I am also asking for 2 Auxiliary Police Officers to be at the event for the time stated above. The event was held without incident in previous years, and it is their hope to continue this event each year. Public Works will need to provide barricades to close the street at Harlem and Maple Avenues for the event the day prior to the event, provide porta potties, additional cardboard garbage containers. They are requesting the Fire Department to fill the barrels used for the tent with water.

The James Joyce will notify the residents on the block of the street closure and the timeline of the event.

It is my request that permission be granted for the James Joyce Irish Pub to host the event as stated above.

Sincerely,

Scott Lennon
Alderman, 1st Ward
City of Berwyn

CC: Berwyn Police Chief - Michael Cimaglia
Berwyn Public Works Director - Robert Schiller
Berwyn Fire Chief - Tom Hayes



CITY OF BERWYN EVENT APPLICATION



Please provide information about your planned event:

Date of Event: 9-25, 2021 Time: Start 3:00pm End 11:00 p.m.

Allowed Event Times
Block Parties
8AM to 9PM
All Other Events
8AM to 11PM

Type: Block Party [X] Parade [] Open Air Event [] Use of Public Way []

Description of Event: 5th Annual Half-way to St. Patrick's Day

Location of Event: 7138 Windsor Ave - Close Street between Harkness + Maple

(Please print)

Name of Applicant: The James Joyce Irish Pub - Brendan White

Address: 7138 Windsor Ave Daytime Phone: 708-795-1100

E-mail Address: brendano@thejamesjoycepub.com Alt. Phone:

Do you plan to use: Live or Recorded Music [X], Sound Equip. / Amplifiers [X], Bounce Houses or Inflatables [], Food Vendors [X], Commercial Food Prep. Equipment [], Crafter / Vendors [], Alcohol Sales [X], Portable Toilets and Sanitation [X]

Will you require any of the following City services? Yes [] No [X]

* Please contact the Police Dept. for fee schedule if requesting Police Detail or Security.

Street Closure [X], Rolling Street Closure [], Alley Closure [], Parade Route Closure [], Barricades [X], *Police Detail/Security [X], Traffic Control [], **Berwyn Public Library Book Peddler (Bike) [], **Fire Truck [], **McGruff [], **K-9 Unit [], **Police Explorers Unit []

** These City services supplied only if available on the day of the event and subject to personnel availability

- City Council Approval IS REQUIRED for your event. (City Council meets the 2nd & 4th Tuesday of every month)
• Submit this application to the Clerk's Office 8 weeks prior to the event date.
• A Certificate of Insurance is required for Parades, Outdoor Events, Use of Public Way, as well as for all food and beverage sales.
• A Food License is required from the Berwyn Public Health Department for ALL food sales.
• A City of Berwyn Temporary Liquor License is required for ALL alcoholic beverage sales.
• A route map must be submitted with this application for all parades / demonstrations.
• USE OF PUBLIC WAY: Provide a list of intersections/corner locations and all dates being requested for use of public way. Location and Date availability is subject to approval. Use of public way is limited to one group per day, one group per location, and on a First Come—First Serve basis.
• The City reserves the right to regulate, restrict and limit use of the public way at all times.

The City of Berwyn



Mary Beth Arenella
7th Ward Alderman

A Century of Progress with Pride

I-6

To: Mayor Robert J. Lovero
City Council Members

From: Mary Beth Arenella
7th Ward Alderman

Date: 8th July 2021

Re: 2200 Block of Grove Ave. Front Yard Sale

Please be advised that the 2200 Block of Grove Avenue, has requested & scheduled their Front Yard Sale for August 28, 2021 and August 29, 2021. The sale will be between 9:00am until 5:00pm on both days. They will be responsible for cleaning up the block at the end of each day. This is another method for the neighbors to jointly do something on their block. In the past, they have been able to draw a lot of people to the sale. Additionally, they will not require any additional services from the city.

Recommendation: Please join me in approving this request for the residents of the 2200 block of Grove Avenue. I am asking to override Ordinance 823.02 (D) prohibiting front yard sales for this one instance.

Respectfully,
Mary Beth Arenella
7th Ward Alderman



CITY OF BERWYN EVENT APPLICATION



Please provide information about your planned event:

Date of Event: Aug 28th + 29th 2021 Time: Start 10am End 5pm

Allowed Event Times:
Block Parties
8AM to 9PM
All Other Events
8AM to 11PM

Type: Block Party Parade Open Air Event Use of Public Way

Description of Event: Block Sale - Front Yard Sales

Location of Event: 7200 Block of Grove Ave

Please print

Name of Applicant: Amber Dawn

Address: _____ Daytime Phone: _____

E-mail Address: _____ Alt. Phone: _____

Do you plan to use: (Please mark all that apply)

Live or Recorded Music <input type="checkbox"/>	Sound Equip. / Amplifiers <input type="checkbox"/>	Bounce Houses or Inflatables <input type="checkbox"/>
	Food Vendors <input type="checkbox"/>	Commercial Food Prep. Equipment <input type="checkbox"/>
Crafter / Vendors <input type="checkbox"/>	Alcohol Sales <input type="checkbox"/>	Portable Toilets and Sanitation <input type="checkbox"/>

Will you require any of the following City services? Yes No

* Please contact the Police Dept. for fee schedule if requesting Police Detail or Security.

** These City services supplied only if available on the day of the event and subject to personnel availability

Street Closure <input type="checkbox"/>	Rolling Street Closure <input type="checkbox"/>	Alley Closure <input type="checkbox"/>	Parade Route Closure <input type="checkbox"/>
Barricades <input type="checkbox"/>	*Police Detail/ Security <input type="checkbox"/>	Traffic Control <input type="checkbox"/>	
**Fire Truck <input type="checkbox"/>	**McGruff <input type="checkbox"/>	**K-9 Unit <input type="checkbox"/>	**Police Explorers Unit <input type="checkbox"/>

City Council Approval IS REQUIRED for your event. (City Council meets the 2nd & 4th Tuesday of every month)

- Submit this application to the Clerk's Office **8 weeks** prior to the event date.
- A Certificate of Insurance is required for Parades, Outdoor Events, Use of Public Way, as well as for all food and beverage sales.
- A Food License is required from the Berwyn Public Health Department for ALL food sales.
- A City of Berwyn Temporary Liquor License is required for ALL alcoholic beverage sales.
- A route map must be submitted with this application for all parades / demonstrations.
- USE OF PUBLIC WAY: Provide a list of intersections/corner locations and all dates being requested for use of public way. Location and Date availability is subject to approval. Use of public way is limited to one group per day, one group per location, and on a First Come—First Serve basis.
- The City reserves the right to regulate, restrict and limit use of the public way at all times.

Block Garage-Yard Sale Petition to the City Council of Berwyn

We, the undersigned residents of the 2200 block of Grove Ave., Berwyn, IL, do hereby request permission to hold a block-wide garage-yard sale on the dates below.

Saturday and Sunday, August 28th & 29th

We, the undersigned, agree to the following:

1. Participating in this event counts as one of two annually permitted garage sales per address.
2. Sale hours are 9 am to 5 pm.
3. All trash must be placed in appropriate receptacles.
4. Each person participating must complete a block garage sale application.
5. Participants will abide by the terms of the city ordinance for garage sales with the EXCEPTION that we request permission to hold the sale in our front yards.

request permission to hold the sale in our front yards.

Redacted

House Number
2228
2221
2226
2223
2229
2240
2230
2217
2236
2245
2227
2249
2234
2222

Redacted

Margaret M. Paul

From: Margaret M. Paul
Sent: Friday, June 18, 2021 3:38 PM
To: 'Amberdawn70@gmail.com'
Cc: Sandra Anderson; '7thward@berwyn-il.gov'
Subject: Denial of Your Front Yard Sales Event Application
Attachments: Ch 823 Sec. 823. 02 D.pdf

Hello Amber: Sandy gave me your application for a front yard block long yard sale event scheduled for August 28 and August 29, 2021. I have to reject your event application for you and your neighbors. Yard sales taking place in the front yard are prohibited by Berwyn Ordinance. I have attached a copy of the ordinance.

I know that you and your neighbors have done this in 2019 and perhaps a few years prior. Ald. Avila would always write a communication asking the City Council to override the Ordinance for your specific event. I cannot individually override the city ordinances to grant your event application. Because it is specifically prohibited, your event cannot casually be placed on the City Council Consent Agenda.

Please contact Alderman Arenella to discuss this with her. Perhaps she will decide to override the Ordinance and place a communication on the next agenda on your behalf. I have included her on this email.

Margaret Paul, Berwyn City Clerk
(She, Her, Her's)
6700 W. 26th St.
Berwyn, IL 60402
708-749-6451

CHAPTER 823: CASUAL SALES

Section

- 823.01 License required
- 823.02 Conditions of license issuance
- 823.03 License fee
- 823.99 Penalty

Cross-reference:

Auctions and auctioneers, see Ch. 808

Home occupations, see § 802.15

§ 823.01 LICENSE REQUIRED.

No person shall engage in or conduct a garage, attic, basement or house sale from any residence, store, structure or lot in the city without first obtaining a license therefor from the City Collector.

(Ord. passed 11-29-1971)

§ 823.02 CONDITIONS OF LICENSE ISSUANCE.

No license required by § 823.01 shall be issued unless there is full compliance with the following terms and conditions.

(A) The applicant for the license shall be the owner of the premises where the sale is conducted, the agent of the owner or the executor or administrator of the owner's estate.

(B) The sale shall involve only personal property items owned by the applicant or members of his or her household.

(C) Only two sales shall be conducted by the same applicant or from the same premises during a 12-month period.

(D) No items for sale shall be located, and no sales activities shall be conducted, in the front yard area of any premises or on any public sidewalk, parkway area or other public property.

(E) All signs advertising the sale shall be located in the front yard area of the premises, and no sign, handbill or other advertising matter shall be located or posted in or upon any public parkway, building or other public property, with the exception of two signs, one for each corner parkway of the block on which the sale is occurring.

(1) The two permissible parkway signs shall be obtained from the City Collector's office. No other signs shall be permitted under this section.

(2) A deposit of \$10, per sign, by check or money order, shall be tendered to the Collector's office for the issuance of the signs. This deposit shall be returned upon the return of the signs. All signs shall be returned, undamaged, within five days after the sale or the deposit shall be forfeited.

(3) The parkway signs shall be displayed only during the hours of 7:00 a.m. and 7:00 p.m. and only on days of the sale. Failure to remove the signs shall result in a forfeiture of the deposit.

(F) The sale shall be limited to a consecutive period of not more than two days and shall be conducted only between the hours of 9:00 a.m. and 5:00 p.m.

(G) The sale shall be conducted without the use of outdoor loudspeakers or other amplification equipment.

(H) The sale shall be conducted in accordance with all other laws or ordinances of the city.

(I) The license shall be valid only for the particular sale and premises designated in the license and shall be posted in the front yard area so as to be easily seen by the public. The license is nontransferable.

(J) No license shall be issued, and no person or premises shall be eligible for the license, to conduct a sale of personal property items more than twice during a 12-month period.

(Ord. passed 11-29-1971; Ord. 06-37, passed 9-12-2006)

§ 823.03 LICENSE FEE.

There is no fee for the first license required by § 823.01. The second license issued within a 12-month period of the first license shall be \$20.

(Ord. passed 11-29-1971; Ord. 06-37, passed 9-12-2006)

§ 823.99 PENALTY.

See § 202.99 for general code penalty if no specific penalty is provided.

City of Berwyn
Department of Community Development

TO: Mayor Robert J. Lovero

FROM: Regina Mendicino, Director
Community Development Department

DATE: July 2, 2021

RE: Resolution to Adopt
2021 CDBG Annual Action Plan

J-1

Dear Mayor Lovero:

The attached Resolution and Copy of the City's 2021 Annual Action Plan (the "Plan") is submitted for the City Council's approval at the July 13, 2021 City Council Meeting. Prior to the City Council Meeting, there is a Public Hearing on the Plan during the Committee of the Whole Meeting.

The City continues to be successful in meeting its community development. The use of CDBG funds has been a tremendous asset in the City's efforts during these past few years.

The Community Development Department continues to investigate additional opportunities through such funding sources as the Cook County HOME Consortium, IHDA, and others. In addition, through its relationships with its public and private partners, the City continues to encourage owners to invest in their property's upkeep and care, create new jobs, and to address the social and economic distress the economic downturn created.

The Plan continues these efforts, and it is in the best interest of the City to receive CDBG funds for housing and related needs of low and moderate income persons. Should you have any questions regarding the Plan, please feel free to contact me.

Thank you for your prompt consideration of this Resolution.

Recommendation: Approve 2021 Annual Action Plan

Sincerely,



Regina Mendicino,
Director, Community Development

Regina Mendicino, Director, Community Development
6700 West 26th Street, Berwyn, IL 60402
(708) 795-6850 * (708) 749-9457

RESOLUTION NO. 2021 - _____

**A RESOLUTION APPROVING THE CITY OF BERWYN'S
ANNUAL ACTION PLAN FOR PROGRAM YEAR 2021
FOR COMMUNITY DEVELOPMENT BLOCK GRANT ("CDBG") FUNDS,
AND FOR AUTHORIZATION TO SUBMIT SAME TO THE UNITED STATES
DEPARTMENT OF HOUSING AND URBAN DEVELOPMENT ("HUD")**

WHEREAS, the City of Berwyn ("CITY") is a Home Rule Unit of Government pursuant to and as defined in Article 7 Section 6 (a) of the 1970 Illinois Constitution; and

WHEREAS, said Section of the Constitution authorizes a home rule unit of government to exercise any power, and perform any function, pertaining to its government affairs; and

WHEREAS, the 1970 Illinois Constitution, Article VII Section 10 and the Intergovernmental Cooperation Act provide authority for intergovernmental cooperation; and

WHEREAS, the City will receive an annual grant from HUD for CDBG Programs and the amount of said grant from October 1, 2021 to September 30, 2022 ("Program Year 2021") is expected to be \$1,338,353;

WHEREAS, the Mayor and the City Council have determined it is in the best interest of the City to receive CDBG funds from HUD for housing and related needs of low and moderate income persons; and

WHEREAS, the Community Development Department developed an Annual Action Plan for Program Year 2021 pursuant to HUD regulations and in accordance with a Citizen Participation Plan which meets HUD's requirements; and

WHEREAS, the City developed the 2021 Annual Action Plan to promote the development of a viable urban community, by providing decent housing and a suitable living environment and expanding economic opportunities, principally for low and moderate income persons, in conformance with the HUD Act of 1974, as amended, and the HUD regulations applicable thereto; and

WHEREAS, after due deliberation the City Council finds it would be in the best interest of the CITY to approve and submit the CITY's 2021 Annual Action Plan as drafted by the CITY's Department of Community Development.

NOW, THEREFORE, BE IT RESOLVED BY THE MAYOR AND THE CITY COUNCIL OF THE CITY OF BERWYN, COOK COUNTY, ILLINOIS, as follows:

SECTION 1:

That the Corporate Authorities of the CITY hereby approve the 2021 Annual Action Plan in substantially the same format as attached hereto and made a part hereof as Exhibit A, and said final draft is hereby authorized to be submitted to HUD.

SECTION 2:

That all proper publications having taken place, public hearings having been held and the 2021 Annual Action Plan having been available for public comment for over thirty days, all public comments and responses shall be included and submitted to HUD pursuant to Section 1 above.

SECTION 3:

That the Mayor and City Clerk are hereby directed and authorized to enter into on behalf of the CITY all contracts necessary and proper to fully implemented the 2021 Annual Action Plan, including, but not limited to, all contracts receiving or distributing any allocations of CDBG funds therein, all contracts under the Single Family Rehab Program, and as otherwise required to implement the 2021 Annual Action Plan.

SECTION 4:

That this Resolution shall be in full force and effect from and after its passage and approval according to the law.

PASSED this 13th day of July, 2021

Margaret M. Paul, City Clerk

Voting Aye:

Voting Nay:

Absent:

Deposited in my office this 13th day of July, 2021

Margaret M. Paul, City Clerk

APPROVED this 13th day of July, 2021

Robert J. Lovero, Mayor



BERWYN FIRE DEPARTMENT

July 13, 2021

J-2

To: Honorable Mayor Robert Lovero
Members of City Council
From: Fire Chief Thomas A. Hayes
Re: Recommendation to purchase a new Ladder Truck

The purpose of this communication is to recommend the purchase of a new E-One Ladder Truck. The price of the new truck is \$973,996.00, which will be financed over seven years at a 2.77% rate bringing the total cost to \$1,096,382.77. An annual payment of \$156,626.11 has been included in the Fire Department budget. Truck 904 is the primary ladder truck for the City of Berwyn. It is currently 17 ½ years old and is becoming increasingly more unreliable. The Berwyn Fire Department has done extensive research spanning more than two years and the Truck Committee has unanimously recommended the purchase of the E-One truck. A comparison sheet has been attached to this communication.

I am seeking approval to enter into a purchase agreement with HGACBuy, a nationwide, government procurement service. This contract has been awarded by virtue of a public competitive procurement process compliant with state statutes. This expenditure is included in the Fire Department budget.

Respectfully submitted,

A handwritten signature in black ink that reads "Thomas A. Hayes".

Thomas A. Hayes
Fire Chief



Ladder Truck Purchase

Background: The Berwyn Fire Department has identified the need to replace an aging ladder truck. Truck 904 is the most utilized fire truck in the City of Berwyn. Ideally, we would like to replace the truck after 15 years. However, the purchase has been delayed due to budget issues. The truck is currently 17 ½ years old and will be 19 years old at the time a new truck is ready for service. Therefore, it is important that we replace this truck now. We will stay on our vehicle replacement schedule and budget with a seven year loan.

Purchase Description: The cost of the truck is \$973,996.00. The truck will be purchased through the government procurement service, HGACBuy and will be financed through REV Financial Services. The terms are seven years at an interest rate of 2.77%. An annual payment of \$156,626.11 has been included in the Fire Department budget. This is the lowest priced truck that meets the Fire Department's specifications and needs. Total cost of the truck after financing will be \$1,096,382.77.

Competitive Bid: This contract has been awarded by virtue of a public competitive procurement process compliant with state statutes.

Market Research Overall Findings: The Fire Department's Truck committee has researched the top vendors for trucks that meet all of our residents' needs. The Berwyn Fire Department has several unique considerations when determining the right truck for Berwyn. First of all, our viaducts at East Avenue and Oak Park Avenue are posted at 11' 3" and the building where Truck 904 is stationed is also 11'3". Secondly, we must have a 100 foot aerial ladder. And, lastly, it is very difficult to maneuver many of the larger ladder trucks through our City's streets. These factors greatly limited which manufacturers qualified for our consideration during our research. For example, many manufacturers do not make a ladder truck that meets our height requirement on a single axle, one hundred foot aerial ladder truck.

Compatibility: This truck meets all requirements of the Berwyn Fire Department. The research committee and Fire Department mechanics believe this truck will meet our residents' needs for the next fifteen to twenty years.



June 3, 2021

RE – City of Berwyn, IL - Municipal Finance Quote

REV Financial Services is pleased to present the following \$0 Payment Down Finance Proposal described below:

PROPOSAL:

LESSEE:	City of Berwyn, IL						
PROPERTY:	E-One Low Travel Height Aerial (Cost = \$1,004,660 / \$973,996 if 100% prepaid within 30 days of order)						
EXPIRATION:	July 15, 2020						
INDEX:	INDEXED TO Like Term SWAP Rate – Rates subject to change						
FINANCE QUOTE:	Finance Amount	Rate	Payments	Factor	Pmts / Year	Term	Adv. / Arr.
\$0 Payments Down	\$ 973,996.00	2.68%	\$ 212,828.46	0.218510608	1	65 months	Arrears
\$0 Payments Down	\$ 973,996.00	2.71%	\$ 179,890.00	0.184692755	1	77 months	Arrears
\$0 Payments Down	\$ 973,996.00	2.77%	\$ 156,626.11	0.160807755	1	89 months	Arrears

FINANCING: This is a tax-exempt, municipal government lease purchase with the title to the property passing to Lessee. This is a net lease under which, all costs, including insurance, maintenance, and taxes, are paid by Lessee for the term of the lease. Rates assume municipal/bank qualified.

NOTES: This structure requires 100% Prepayment Option. Performance Bond is included in pricing. Please see page 2 for sample payment tables.

APPROVAL: This proposal, until credit approved, serves as a quotation, not a commitment by Lessor to provide credit or property. Lessor acceptance of this Proposal is subject to credit; collateral and essential use review and approval by Lessor. The interest rate quoted herein assumes that the interest component of the Payments is exempt from federal income tax. Lessor will provide a taxable financing proposal if it is determined that the financing will not qualify for tax-exempt interest rates. The financing contemplated by this proposal is subject to the execution and delivery of all appropriate documents (in form and substance satisfactory to Lessor), including without limitation, to the extent applicable, the Master Lease Agreement, any Schedule, financing statements, legal opinion or other documents or agreements reasonably required by Lessor. The quoted interest rate assumes the Lessee designates the Lease as "bank-qualified" pursuant to Section 265(b) of the Code.

Thank you for the opportunity to present this proposal. If you have any questions, please contact me at my number or e-mail address below.

Sincerely,

Todd Stevenson
 National Sales Manager
 (303) 254-6350
todd.stevenson@revgroup.com
www.REVgroup.com

Proposal Acceptance:

Options: 5 / 6 / 7 years (please circle)

Signed: _____

Name: _____

Title: _____

Date: _____



Example for Comparison

	<u>E-One</u>	<u>Pierce</u>
Vehicle height	10' 11"	11' 1"
Vehicle length	38' 10"	42' 9.25"
Stabilizer spread	11'	12'
Ladder reach	100'	100'
Ladder warranty	20 years	20 years
Rear axle	Single	Tandem
APR	2.77%	3.09%
Term	7 years	7 years
Annual payment	\$ 156,626.11	\$ 225,498.00
Total cost	\$ 1,096,382.77	\$ 1,578,486.00



Mayor
Robert J. Lovero

BERWYN POLICE DEPARTMENT
"Serving with Pride"



Chief of Police
Michael D. Cimaglia

J-3

06 July 2021

Honorable Mayor Robert J. Lovero and
Members of the Berwyn City Council
6700 W. 26th Street
Berwyn, Illinois 60402

RE: Request to promote one (1) Police Sergeant to the civil service rank of Lieutenant.

Ladies and Gentlemen,

I am respectfully requesting your approval to contact the Police and Fire Commission to promote one (1) Police Sergeant to the Civil Service Rank of Lieutenant from the current Fire and Police Commissioners Eligibility list. This request is being made to replace the vacancy that resulted from the following:

- The Total Temporary Disability of Lieutenant Michael Vokac effective on May 17, 2021.

This request is in accordance with the current Collective Bargaining Agreement.

Pending authorization, the actual date of promotion will be Wednesday July 14, 2021 at the Berwyn Police Department.

Please if you have any questions do not hesitate to contact me.

Thank you in Advance,

Michael D. Cimaglia
Chief of Police
Berwyn Police Department



Mayor
Robert J. Lovero

BERWYN POLICE DEPARTMENT
"Serving with Pride"



Chief of Police
Michael D. Cimaglia

J-4

06 July 2021

Honorable Mayor Robert J. Lovero and
Members of the Berwyn City Council
6700 W. 26th Street
Berwyn, Illinois 60402

RE: Request to promote one (1) Patrol Officer to the civil service rank of Sergeant.

Ladies and Gentlemen,

I am respectfully requesting your approval to contact the Police and Fire Commission to promote one (1) Patrol Officer to the Civil Service Rank of Sergeant from the current Fire and Police Commissioners eligibility list. This request is being made to replace the vacancy that resulted from the following:

- The Sergeant vacancy that has been created by the promotion of the Sergeant to the Civil Service Rank of Lieutenant.

This request is in accordance with the current Collective Bargaining Agreement.

Pending authorization, the actual date of promotion will be Wednesday July 14, 2021 at the Berwyn Police Department.

Please if you have any questions do not hesitate to contact me.

Thank you in Advance,

Michael D. Cimaglia
Chief of Police
Berwyn Police Department



Mayor
Robert J. Lovero

BERWYN POLICE DEPARTMENT

"Serving with Pride"



Chief of Police
Michael D. Cimaglia

J-5

06 July 2021

Honorable Mayor Robert J. Lovero and
Members of the Berwyn City Council
6700 W. 26th Street
Berwyn, Illinois 60402

RE: Request to promote one (1) Patrol Officer to the civil service rank of Sergeant.

Ladies and Gentlemen,

I am respectfully requesting your approval to contact the Police and Fire Commission to promote one (1) Patrol Officer to the Civil Service Rank of Sergeant from the current Fire and Police Commissioners Eligibility list. This request is being made to replace the vacancy that resulted from the following:

- The Total Temporary Disability of Sergeant Carl Gray effective on May 06, 2021.

This request is in accordance with the current Collective Bargaining Agreement.

Pending authorization, the actual date of promotion will be Wednesday July 14, 2021 at the Berwyn Police Department.

Please if you have any questions do not hesitate to contact me.

Thank you in Advance,

Michael D. Cimaglia
Chief of Police
Berwyn Police Department



Mayor
Robert J. Lovero

BERWYN POLICE DEPARTMENT

"Serving with Pride"



Chief of Police
Michael D. Cimaglia

J-6

06 July 2021

Honorable Mayor Robert J. Lovero and
Members of the Berwyn City Council
6700 W. 26th Street
Berwyn, Illinois 60402

RE: Request to hire Six (6) Probationary Police Officers from the Lateral Eligibility Pool

Ladies and Gentlemen,

I am respectfully requesting your approval to contact the Police and Fire Commission to hire six (6) Probationary Police Officers from the current Fire and Police Commissioners current Lateral Eligibility Pool of candidates. These requests are to replace the vacancies that have resulted from the following:

- The Retirement of Sergeant Carmelita Terry;
- The Resignation of Probationary Patrol Officer Jason Aguirre;
- The Total Temporary Disability of Lieutenant Michael Vokac;
- The Total Temporary Disability of Sergeant Carl Gray;
- The Resignation of Probationary Patrol Officer Nicole Ortega;
- The Resignation of Probationary Patrol Officer Carolina Ortega.

The hiring of six Probationary Police Officers satisfies the current contractual agreement between the City of Berwyn and the Illinois Municipal Police Association (IMPA).

Please if you have any questions do not hesitate to contact me.

Thank you in Advance,

Michael D. Cimaglia

Chief of Police

Berwyn Police Department



Mayor
Robert J. Lovero

BERWYN POLICE DEPARTMENT

"Serving with Pride"

J-7



Chief of Police
Michael D. Cimaglia

Mayor Robert J. Lovero and
Berwyn City Council
6700 W. 26th Street
Berwyn, Illinois 60402

06 July 2021

RE: Purchase of 5 New Vehicles

Ladies and Gentlemen,

The Berwyn Police Department is requesting authorization to purchase (5) vehicles. The vehicles will be used to replace old vehicles that need to be replaced. The vehicles to be replaced are as follows:

- The Berwyn Police Animal Control vehicle;
- The Berwyn Police prisoner transport vehicle;
- A Community Service Officer Vehicle;
- The Evidence Technician vehicle; and
- A Berwyn Police Patrol vehicle.

The purchase of the vehicles is covered under the Suburban Purchasing Cooperative sponsored by the Northwest Municipal Conference. These vehicles are budgeted for within the Police Budget, will be paid for out of the City of Berwyn's General Fund.

We are requesting your approval to waive the sealed bid process and accept the attached proposal from Currie Motors Frankfort Inc., at a total cost of \$172,513.00 for all five of the vehicles. Currie Motors is an approved vendor on the State Bid Contract List and is honoring the price for the 2021 contract.

Thank you for your consideration of this request.

If you have any questions please feel free to contact me.

Thank you in Advance,

Michael D. Cimaglia

Chief of Police

Berwyn Police Department

Prepared for: , City Of Berwyn

2021 Expedition 4dr 4x4 XL (U1G)

Price Level: 125



Client Proposal

Prepared by:
THOMAS SULLIVAN
Office: 815-464-9200
Quote ID: berwynexp
Date: 06/17/2021



Currie Commercial Center | 10125 W. Laraway, Frankfort, Illinois, 60423
Office: 815-464-9200

Prepared for:

City Of Berwyn

Prepared by: THOMAS SULLIVAN

06/17/2021



Currie Commercial Center | 10125 W. Laraway Frankfort Illinois | 60423

2021 Expedition 4dr 4x4 XL (U1G)

Price Level: 125 | Quote ID: berwynexp

Major Equipment

(Based on selected options, shown at right)

EcoBoost 3.5L V-6 DOHC w/gasoline direct injection 375hp

10 speed automatic w/OD

- * Auto stop-start feature
- * 4-wheel ABS
- * Electric parking brake
- * P 275/65R18 OWL AT T-rated tires
- * Advance Trac w/Roll Stability Control
- * Tinted glass
- * Bluetooth streaming audio
- * Rear child safety locks
- * Variable intermittent speed-sensitive wipers
- * Dual front airbags
- * Airbag occupancy sensor
- * Rear window defroster
- * Message Center
- * Reclining front bucket seats
- * Running boards
- * No Boundaries Roof Rack

Fuel Economy

Exterior: Agate Black Metallic

Interior: Ebony

- * Driver selectable mode
- * Brake assistance
- * Traction control
- * Battery with run down protection
- * Air conditioning
- * AM/FM/Satellite-prep with seek-scan, auxiliary audio input, external memory control
- * Daytime running
- * Dual power remote heated mirrors
- * 18 x 8.5 aluminum wheels
- * Driver and front passenger seat mounted side airbags
- * SecuriLock immobilizer
- * Tachometer
- * Underseat ducts
- * 40-20-40 folding rear split-bench
- * Audio control on steering wheel
- * Class IV hitch

As Configured Vehicle

MSRP

STANDARD VEHICLE PRICE	\$52,675.00
Engine: 3.5L EcoBoost V6	Included
Transmission: 10-Speed Automatic w/SelectShift	Included
GVWR: 7,450 lbs	Included
Cloth Front Captain's Chairs	Included
Monotone Paint Application	STD
122" Wheelbase	STD
Radio: AM/FM Stereo w/MP3 Capable	Included
50 States Emissions System	STD
Equipment Group 102A SSV Package	-\$2,080.00
ControlTrac w/3.73 Axle Ratio	Included
SYNC Communications & Entertainment System	Included
2-Speed Automatic 4WD	Included
Column Shifter	Included
Vinyl Floor Covering	Included
Vinyl 2nd Row Seating	Included
Skid Plates	Included
Center Console Delete	Included
USB Port Delete	Included

Prices and content availability as shown are subject to change and should be treated as estimates only. Actual base vehicle, package and option pricing may vary from this estimate because of special local pricing, availability or pricing adjustments not reflected in the dealer's computer system. See salesperson for the most current information.

Prepared for:

City Of Berwyn

Prepared by: THOMAS SULLIVAN

06/17/2021



Currie Commercial Center | 10125 W. Laraway Frankfort Illinois | 60423

2021 Expedition 4dr 4x4 XL (U1G)

Price Level: 125 | Quote ID: berwynexp

Major Equipment

City
17 mpg



Hwy
22 mpg

As Configured Vehicle

MSRP

Manual Telescoping Steering Wheel Delete Included

Push Button Keyless Start Delete Included

Agate Black Metallic N/C

Ebony N/C

Heavy-Duty Trailer Tow Package \$795.00

Wheels: 18" Machined-Face Aluminum w/536 Included

Tires: P275/65R18 AT OWL w/536 Included

Heavy-Duty Engine Radiator Included

Integrated Trailer Brake Controller Included

Black Platform Running Boards \$405.00

Reverse Sensing System \$110.00

SUBTOTAL \$51,905.00

Destination Charge \$1,695.00

TOTAL \$53,600.00

Prices and content availability as shown are subject to change and should be treated as estimates only. Actual base vehicle, package and option pricing may vary from this estimate because of special local pricing, availability or pricing adjustments not reflected in the dealer's computer system. See salesperson for the most current information.

Prepared for:
 City Of Berwyn
 Prepared by: THOMAS SULLIVAN
 06/17/2021



Currie Commercial Center | 10125 W. Laraway Frankfort Illinois | 60423

2021 Expedition 4dr 4x4 XL (U1G)

Price Level: 125 | Quote ID: berwynexp

As Configured Vehicle

Code	Description	MSRP
Base Vehicle		
U1G	Base Vehicle Price (U1G)	\$52,675.00
Powertrain		
99T	Engine: 3.5L EcoBoost V6 <i>Includes auto start-stop technology.</i>	Included
44U	Transmission: 10-Speed Automatic w/SelectShift	Included
STDGV	GVWR: 7,450 lbs	Included
Seats & Seat Trim		
L	Cloth Front Captain's Chairs <i>5-passenger seating. Includes 8-way power driver seat (power function for tilt and lumbar, manual recline). 4-way manual passenger seat (fore/aft, recline) and 2-way manually adjustable head restraints.</i>	Included
Other Options		
PAINT	Monotone Paint Application	STD
122WB	122" Wheelbase	STD
STDRD	Radio: AM/FM Stereo w/MP3 Capable <i>Includes speed-compensated volume and 6 speakers. Includes: - SYNC Communications & Entertainment System Includes enhanced voice recognition, 4.2" LCD screen in center stack, AppLink, 911 Assist and smart charging USB ports (first row - (1) A and (1) C. second row - (1) A and (1) C in the back side of the center floor console).</i>	Included
66R	Reverse Sensing System	\$110.00
Emissions		
425	50 States Emissions System	STD
Interior Color		
LH_01	Ebony	N/C
Exterior Color		
UM_03	Agate Black Metallic	N/C

Prices and content availability as shown are subject to change and should be treated as estimates only. Actual base vehicle, package and option pricing may vary from this estimate because of special local pricing, availability or pricing adjustments not reflected in the dealer's computer system. See salesperson for the most current information

Prepared for:
 City Of Berwyn
 Prepared by: THOMAS SULLIVAN
 06/17/2021



Currie Commercial Center | 10125 W. Laraway Frankfort Illinois | 60423

2021 Expedition 4dr 4x4 XL (U1G)

Price Level: 125 | Quote ID: berwynexp

As Configured Vehicle (cont'd)

Code	Description	MSRP
Fleet Options		
102A	Equipment Group 102A SSV Package <i>Includes:</i> - Engine: 3.5L EcoBoost V6 Includes auto start-stop technology. - Transmission: 10-Speed Automatic w/SelectShift - ControlTrac w/3.73 Axle Ratio Includes eLSD (Electronic Limited-Slip Differential). - 2-Speed Automatic 4WD Includes neutral towing capability. - GVWR: 7,450 lbs - Cloth Front Captain's Chairs 5-passenger seating. Includes 8-way power driver seat (power function for tilt and lumbar, manual recline), 4-way manual passenger seat (fore/aft, recline) and 2-way manually adjustable head restraints. - Radio: AM/FM Stereo w/MP3 Capable Includes speed-compensated volume and 6 speakers. - SYNC Communications & Entertainment System Includes enhanced voice recognition, 4.2" LCD screen in center stack, Applink, 911 Assist and smart charging USB ports (first row - (1) A and (1) C, second row - (1) A and (1) C in the back side of the center floor console). - Column Shifter - Vinyl Floor Covering - Vinyl 2nd Row Seating - Skid Plates Includes fuel tank underbody protection. - Center Console Delete Deletes armrest and covered media bin. - USB Port Delete Deletes second row smart charging USB port - one (1) A and one (1) C in the back side of the center floor console. - Manual Telescoping Steering Wheel Delete - Push Button Keyless Start Delete	-\$2,080.00
62E	ControlTrac w/3.73 Axle Ratio <i>Includes eLSD (Electronic Limited-Slip Differential).</i> <i>Includes:</i> - 2-Speed Automatic 4WD Includes neutral towing capability.	Included
NONTR2	Tires: P275/65R18 AT OWL w/536	Included
NONWL1	Wheels: 18" Machined-Face Aluminum w/536 <i>Includes magnetic painted pockets.</i>	Included
536	Heavy-Duty Trailer Tow Package <i>Includes:</i> - Wheels: 18" Machined-Face Aluminum w/536 Includes magnetic painted pockets. - Tires: P275/65R18 AT OWL w/536 - Heavy-Duty Engine Radiator - Integrated Trailer Breke Controller	\$795.00
18B	Black Platform Running Boards	\$405.00
Upfit Options		
P-01	Municipal Plates/Title-Shipped	\$203.00

Prices and content availability as shown are subject to change and should be treated as estimates only. Actual base vehicle, package and option pricing may vary from this estimate because of special local pricing, availability or pricing adjustments not reflected in the dealer's computer system. See salesperson for the most current information.

Prepared for:

City Of Berwyn

Prepared by: THOMAS SULLIVAN

06/17/2021



Currie Commercial Center | 10125 W. Laraway Frankfort Illinois | 60423

2021 Expedition 4dr 4x4 XL (U1G)

Price Level: 125 | Quote ID: berwynexp

As Configured Vehicle (cont'd)

Code	Description	MSRP
	<i>Title and Plates</i>	
ES-01111	Extended Warranty	\$2,290.00
	<i>Premiumcare</i>	
	<i>72 months</i>	
	<i>100000 miles</i>	
SUBTOTAL		\$54,398.00
Destination Charge		\$1,695.00
TOTAL		\$56,093.00

Prices and content availability as shown are subject to change and should be treated as estimates only. Actual base vehicle, package and option pricing may vary from this estimate because of special local pricing, availability or pricing adjustments not reflected in the dealer's computer system. See salesperson for the most current information.

Prepared for:

City Of Berwyn

Prepared by: THOMAS SULLIVAN

06/17/2021



Currie Commercial Center | 10125 W. Laraway Frankfort Illinois | 60423

2021 Expedition 4dr 4x4 XL (U1G)

Price Level: 125 | Quote ID: berwynexp

Pricing Summary - Single Vehicle

	MSRP
<i>Vehicle Pricing</i>	
Base Vehicle Price	\$52,675.00
Options	-\$770.00
Colors	\$0.00
Upfitting	\$2,493.00
Fleet Discount	\$0.00
Destination Charge	\$1,695.00
Subtotal	\$56,093.00
<i>Discount Adjustments</i>	
Discount Adjustments	-\$14,797.00
Total	\$41,296.00

Customer Signature

Acceptance Date

Prices and content availability as shown are subject to change and should be treated as estimates only. Actual base vehicle, package and option pricing may vary from this estimate because of special local pricing, availability or pricing adjustments not reflected in the dealer's computer system. See salesperson for the most current information.



**2021 Ford Escape S Front Wheel
Drive Contract# 165**



Currie Motors Fleet

"Nice People to Do Business With"

Order Cut 06/25/21

Contract # 165



Currie Motors Frankfort

SPC Contract Winner

2021 Ford Escape S Front Wheel Drive

Contract #165

Call Tom Sullivan (815) 464-9200

Standard Package: 20,885.00

Warranty: 3 Years 36, 000 miles Bumper to Bumper/ 5 Years 60,000 Power train

Free Delivery within 50 Miles
Climate Control
Advance Trac w/RSC
Power Windows Power Locks
Remote Keyless-Flip Key
Side View Mirrors-Power Glass
AM/FM/CD- SYNC
Variable Intermittent- Wipers
Rear Defroster
Electric Power Assist Steering
Cruise Control
Ford Pass Connect-4G LTE Wi-Fi
Personal Safety System
17" Steel Wheels
6-Way Manual Adjust Drivers Seat
Cloth Front Bucket Seats
60/40Split-Fold-Flat Rear Seats
Rotary Gear Shift Dial
Center Console w/Armrest

Front Carpeted Floor Mats
Anti-Lock Brakes-w/Post
Collision Braking
Frt/Rr Stabilizer Bar
Halogen Headlamps
Solar Tinted Glass
Battery Saver Feature
Message Center
Sun Visors w/Dual Mirrors
Tilt and Telescoping Wheel
1.5L Eco boost w/ Auto Start-Stop
Technology
8-Speed Automatic Transmission
Body Color Rear Spoiler
SecuriLock Passive Anti-Theft
Tire Pressure Monitoring System
3-Power Points
Tire Inflator/Sealant Kit
Rear View Camera

Contract # 165

Available Models

<input checked="" type="checkbox"/>	Escape SE All Wheel Drive	23,986.00
<input type="checkbox"/>	Escape SE FHEV All Wheel Drive	26,715.00

Options

<input type="checkbox"/>	Cargo Mat	86.00
<input type="checkbox"/>	Block Heater	33.00
<input checked="" type="checkbox"/>	Day Time Running Lights	42.00
<input checked="" type="checkbox"/>	Floor Liners	150.00
<input type="checkbox"/>	Privacy Glass	253.00
<input checked="" type="checkbox"/>	Reverse Sensing System	230.00
<input type="checkbox"/>	Easy Access Cargo Shade	128.00
<input type="checkbox"/>	Rustproofing (Sound Shield N/A)	295.00
<input type="checkbox"/>	17" Shadow Silver-painted Aluminum Wheels	559.00
<input type="checkbox"/>	Wheel Locking Lug Nuts	71.00
<input type="checkbox"/>	Cargo Management System-S model only	375.00
<input type="checkbox"/>	Remote Start	465.00
<input type="checkbox"/>	Splash Guards	197.00
<input type="checkbox"/>	CD Rom Shop Manual	295.00
<input type="checkbox"/>	3 year/100000 Mile Powertrain Care Warranty	1195.00
<input type="checkbox"/>	5 year/60,000 Mile Base Care Warranty	1395.00
<input type="checkbox"/>	Delivery >50 miles	165.00
<input checked="" type="checkbox"/>	Municipal Plates M____MP____ (Shipped)	203.00

Exterior Colors

<input type="checkbox"/>	Velocity Blue	N/C
<input type="checkbox"/>	Desert Gold Metallic	N/C
<input type="checkbox"/>	AntiMatter Blue	N/C
<input type="checkbox"/>	Bronze Fire	N/C
<input type="checkbox"/>	Iconic Silver	N/C
<input type="checkbox"/>	Carbonized Gray	N/C
<input checked="" type="checkbox"/>	Oxford White	N/C
<input type="checkbox"/>	Agate Black	N/C
<input type="checkbox"/>	Rapid Red- SE only	371.00
<input type="checkbox"/>	Star White-SE Only	559.00

Interior Colors

<input checked="" type="checkbox"/>	Ebony	N/C
<input type="checkbox"/>	Ebony/Sandstone – SE Only	N/C



Title Name CITY OF BERWYN
Title Address _____
Title City _____
Title Zip Code _____
Contact Name _____
Phone Number _____
Purchase Order Number _____
Fleet Identification Number _____
Tax Exempt Number _____
Total Dollar Amount 24611.00
Total Number of Units 1
Delivery Address _____

***Orders Require Signed Original Purchase Order and Tax Exempt Letter Submitted to:**

*Currie Motors Fleet
10125W Laraway
Frankfort, IL 60423
PHONE: (815)464-9200
Tom Sullivan tsullivan@curriemotors.com
Kristen De La Riva
fleetcurrie@gmail.com*

****Fleet Status is accessible by registering at www.fleet.ford.com.
Vehicles are ordered and built as indicated on this tab sheet only.
No other forms will be utilized to process orders. Production times are
greater than 26 weeks.***

Contract #165



**2021 Ford Utility Police Interceptor AWD Hybrid
Contract #152**



Currie Motors Commercial Center

Your Full Line Municipal Dealer

"Nice People to do Business With"

**HYBRID MOTOR STANDARD
MARK OPTION 99B FOR GASOLINE MOTOR**

**Order Cut Off 06/25/21
Production Delayed**



**2021 Ford Utility Police Interceptor AWD Hybrid
Contract #152
\$35,259**

MECHANICAL

3.3L Police-Calibrated V6 Direct-Injection Hybrid Engine System
 – Standard (Hybrid technology is optimal for performance and long days spent idling on the job)
 ● AWD Drivetrain – Standard for enhanced handling precision and unsurpassed traction on wet or dry surfaces
 Transmission – 10-speed automatic, police calibrated for maximum acceleration and faster closing speeds
 Lithium-Ion Battery Pack
 Brakes – Police calibrated high-performance regenerative braking system
 ● 4-Wheel heavy-duty disc w/heavy-duty front and rear calipers
 ● Brake Rotors – large mass for high thermal capacity and calipers with large swept area.
 ● Electric Power-Assist Steering (EPAS) – Heavy-Duty DC/DC converter – 220-Amp (in lieu of alternator)
 H7 AGM Battery (Standard; 800 CCA/80-amp)
 ● Cooling System – Heavy-duty, large high volume radiator, Engine oil cooler and transmission oil cooler
 ● Engine Idle Hour Meter
 ● Engine Hour Meter
 ● Powertrain mounts – Heavy-Duty
 50-State Emissions System
INTERIOR/COMFORT
 ● Cargo Area – Spacious area for police equipment; Lithium-Ion Battery Pack does not intrude into the cargo area
 ● Cargo Hooks
 ● Climate Control – Dual-Zone Electronic Automatic Temperature Control (DEATC)
 ● Door-Locks – Power – Rear-Door Handles and Locks Operable ● Fixed Pedals (Driver Dead Pedal)
 ● Floor – Flooring – Heavy-Duty Thermoplastic Elastomer
 ● Glove Box – Locking/non-illuminated
 ● Grab Handles – (1 – Front-passenger side, 2-Rear)
 ● Liftgate Release Switch located in overhead console (45 second timeout feature)
 ● Lighting – Overhead Console – Red/White Task Lighting in
 ● Overhead Console – 3rd row overhead map light
 ● Mirror – Day/night Rear View
 ● Particulate Air Filter
 ● Powerpoints – (1) First Row
 ● Rear-window Defrost
 ● Scuff Plates – Front & Rear
 ● Speed (Cruise) Control
 ● Speedometer – Calibrated (includes digital readout)
 ● Steering Wheel – Manual / Tilt, Urethane wheel finish w/Silver Painted Bezels with Speed Controls and 4-user configurable latching switches
 ● Sun visors, color-keyed, non-illuminated

INTERIOR/COMFORT (CONTINUED)

● Seats – 1st Row Police Grade Cloth Trim, Dual Front Buckets with reduced bolsters – 1st Row – Driver 6-way Power track (fore/aft. Up/down, tilt with manual recline, 2-way manual lumbar) – 1st Row – Passenger 2-way manual track (fore/aft. with manual recline) – Built-in steel intrusion plates in both driver/passenger seatbacks – 2nd Row Vinyl, 35/30/35 Split Bench Seat (manual fold-flat, no tumble) – fixed seat track
 ● Universal Top Tray – Center of IP for mounting aftermarket equipment
 ● Windows, Power, 1-touch Up/Down Front Driver/Passenger-Side with disable feature
EXTERIOR
 ● Antenna, Roof-mounted Cladding – Lower bodyside cladding MIC ● Door Handles – Black (MIC)
 ● Exhaust True Dual (down-turned)
 ● Front-Door-Lock Cylinders (Front Driver / Passenger / Liftgate)
 ● Glass – 2nd Row, Rear Quarter and Liftgate Privacy Glass
 ● Grille – Black (MIC)
 ● Headlamps – Automatic, LED Low-and-High-Beam Note: Includes Front Headlamp / Police Interceptor Housing (with LED wig-wag feature) – Pre-drilled hole for side marker police use, does not include LED strobe, but includes LED wig-wag functionality (eliminates need to drill housing assemblies and provides LED wig-wag feature) – Pre-molded side warning LED holes with standard sealed capability (does not include LED installed lights)
 ● Liftgate – Manual 1-Piece – Fixed Glass w/Door-Lock Cylinder ● Mirrors – Black Caps (MIC), Power Electric Remote, Manual Folding with Integrated Spotter (integrated blind spot mirrors not included when equipped with BLIS®)
 ● Spare – Full size 18" Tire w/TPMS
 ● Spoiler – Painted Black Tailgate Handle – (MIC)
 ● Tail lamps – LED
 ● Tires – 255/60R18 A/S BSW
 ● Wheel-Lip Molding – Black (MIC)
 ● Wheels – 18" x 8.0 painted black steel with wheel hub cover
 ● Windshield – Acoustic Laminated
POLICE UPFIT FRIENDLY
 ● Consistent 11-inch space between driver and passenger seats for aftermarket consoles (9-inch center console mounting plate)
 ● Console mounting plate
 ● Dash pass-thru opening for aftermarket wiring
 ● Headliner – Easy to service
 ● Two (2) 50 amp battery ground circuits – power distribution junction block (repositioned behind 2nd row seat floorboard).

SAFETY/SECURITY HIGHLIGHTS

- 75-mph Rear-impact Crash Tested
- Note:** The full-size spare tire secured in the factory location is necessary to achieve police-rated 75-mph rear impact crash-test performance attributes
- AdvanceTrac® w/RSC® (Roll Stability Control™) police tuned gyroscopic sensors work seamlessly with the ABS
 - Rear Video Camera with Washer (standard)
 - Airbags, dual-stage driver & front-passenger, side seat, passenger-side knee, Roll Curtain Airbags and Safety Canopy®
 - Anti-Lock Brakes (ABS) with Traction Control Brakes – Police calibrated high-performance regenerative braking system
 - Belt-Minder® (Front Driver / Passenger)
 - Child-Safety Locks (capped)
 - Individual Tire Pressure Monitoring System (TPMS)
 - LATCH (Lower Anchors and Tethers for Children) system on rear outboard seat locations
 - Seat Belts, Pretensioner/Energy-Management System w/adjustable height in 1st Row
 - SOS Post-Crash Alert System™
- WARRANTY**
- 3 Year / 36,000 Miles Bumper / Bumper
 - 8 Year / 100,000 Miles Hybrid Unique Components

FUNCTIONAL

- Audio — AM/FM / MP3 Capable / Clock / 4-speakers — Bluetooth® interface — 4.2" Color LCD Screen Center-Stack "Smart Display" Note: Standard radio does not include USB Port or Aux. Audio Input •Jack; Aux. Audio Input Jack requires SYNC 3®
 - Easy Fuel® Capless Fuel-Filler
 - Ford Telematics™ – Includes Ford Modem and complimentary 2- year trial subscription
 - Front door tether straps (driver/passenger)
 - Power pigtail harness
 - Recovery Hooks; two in front and trailer bar in rear
 - Simple Fleet Key (w/o microchip, easy to replace; 4-keys)
 - Two-way radio pre-wire
 - Two (2) 50 amp battery ground circuits – power distribution junction block (behind 2nd row passenger seat floorboard)
 - Wipers – Front Speed-Sensitive Intermittent; Rear Dual Speed Wiper
- POWERTRAIN CARE EXTENDED SERVICE PLAN**
- 5-year/100,000-mile Powertrain CARE Extended Service Plan (zero deductible) – Standard

<input checked="" type="checkbox"/>	99B	3.3L V-6 TIVCT Gasoline Motor	-\$3,165
<input type="checkbox"/>	99C	3.0 V-6 Eco-Boost Engine	\$743
<input type="checkbox"/>	41H	Engine Block Heater	\$85
<input type="checkbox"/>	19K	H8 AGM Battery (900 CCA/92 AMP)	\$103
<input type="checkbox"/>	43D	Dark Car Feature—Courtesy Lights Inoperative	\$24
<input type="checkbox"/>	942	Daytime Running Lights	\$42
<input type="checkbox"/>	17T	Dome Lamp Red/White Cargo Area	\$47
<input type="checkbox"/>	51R	Spot Light Drivers Side LED Bulb—Unity	\$371
<input type="checkbox"/>	51T	Spot Light Drivers Side LED Bulb—Whelen	\$394
<input type="checkbox"/>	51S	Spot Light Dual LED Bulbs—Unity	\$582
<input type="checkbox"/>	51V	Spot Light Dual LED Bulbs—Whelen	\$625
<input type="checkbox"/>	51P	Spot Lamp Prep Kit—Driver Side (does not include housing & bulb)	\$132
<input type="checkbox"/>	51W	Spot Lamp Prep Kit—Dual Side (does not include housing & bulb)	\$264
<input type="checkbox"/>	21L	Front Auxiliary Light Red/Blue	\$517
<input type="checkbox"/>	60A	Prewiring Grille Lamp, Siren, Speaker	\$47
<input type="checkbox"/>	63B	Side Marker LED—Red/Blue—requires option 60A	\$273
<input type="checkbox"/>	63L	Rear Quarter Glass Side Marker Lights—Red/Blue	\$541
<input type="checkbox"/>	87R	Rearview Camera—Includes Electrochromic Rearview Mirror (replaces standard camera in center stack area)	N/C
<input type="checkbox"/>	19V	Rear Camera-On-Demand	\$217
<input type="checkbox"/>	76P	Pre-Collision Assist w/ Pedestrian Detection (N/A w/ 96W)	\$136
<input type="checkbox"/>	68B	Police Perimeter Alert	\$641
<input type="checkbox"/>	68G	Rear Door Handles Inoperable/Locks Inoperable	\$71
<input type="checkbox"/>	52P	Hidden Door Lock Plunger w/ Rear Door Handles Inoperable	\$150
<input type="checkbox"/>	16C	1 st & 2 nd Row Carpet Floor Covering (includes mats)	\$118
<input type="checkbox"/>	18D	Global Lock/Unlock (Disables Auto Lock on Rear Hatch)	\$24
<input type="checkbox"/>	87P	Power Passenger Seat (8-Way) w/ manual recline/lumbar	\$306
<input type="checkbox"/>	85D	Front Console Plate Delete	N/C
<input type="checkbox"/>	85R	Rear Console Plate	\$42
<input type="checkbox"/>	90D	Ballistic Door Panels—Level III Driver Front Only	\$1,506
<input type="checkbox"/>	90E	Ballistic Door Panels—Level III Driver/Passenger Front	\$3,012
<input type="checkbox"/>	90F	Ballistic Door Panels—Level IV Driver Front Only	\$2,294
<input type="checkbox"/>	90G	Ballistic Door Panels—Level IV Driver/Passenger Front	\$4,588
<input type="checkbox"/>	96W	Front Interior Windshield Warning Lights N/A with 76P	\$1,087
<input type="checkbox"/>	96T	Rear Spoiler Traffic Light (requires 60A)	\$1,405
<input type="checkbox"/>	55B	BLIS Blind Spot Monitoring (includes manual heated mirrors)	\$512
<input type="checkbox"/>	52T	Class III Trailer Tow Light Wiring Package	\$76
<input type="checkbox"/>	549	Mirrors—Heated Side view	\$56

<input type="checkbox"/>	593	Perimeter Anti-Theft Alarm—(Requires Keyless 55F)	\$112
<input checked="" type="checkbox"/>	55F	Keyless Entry—4 Fobs	\$320
<input type="checkbox"/>	43A	Rear Auxiliary Lights	\$371
<input type="checkbox"/>	47E	12.1" Screen	\$2,580
<input type="checkbox"/>	61B	OBD-II Split Connector	\$52
<input type="checkbox"/>	68E	Noise Suppression Kit	\$183
<input type="checkbox"/>	76D	Deflector Plate	\$315

<input checked="" type="checkbox"/>	76R	Reverse Sensing	\$261
<input type="checkbox"/>		Keyed Alike Code _____ Please Specify Current Keyed Alike Code	\$47
<input type="checkbox"/>	65L	18" 5 Spoke Full Face Wheel Covers w/ Metal Clips	\$56
<input checked="" type="checkbox"/>	64E	18" Painted Aluminum Wheels	\$451
<input type="checkbox"/>	17A	Aux Air Conditioning	\$573
<input checked="" type="checkbox"/>	16D	Badge Delete	N/C
<input type="checkbox"/>	63V	Cargo Storage Vault—(lockable/ideal for contraband/small arms)	\$230
<input type="checkbox"/>	60R	Noise Suppression Bonds (Ground Straps)	\$94
<input type="checkbox"/>	18X	100 Watt Siren/Speaker (includes bracket & pigtail)	\$296
<input type="checkbox"/>	47A	Engine Idle Control	\$385
<input type="checkbox"/>		Rustproofing (Sound shield N/A)	\$395
<input type="checkbox"/>		4 Corner LED Strobes (aftermarket using 86T)	\$895
<input type="checkbox"/>		CD-ROM Service Manual	\$325
<input type="checkbox"/>		Delivery Greater than 50 Miles of Dealership	\$150
<input checked="" type="checkbox"/>		License & Title—Municipal _____ Municipal Police _____	\$203
<input type="checkbox"/>		License & Title—Passenger Plates	\$221
<input type="checkbox"/>		Dealership Handled License Plate Transfer	\$95
<input type="checkbox"/>		Manufacturer's Statement of Origin (MSO) / Customer completes their own license & title work for the municipality.	N/C

<input checked="" type="checkbox"/>		ESP Extended Warranty Prem Care 6 Year/100,000 Miles	\$2290
<input type="checkbox"/>		ESP Extended Warranty Base Care 3 Year/100,000 Miles	\$1,710
<input type="checkbox"/>		ESP Extended Warranty Powertrain 6 Year/100,000 Miles	\$1,795
<input type="checkbox"/>		ESP Extended Warranty Base Care 6 Year/100,000 Miles	\$1,850

<input type="checkbox"/>	67V	Police Wire Harness Connector Kit —Front/Rear Front —2 male 4-pin connectors for siren, 5 female 4-pin connectors for lighting/siren/speaker, 4-pin IP connector for speakers, 4-pin IP connector for siren controller connectivity, 8-pin sealed connector, & 14-pin IP connector Rear — 2 male 4-pin connectors for siren, 5 female 4-pin connectors for lighting/siren/speaker, 4-pin IP connector for speakers, 4-pin IP connector for siren controller connectivity, 8-pin sealed connector, & 14-pin IP connector	\$174
<input type="checkbox"/>	66A	Front Headlamp Lighting Solution —Includes Base LED low beam/halogen high beam w/ wig-wag function, 2 white LED side warning lights, wiring, LED lights included, controller not included (N/A w/ 67H) Recommend using 67G or 67U	\$850
<input checked="" type="checkbox"/>	65U	Police Interior Upgrade Package —1 st & 2 nd row carpet floor covering, rear cloth seats, center floor console less shifter—include console. Deletes standard console mounting plate. SYNC 3 (Enhanced Voice Recognition Communications and Entertainment System), 4.2 Color LCD Screen Center Stack, Applink, & 911 Assist (N/A w/ 67G, 67H, 67U)	\$367

<input checked="" type="checkbox"/> 66C	Rear Lighting Solution —Includes two backlit flashing LED lights (mounted to inside lift gate glass), two lift gate flashing LED lights (N/A w/ 67H)	\$428
<input type="checkbox"/> 66B	Tail Lamp Lighting Solution —Recommend using Ultimate Wiring Package (67U). Includes LED lights plus (2) rear integrated hemispheric light head white LED side warning lights in tail lamps. LED lights only. Wiring and controller not included.	\$405
<input checked="" type="checkbox"/> 86T	Tail lamp Housing Only —Includes pre-existing holes with standard twist lock sealed capability, does not include LED lights (N/A w/ 66B, 67H)	\$58
<input type="checkbox"/> 67U	Ultimate Wiring Package —Includes rear console mounting plate (85R)—contours through 2 nd row, channel for wiring, pre-wiring for grille LED lights, siren & speaker, wiring harness I/P to rear (overlay), 2 light cables—supports up to 6 LED lights (engine compartment/grille), 2 50 amp battery & ground circuits in RH rear quarter, 1 10 amp siren/speaker circuit engine cargo area, rear hatch/cargo area wiring—supports up to 6 rear LED lights (N/A w/ 65U, 67G, 67H)	\$526
<input type="checkbox"/> 67H	Ready for the Road—All-in Complete Package—Includes Police Interceptor Packages 66A, 66B, 66C plus— <ul style="list-style-type: none"> • Whelen Cencom Light Controller • Whelen Concom Relay Center/Siren Amp w/ Traffic Advisor • Light Controller/Relay Cencom Wiring • Grille LED Lights • 100 Watt Siren/Speaker • 9 I/O Digital Serial Cable (console to cargo) • Hidden Door Lock Plunger & Read Door Handles Inoperable • Rear Console Mounting Plate (N/A w/ 66A, 66B, 66C, 67G, 67U, 65U) 	\$3,415

<input type="checkbox"/> BU	Medium Brown Metallic	N/C
<input type="checkbox"/> E3	Arizona Beige Metallic Clear coat	N/C
<input type="checkbox"/> E4	Vermillion Red	N/C
<input type="checkbox"/> FT	Blue Metallic	N/C
<input type="checkbox"/> HG	Smokestone Metallic	N/C
<input type="checkbox"/> J1	Kodiak Brown Metallic	N/C
<input type="checkbox"/> JL	Dark Toreador Red Metallic	N/C
<input type="checkbox"/> JS	Iconic Silver Metallic	N/C
<input type="checkbox"/> M7	Carbonized Gray	N/C
<input type="checkbox"/> LK	Dark Blue	N/C
<input type="checkbox"/> LM	Royal Blue	N/C
<input type="checkbox"/> LN	Light Blue Metallic	N/C
<input type="checkbox"/> TN	Silver Grey Metallic	N/C
<input type="checkbox"/> UJ	Sterling Grey Metallic	N/C
<input checked="" type="checkbox"/> UM	Agate Black	N/C
<input type="checkbox"/> YG	Medium Titanium Metallic	N/C
<input type="checkbox"/> YZ	Oxford White	N/C

<input type="checkbox"/>	Charcoal Black w/ Vinyl Rear	N/C
<input checked="" type="checkbox"/>	Charcoal Black w/ Cloth Rear	\$58



Please complete the following in its entirety.

Title Information:	CITY OF BERWYN

Contact Name:	_____
Phone Number:	_____
Purchase Order Number:	_____
Ford FIN Code:	_____
Tax Exempt Number:	_____
Total Number of Units:	1
Total Dollar Amount:	36490
Delivery Address:	_____

**Orders require an original signed purchase order & tax exempt letter.
Scheduled Orders Cannot be canceled**

Currie Motors Commercial Center
10125 W. Laraway Road
Frankfort, IL 60423
(815) 464-9200

Kristen De La Riva fleetcurrie@gmail.com
Tom Sullivan tsullivan@curriemotors.com

License Plates and Titles Shipped From SOS-Delays >90 Days

Prepared for: , Berwyn Police Department

2021 Transit-250 Cargo AWD Low Roof Van 148" WB Base (R2Y)

Price Level: 115



Client Proposal

Prepared by:
THOMAS SULLIVAN
Office: 815-464-9200
Date: 04/02/2021



Prepared for:

Berwyn Police Department

Prepared by: THOMAS SULLIVAN

04/02/2021



Currie Commercial Center | 10125 W. Laraway Frankfort Illinois | 60423

2021 Transit-250 Cargo AWD Low Roof Van 148" WB Base (R2Y)

Price Level: 115

Major Equipment

(Based on selected options, shown at right)

3.5L V-6 DOHC w/port/direct injection 275hp
10 speed automatic w/OD

- * 4-wheel ABS
- * Electric parking brake
- * LT 235/65R16 C BSW AS S-rated tires
- * Advance Trac w/Roll Stability Control
- * Tinted glass
- * Bluetooth streaming audio
- * Variable intermittent wipers
- * Dual front airbags w/passenger cancel
- * Airbag occupancy sensor
- * Rear window defroster
- * Reclining front bucket seats
- * Audio control on steering wheel

Exterior: Oxford White
Interior: Dark Palazzo Gray

- * Brake assistance
- * Traction control
- * Battery with run down protection
- * Air conditioning
- * AM/FM stereo with seek-scan, auxiliary audio input, external memory control
- * Dual power remote mirrors
- * 16 x 6.5 steel wheels
- * Driver and front passenger seat mounted side airbags
- * SecuriLock immobilizer
- * Tachometer
- * Running boards

Fuel Economy

City
N/A



Hwy
N/A

As Configured Vehicle

MSRP

STANDARD VEHICLE PRICE	\$41,940.00
Order Code 101A	N/C
Engine: 3.5L PFDi V6 Flex-Fuel	Included
Transmission: 10-Spd Automatic w/OD & SelectShift	Included
3.73 Limited-Slip Axle Ratio	Included
GVWR: 9,070 lbs	Included
Tires: 235/65R16C 121/119 R AS BSW	Included
Wheels: 16" Silver Steel w/Exposed Lug Nuts	Included
Dark Palazzo Gray Vinyl Bucket Seats	Included
Vinyl Front Bucket Seats	Included
Monotone Paint Application	STD
148" Wheelbase	STD
Radio: AM/FM Stereo	Included
50-State Emissions System	STD
Auto Start-Stop Switch Delete	Included
Oxford White	N/C
Dark Palazzo Gray	N/C
Fixed Rear Cargo Door & Passenger-Side Glass	\$425.00
Rear-Window Defroster	Included

Prices and content availability as shown are subject to change and should be treated as estimates only. Actual base vehicle, package and option pricing may vary from this estimate because of special local pricing, availability or pricing adjustments not reflected in the dealer's computer system. See salesperson for the most current information.

Prepared for:

Berwyn Police Department

Prepared by: THOMAS SULLIVAN

04/02/2021



Currie Commercial Center | 10125 W. Laraway Frankfort Illinois | 60423

2021 Transit-250 Cargo AWD Low Roof Van 148" WB Base (R2Y)

Price Level: 115

<i>As Configured Vehicle</i>	MSRP
Rearview Mirror	Included
Reverse Sensing System	\$295.00
Auxiliary Heater Prep Package w/o Rear Controls	\$65.00
Running Boards	\$310.00
<hr/>	
SUBTOTAL	\$43,035.00
Destination Charge	\$1,695.00
<hr/>	
TOTAL	\$44,730.00

Prices and content availability as shown are subject to change and should be treated as estimates only. Actual base vehicle, package and option pricing may vary from this estimate because of special local pricing, availability or pricing adjustments not reflected in the dealer's computer system. See salesperson for the most current information.

Prepared for:
 Berwyn Police Department
 Prepared by: THOMAS SULLIVAN
 04/02/2021



Currie Commercial Center | 10125 W. Laraway Frankfort Illinois | 60423

2021 Transit-250 Cargo AWD Low Roof Van 148" WB Base (R2Y)

Price Level: 115

As Configured Vehicle

Code	Description	MSRP
Base Vehicle		
R2Y	Base Vehicle Price (R2Y)	\$41,940.00
Packages		
101A	Order Code 101A <i>Includes:</i> - Engine: 3.5L PFDi V6 Flex-Fuel Includes port injection. - Auto Start-Stop Switch Delete Deletes button on dash which disables auto start-stop technology. - Transmission: 10-Spd Automatic w/OD & SelectShift Includes auxiliary transmission oil cooler. - 3.73 Limited-Slip Axle Ratio - GVWR: 9,070 lbs - Tires: 235/65R16C 121/119 R AS BSW - Wheels: 16" Silver Steel w/Exposed Lug Nuts - Dark Palazzo Gray Vinyl Bucket Seats Includes 2-way manual driver seat, 2-way manual passenger seat and driver armrest. - Vinyl Front Bucket Seats - Radio: AM/FM Stereo Includes 4.0" multi-function display, Bluetooth, dual USB ports and 4 speakers (front).	N/C
Powertrain		
998	Engine: 3.5L PFDi V6 Flex-Fuel <i>Includes port injection.</i> <i>Includes:</i> - Auto Start-Stop Switch Delete Deletes button on dash which disables auto start-stop technology.	Included
44U	Transmission: 10-Spd Automatic w/OD & SelectShift <i>Includes auxiliary transmission oil cooler.</i>	Included
X7L	3.73 Limited-Slip Axle Ratio	Included
STDGV	GVWR: 9,070 lbs	Included
57A	Auto Start-Stop Switch Delete <i>Deletes button on dash which disables auto start-stop technology.</i>	Included
Wheels & Tires		
STDTR	Tires: 235/65R16C 121/119 R AS BSW	Included
STDWL	Wheels: 16" Silver Steel w/Exposed Lug Nuts	Included
Seats & Seat Trim		

Prices and content availability as shown are subject to change and should be treated as estimates only. Actual base vehicle, package and option pricing may vary from this estimate because of special local pricing, availability or pricing adjustments not reflected in the dealer's computer system. See salesperson for the most current information.

Prepared for:

Berwyn Police Department

Prepared by: THOMAS SULLIVAN

04/02/2021



Currie Commercial Center | 10125 W. Laraway Frankfort Illinois | 60423

2021 Transit-250 Cargo AWD Low Roof Van 148" WB Base (R2Y)

Price Level: 115

As Configured Vehicle (cont'd)

Code	Description	MSRP
21G	Dark Palazzo Gray Vinyl Bucket Seats <i>Includes 2-way manual driver seat, 2-way manual passenger seat and driver armrest.</i>	Included
V	Vinyl Front Bucket Seats	Included
Other Options		
PAINT	Monotone Paint Application	STD
148WB	148" Wheelbase	STD
68H	Running Boards <i>Covers the B-C pillar passenger-side.</i>	\$310.00
17B	Fixed Rear Cargo Door & Passenger-Side Glass <i>Includes: - Rear-Window Defroster - Rearview Mirror</i>	\$425.00
58U	Radio: AM/FM Stereo <i>Includes 4.0" multi-function display, Bluetooth, dual USB ports and 4 speakers (front).</i>	Included
43R	Reverse Sensing System	\$295.00
62A	Auxiliary Heater Prep Package w/o Rear Controls	\$65.00
Emissions		
425	50-State Emissions System	STD
Interior Color		
VK_03	Dark Palazzo Gray	N/C
Exterior Color		
YZ_01	Oxford White	N/C
SUBTOTAL		\$43,035.00
Destination Charge		\$1,695.00
TOTAL		\$44,730.00

Prices and content availability as shown are subject to change and should be treated as estimates only. Actual base vehicle, package and option pricing may vary from this estimate because of special local pricing, availability or pricing adjustments not reflected in the dealer's computer system. See salesperson for the most current information.

Prepared for:

Berwyn Police Department
Prepared by: THOMAS SULLIVAN
04/02/2021



Currie Commercial Center | 10125 W. Laraway Frankfort Illinois | 60423

2021 Transit-250 Cargo AWD Low Roof Van 148" WB Base (R2Y)

Price Level: 115

Pricing Summary - Single Vehicle

	MSRP
<i>Vehicle Pricing</i>	
Base Vehicle Price	\$41,940.00
Options	\$1,095.00
Colors	\$0.00
Upfitting	\$0.00
Fleet Discount	\$0.00
Destination Charge	\$1,695.00
Subtotal	\$44,730.00
<i>Discount Adjustments</i>	
Discount Adjustments	-\$11,282.00
Total	\$33,448.00

Customer Signature

Acceptance Date

Prices and content availability as shown are subject to change and should be treated as estimates only. Actual base vehicle, package and option pricing may vary from this estimate because of special local pricing, availability or pricing adjustments not reflected in the dealer's computer system. See salesperson for the most current information.

Prepared for: , Berwyn Police Department

2021 Transit-250 Cargo AWD Medium Roof Van 148" WB Base (R2C)

Price Level: 115



Client Proposal

Prepared by:
THOMAS SULLIVAN
Office: 815-464-9200
Date: 04/02/2021



Prepared for:

Berwyn Police Department
Prepared by: THOMAS SULLIVAN
04/02/2021



Currie Commercial Center | 10125 W. Laraway Frankfort Illinois | 60423

2021 Transit-250 Cargo AWD Medium Roof Van 148" WB Base (R2C)

Price Level: 115

Major Equipment

(Based on selected options, shown at right)
3.5L V-6 DOHC w/port/direct injection 275hp
10 speed automatic w/OD

- * 4-wheel ABS
- * Electric parking brake
- * LT 235/65R16 C BSW AS S-rated tires
- * Advance Trac w/Roll Stability Control
- * Tinted glass
- * Bluetooth streaming audio
- * Variable intermittent wipers
- * Dual front airbags w/passenger cancel
- * Airbag occupancy sensor
- * Rear window defroster
- * Reclining front bucket seats
- * Audio control on steering wheel

Exterior: Oxford White
Interior: Dark Palazzo Gray

- * Brake assistance
- * Traction control
- * Battery with run down protection
- * Air conditioning
- * AM/FM stereo with seek-scan, auxiliary audio input, external memory control
- * Dual power remote mirrors
- * 16 x 6.5 steel wheels
- * Driver and front passenger seat mounted side airbags
- * SecuriLock immobilizer
- * Tachometer
- * Running boards

Fuel Economy

City
N/A



Hwy
N/A

As Configured Vehicle

MSRP

STANDARD VEHICLE PRICE	\$43,090.00
Order Code 101A	N/C
Engine: 3.5L PFDi V6 Flex-Fuel	Included
Transmission: 10-Spd Automatic w/OD & SelectShift	Included
3.73 Limited-Slip Axle Ratio	Included
GVWR: 9,070 lbs	Included
Tires: 235/65R16C 121/119 R AS BSW	Included
Wheels: 16" Silver Steel w/Exposed Lug Nuts	Included
Dark Palazzo Gray Vinyl Bucket Seats	Included
Vinyl Front Bucket Seats	Included
Monotone Paint Application	STD
148" Wheelbase	STD
Radio: AM/FM Stereo	Included
50-State Emissions System	STD
Auto Start-Stop Switch Delete	Included
Oxford White	N/C
Dark Palazzo Gray	N/C
Fixed Rear Cargo Door & Passenger-Side Glass	\$425.00
Rear-Window Defroster	Included

Prices and content availability as shown are subject to change and should be treated as estimates only. Actual base vehicle, package and option pricing may vary from this estimate because of special local pricing, availability or pricing adjustments not reflected in the dealer's computer system. See salesperson for the most current information.

Prepared for:

Berwyn Police Department

Prepared by: THOMAS SULLIVAN

04/02/2021



Currie Commercial Center | 10125 W. Laraway Frankfort Illinois | 60423

2021 Transit-250 Cargo AWD Medium Roof Van 148" WB Base (R2C)

Price Level: 115

<i>As Configured Vehicle</i>	MSRP
Rearview Mirror	Included
Reverse Sensing System	\$295.00
Running Boards	\$310.00
Auxiliary Heater Prep Package w/o Rear Controls	\$65.00
<hr/>	
SUBTOTAL	\$44,185.00
Destination Charge	\$1,695.00
<hr/>	
TOTAL	\$45,880.00

Prices and content availability as shown are subject to change and should be treated as estimates only. Actual base vehicle, package and option pricing may vary from this estimate because of special local pricing, availability or pricing adjustments not reflected in the dealer's computer system. See salesperson for the most current information.

Prepared for:
 Berwyn Police Department
 Prepared by: THOMAS SULLIVAN
 04/02/2021



Currie Commercial Center | 10125 W. Laraway Frankfort Illinois | 60423

2021 Transit-250 Cargo AWD Medium Roof Van 148" WB Base (R2C)

Price Level: 115

As Configured Vehicle

Code	Description	MSRP
Base Vehicle		
R2C	Base Vehicle Price (R2C)	\$43,090.00
Packages		
101A	Order Code 101A <i>includes:</i> - Engine: 3.5L PFDi V6 Flex-Fuel Includes port injection. - Auto Start-Stop Switch Delete Deletes button on dash which disables auto start-stop technology. - Transmission: 10-Spd Automatic w/OD & SelectShift Includes auxiliary transmission oil cooler. - 3.73 Limited-Slip Axle Ratio - GVWR: 9,070 lbs - Tires: 235/65R16C 121/119 R AS BSW - Wheels: 16" Silver Steel w/Exposed Lug Nuts - Dark Palazzo Gray Vinyl Bucket Seats Includes 2-way manual driver seat, 2-way manual passenger seat and driver armrest. - Vinyl Front Bucket Seats - Radio: AM/FM Stereo Includes 4.0" multi-function display, Bluetooth, dual USB ports and 4 speakers (front).	N/C
Powertrain		
998	Engine: 3.5L PFDi V6 Flex-Fuel <i>includes:</i> Includes port injection. - Auto Start-Stop Switch Delete Deletes button on dash which disables auto start-stop technology.	Included
44U	Transmission: 10-Spd Automatic w/OD & SelectShift Includes auxiliary transmission oil cooler.	Included
X7L	3.73 Limited-Slip Axle Ratio	Included
STDGV	GVWR: 9,070 lbs	Included
57A	Auto Start-Stop Switch Delete Deletes button on dash which disables auto start-stop technology.	Included
Wheels & Tires		
STDTR	Tires: 235/65R16C 121/119 R AS BSW	Included
STDWL	Wheels: 16" Silver Steel w/Exposed Lug Nuts	Included
Seats & Seat Trim		

Prices and content availability as shown are subject to change and should be treated as estimates only. Actual base vehicle, package and option pricing may vary from this estimate because of special local pricing, availability or pricing adjustments not reflected in the dealer's computer system. See salesperson for the most current information.

Prepared for:
 Berwyn Police Department
 Prepared by: THOMAS SULLIVAN
 04/02/2021



Currie Commercial Center | 10125 W. Laraway Frankfort Illinois | 60423

2021 Transit-250 Cargo AWD Medium Roof Van 148" WB Base (R2C)

Price Level: 115

As Configured Vehicle (cont'd)

Code	Description	MSRP
21G	Dark Palazzo Gray Vinyl Bucket Seats <i>Includes 2-way manual driver seat, 2-way manual passenger seat and driver armrest.</i>	Included
V	Vinyl Front Bucket Seats	Included
Other Options		
PAINT	Monotone Paint Application	STD
148WB	148" Wheelbase	STD
68H	Running Boards <i>Covers the B-C pillar passenger-side.</i>	\$310.00
17B	Fixed Rear Cargo Door & Passenger-Side Glass <i>Includes: - Rear-Window Defroster - Rearview Mirror</i>	\$425.00
58U	Radio: AM/FM Stereo <i>Includes 4.0" multi-function display, Bluetooth, dual USB ports and 4 speakers (front).</i>	Included
43R	Reverse Sensing System	\$295.00
62A	Auxiliary Heater Prep Package w/o Rear Controls	\$65.00
Emissions		
425	50-State Emissions System	STD
Interior Color		
VK_03	Dark Palazzo Gray	N/C
Exterior Color		
YZ_01	Oxford White	N/C
SUBTOTAL		\$44,185.00
Destination Charge		\$1,695.00
TOTAL		\$45,880.00

Prices and content availability as shown are subject to change and should be treated as estimates only. Actual base vehicle, package and option pricing may vary from this estimate because of special local pricing, availability or pricing adjustments not reflected in the dealer's computer system. See salesperson for the most current information.

Prepared for:
Berwyn Police Department
Prepared by: THOMAS SULLIVAN
04/02/2021



Currie Commercial Center | 10125 W. Laraway Frankfort Illinois | 60423

2021 Transit-250 Cargo AWD Medium Roof Van 148" WB Base (R2C)

Price Level: 115

Pricing Summary - Single Vehicle

	MSRP
Vehicle Pricing	
Base Vehicle Price	\$43,090.00
Options	\$1,095.00
Colors	\$0.00
Upfitting	\$0.00
Fleet Discount	\$0.00
Destination Charge	\$1,695.00
Subtotal	\$45,880.00
Discount Adjustments	
Discount Adjustments	-\$9,212.00
Total	\$36,668.00

Customer Signature

Acceptance Date

Prices and content availability as shown are subject to change and should be treated as estimates only. Actual base vehicle, package and option pricing may vary from this estimate because of special local pricing, availability or pricing adjustments not reflected in the dealer's computer system. See salesperson for the most current information.



J-8

A Century of Progress with Pride

July 13, 2021

To: Mayor Robert J. Lovero
Members of the Berwyn City Council

Re: Recommended approval of the Berwyn Depot District Underground Utility Improvements IEPA Low Interest loan.

Project Background

The City has completed the design and bidding for the Phase 1 utilities portion, including water main replacement, sewer rehabilitation, and new water services.

Construction of Phase 1 is scheduled to start in July 2021 with completion in the fall of 2022.

Project Funding

Construction is being funded through three low interest loans provided by the Illinois Environmental Protection Agency (IEPA). The procurement process is subject to IEPA regulations contained in the Procedures for Issuing Loans from the Public Water Supply Loan Program.

"Any contract or contracts awarded under this invitation for bids are expected to be funded in part by a loan from the Illinois Environmental Protection Agency (Illinois EPA). Neither the State of Illinois nor any of its departments, agencies, or employees is or will be a party to this invitation for bids or any resulting contract. The procurement will be subject to regulations contained in the Procedures for Issuing Loans from the Public Water Supply Loan Program (35IAC Part 662), the Davis-Bacon Act (40 USC 276a through 276a-5) as defined by the United States Department of Labor, the Employment of Illinois Workers on Public Works Act (30 ILCS 570), and the "Use of American Iron and Steel" requirements as contained in Section 436 of H.R. 3547, The Consolidated Appropriations Act, 2014. This procurement is also subject to the loan recipient's policy regarding the increased use of disadvantaged business enterprises."

Loan # L175289 will fund approximately 15,000 feet of new water main. Loan # L175290 will fund approximately 6,000 feet of new sewers, point replacement, lining and enhancements to the sewer system. Finally, loan # L175902 will fund lead water service replacement within the project area and is 100% principal forgiveness.

Loan #	Program	Loan Amount	Interest Rate	Repayment Period	
L175289	DW	\$7,879,600.00	1.35%	20yr	
L175290	WW	\$7,212,676.76	1.35%	20yr	
L175902	LSLR	\$493,610.90	1.15%	20yr	100% principal forgiveness

Recommendation: I recommend approval of the IEPA low interest loan agreement for water main and sewer improvements for the Depot District utility project

Respectfully,



Robert Schiller
Director of Public Wrks



ILLINOIS ENVIRONMENTAL PROTECTION AGENCY

1021 NORTH GRAND AVENUE EAST, P.O. BOX 19276, SPRINGFIELD, ILLINOIS 62794-9276 • (217) 782-3397

JB PRITZKER, GOVERNOR

JOHN J. KIM, DIRECTOR

217:782-2027

JUN 29 2021

JUN 29 - 6 4:41

CERTIFIED MAIL

The Honorable Robert Lovero
Mayor, City of Berwyn
6700 West 26th Street
Berwyn, IL 60402-0701

Re: City of Berwyn/L175289
Loan Agreement

Dear Mayor Lovero:

It is a pleasure to advise you that your application for a Public Water Supply loan, under the provisions of the Environmental Protection Act, has been approved in the amount of \$7,879,600.00 at a 1.35% simple annual interest rate.

The Loan Agreement is enclosed in triplicate. After the Agreement is reviewed, the original and one copy should be signed by the appropriate official and returned to the Infrastructure Financial Assistance Section, Bureau of Water, P.O. Box 19276, Springfield, IL 62794-9276 as soon as it is signed, but no later than August 18, 2021. The second copy is for your records. Receipt of a written refusal or failure to return the properly executed documents within the specified time may subject the Loan Agreement to cancellation consideration.

Your attention is invited to the Standard Conditions of the Loan Agreement which outline the requirements and terms of your loan. The schedule is based on your awarding of contracts and initiating project construction promptly. Your compliance with the loan conditions and terms will facilitate our processing and your receipt of loan disbursements. In addition, by acceptance of this loan agreement, the loan recipient agrees to comply with any future reporting and/or accountability requirements that may be associated with the State Revolving Fund programs in Illinois.

For each contract awarded, please submit a copy of the executed contract; a copy of the certificate of insurance; a copy of the performance and payment bonds; and the notice to proceed as soon as these documents are available.

You are reminded that it is your responsibility as the loan recipient to maintain copies of the bids for all firms that bid on prime contracts, or provide quotes on subcontracts in accordance with the Standard Conditions. It is also your responsibility to obtain copies of all subcontracts awarded by the prime contractor and verify these contracts conform to the Standard Conditions.

2125 S. First Street, Champaign, IL 61820 (217) 278-5800

1101 Eastport Plaza Dr. Suite 100, Collinsville, IL 62234 (618) 346-5120

9511 Harrison Street, Des Plaines, IL 60016 (847) 294-4300

595 S. State Street, Elgin, IL 60123 (847) 608-3131

2309 W. Main Street, Suite 116, Marion, IL 62959 (618) 993-7200

412 SW Washington Street, Suite D, Peoria, IL 61602 (309) 671-3022

4302 N. Main Street, Rockford, IL 61103 (815) 987-7750

If you have any questions regarding this project, please contact George Lambert, the project manager, Infrastructure Financial Assistance Section, at 217 782-2027.

Congratulations on the receipt of this Loan Agreement and we look forward to working with you during the project.

Sincerely,

A handwritten signature in black ink, appearing to read 'John J. Kim', with a large, stylized flourish at the end.

John J. Kim
Director

JJK:GL n: bow grants lgts loandocuments 005289 doc-890019.docx

Attachments

cc: Terra Environmental Services
City Clerk ✓

LENDER:

Illinois Environmental Protection Agency
Bureau of Water
Infrastructure Financial Assistance Section
P.O. Box 19276
1021 North Grand Avenue, East
Springfield, IL 62794-9276

RECIPIENT:

City of Berwyn
6700 West 26th Street
Berwyn, IL 60402-0701

FEIN: 369005796

TERMS OF THE LOAN

			<u>Estimated Dates</u>
Loan amount:	\$7,879,600.00	Construction start:	07 01 2021
Annual fixed loan rate:	1.35%	Construction complete:	07 31 2022
Term:	20 years	Initiation of operation:	07 31 2022
Repayments:	Semi-Annual	Initiation of repayment period:	07 31 2022
		First repayment due:	01 31 2023
		Final repayment due:	07 31 2042

LOAN OFFER AND ACCEPTANCE

Offer by the State of Illinois Environmental Protection Agency

The Director (herein called the "Director") of the Illinois Environmental Protection Agency (herein called the "Agency") pursuant to the Environmental Protection Act, hereby offers to make a loan from the Water Revolving Fund, up to and not exceeding the above specified amount, at the fixed loan rate and repayment period given above, for the support of the efforts contained in the Project Description, herein. This Loan Offer is subject to all applicable State and Federal statutory and regulatory provisions, Standard and Special Loan Conditions, Procedures For Issuing Loans From the Public Water Supply Loan Program (35 Ill. Adm. Code 662) and the terms specified in the Letter of Transmittal, attached hereto and included herein by reference.



Agency Signature

Director

Title

John J. Kim

Name

6/29/21

Date

This offer must be accepted on or before 08/18/2021.

Acceptance on behalf of the Borrower

Authorized Representative (Signature)

Date

Name and Title of Authorized Representative (Type or Print)



ILLINOIS ENVIRONMENTAL PROTECTION AGENCY

1021 NORTH GRAND AVENUE EAST, P.O. BOX 19276, SPRINGFIELD, ILLINOIS 62794-9276 • (217) 782-3397

JB PRITZKER, GOVERNOR

JOHN J. KIM, DIRECTOR

217/782-2027

JUN 29 2021

2021 JUL -6 P 4 34

CERTIFIED MAIL

The Honorable Robert Lovero
Mayor, City of Berwyn
6700 West 26th Street
Berwyn, IL 60402-0701

Re: City of Berwyn/L175290
Loan Agreement

Dear Mayor Lovero:

It is a pleasure to advise you that your application for a Water Pollution Control loan, under the provisions of the Environmental Protection Act, has been approved in the amount of \$7,212,676.76 at a 1.35% simple annual interest rate.

The Loan Agreement is enclosed in triplicate. After the Agreement is reviewed, the original and one copy should be signed by the appropriate official and returned to the Infrastructure Financial Assistance Section, Bureau of Water, P.O. Box 19276, Springfield, IL 62794-9276 as soon as it is signed, but no later than August 18, 2021. The second copy is for your records. Receipt of a written refusal or failure to return the properly executed documents within the specified time may subject the Loan Agreement to cancellation consideration.

Your attention is invited to the Standard Conditions of the Loan Agreement which outline the requirements and terms of your loan. The schedule is based on your awarding of contracts and initiating project construction promptly. Your compliance with the loan conditions and terms will facilitate our processing and your receipt of loan disbursements. In addition, by acceptance of this loan agreement, the loan recipient agrees to comply with any future reporting and/or accountability requirements that may be associated with the State Revolving Fund programs in Illinois.

For each contract awarded, please submit a copy of the executed contract; a copy of the certificate of insurance; a copy of the performance and payment bonds; and the notice to proceed as soon as these documents are available.

You are reminded that it is your responsibility as the loan recipient to maintain copies of the bids for all firms that bid on prime contracts, or provide quotes on subcontracts in accordance with the Standard Conditions. It is also your responsibility to obtain copies of all subcontracts awarded by the prime contractor and verify these contracts conform to the Standard Conditions.

2125 S. First Street, Champaign, IL 61820 (217) 278-9800
1101 Eastport Plaza Dr., Suite 100 Collinsville, IL 62234 (618) 346-5120
9511 Harrison Street, Des Plaines, IL 60016 (847) 294-4000
595 S. State Street, Elgin, IL 60123 (847) 608-3131

2309 W. Main Street, Suite 116, Marion, IL 62959 (618) 993-7200
412 SW Washington Street, Suite D Peoria, IL 61602 (309) 671-3077
4302 N. Main Street, Rockford, IL 61103 (815) 987-7760

If you have any questions regarding this project, please contact George Lambert, the project manager, Infrastructure Financial Assistance Section, at 217/782-2027.

Congratulations on the receipt of this Loan Agreement and we look forward to working with you during the project.

Sincerely,

A handwritten signature in black ink, appearing to read 'John J. Kim', with a stylized flourish at the end.

John J. Kim
Director

JJK:GL n:\bow\grants\lgts\loandocuments\005290\doc-900018.docx

Attachments

cc: Terra Environmental Services
City Clerk ✓

LENDER:

Illinois Environmental Protection Agency
Bureau of Water
Infrastructure Financial Assistance Section
P.O. Box 19276
1021 North Grand Avenue, East
Springfield, IL 62794-9276

RECIPIENT:

City of Berwyn
6700 West 26th Street
Berwyn, IL 60402-0701

FEIN: 369005796

TERMS OF THE LOAN

			<u>Estimated Dates</u>
Loan amount:	\$7,212,676.76	Construction start:	07 01 2021
Annual fixed loan rate:	1.35%	Construction complete:	07 31 2022
Term:	20 years	Initiation of operation:	07 31 2022
Repayments:	Semi-Annual	Initiation of repayment period:	07 31 2022
		First repayment due:	01 31 2023
		Final repayment due:	07 31 2042

LOAN OFFER AND ACCEPTANCE

Offer by the State of Illinois Environmental Protection Agency

The Director (herein called the "Director") of the Illinois Environmental Protection Agency (herein called the "Agency") pursuant to the Environmental Protection Act, hereby offers to make a loan from the Water Revolving Fund, up to and not exceeding the above specified amount, at the fixed loan rate and repayment period given above, for the support of the efforts contained in the Project Description, herein. This Loan Offer is subject to all applicable State and Federal statutory and regulatory provisions, Standard and Special Loan Conditions, Procedures For Issuing Loans From the Water Pollution Control Loan Program (35 Ill. Adm. Code 365) and the terms specified in the Letter of Transmittal, attached hereto and included herein by reference.



Director
Title

John J. Kim
Name

6/29/21

Date

This offer must be accepted on or before 08/18/2021.

Acceptance on behalf of the Borrower

Authorized Representative (Signature)

Date

Name and Title of Authorized Representative (Type or Print)



ILLINOIS ENVIRONMENTAL PROTECTION AGENCY

1021 NORTH GRAND AVENUE EAST, P.O. BOX 19276, SPRINGFIELD, ILLINOIS 62794-9276 • (217) 782-3397

JB PRITZKER, GOVERNOR

JOHN J. KIM, DIRECTOR

217/782-2027

JUN 29 2021

OFFICE OF
CLERK'S
2021 JUL -6 P 4:39

CERTIFIED MAIL

The Honorable Robert Lovero
Mayor, City of Berwyn
6700 West 26th Street
Berwyn, IL 60402-0701

Re: City of Berwyn/L175902
Loan Agreement

Dear Mayor Lovero:

It is a pleasure to advise you that your application for a Public Water Supply loan, under the provisions of the Environmental Protection Act, has been approved in the amount of \$493,610.90.

The Loan Agreement is enclosed in triplicate. After the Agreement is reviewed, the original and one copy should be signed by the appropriate official and returned to the Infrastructure Financial Assistance Section, Bureau of Water, P.O. Box 19276, Springfield, IL 62794-9276 as soon as it is signed, but no later than August 18, 2021. The second copy is for your records. Receipt of a written refusal or failure to return the properly executed documents within the specified time may subject the Loan Agreement to cancellation consideration.

Your attention is invited to the Standard Conditions of the Loan Agreement which outline the requirements and terms of your loan. The schedule is based on your awarding of contracts and initiating project construction promptly. Your compliance with the loan conditions and terms will facilitate our processing and your receipt of loan disbursements. In addition, by acceptance of this loan agreement, the loan recipient agrees to comply with any future reporting and/or accountability requirements that may be associated with the State Revolving Fund programs in Illinois.

For each contract awarded, please submit a copy of the executed contract; a copy of the certificate of insurance; a copy of the performance and payment bonds; and the notice to proceed as soon as these documents are available.

You are reminded that it is your responsibility as the loan recipient to maintain copies of the bids for all firms that bid on prime contracts, or provide quotes on subcontracts in accordance with the Standard Conditions. It is also your responsibility to obtain copies of all subcontracts awarded by the prime contractor and verify these contracts conform to the Standard Conditions.

2125 S. First Street, Champaign, IL 61820 (217) 278-5800
1101 Eastport Plaza Dr., Suite 100, Collinsville, IL 62234 (618) 346-5120
9511 Harrison Street, Des Plaines, IL 60016 (847) 294-4000
595 S. State Street, Elgin, IL 60120 (847) 604-3111

2309 W. Main Street, Suite 116, Marion, IL 62959 (618) 993-7200
412 SW Washington Street, Suite D, Peoria, IL 61602 (309) 671-3022
4302 N. Main Street, Rockford, IL 61103 (815) 997-7750

If you have any questions regarding this project, please contact George Lambert, the project manager, Infrastructure Financial Assistance Section, at 217-782-2027.

Congratulations on the receipt of this Loan Agreement and we look forward to working with you during the project.

Sincerely,

A handwritten signature in black ink, appearing to read "John J. Kim". The signature is fluid and cursive, with a large loop at the end.

John J. Kim
Director

JJK:GL

Attachments

cc: Terra Environmental Services
City Clerk ✓

LOAN AGREEMENT

DRINKING WATER PROJECT: L175902

LENDER:

Illinois Environmental Protection Agency
Bureau of Water
Infrastructure Financial Assistance Section
P.O. Box 19276
1021 North Grand Avenue, East
Springfield, IL 62794-9276

RECIPIENT:

City of Berwyn
6700 West 26th Street
Berwyn, IL 60402-0701

FEIN: 369005796

TERMS OF THE LOAN

			<u>Estimated Dates</u>
Loan amount:	\$493,610.90	Construction start:	07 01 2021
Annual fixed loan rate:	1.15%	Construction complete:	07 31 2022
Term:	20 years	Initiation of operation:	07 31 2022
Repayments:	Semi-Annual	Initiation of repayment period:	07 31 2022
		First repayment due:	01 31 2023
		Final repayment due:	07 31 2042

LOAN OFFER AND ACCEPTANCE

Offer by the State of Illinois Environmental Protection Agency

The Director (herein called the "Director") of the Illinois Environmental Protection Agency (herein called the "Agency") pursuant to the Environmental Protection Act, hereby offers to make a loan from the Water Revolving Fund, up to and not exceeding the above specified amount, at the fixed loan rate and repayment period given above, for the support of the efforts contained in the Project Description, herein. This Loan Offer is subject to all applicable State and Federal statutory and regulatory provisions, Standard and Special Loan Conditions, Procedures For Issuing Loans From the Public Water Supply Loan Program (35 Ill. Adm. Code 662) and the terms specified in the Letter of Transmittal, attached hereto and included herein by reference.



Agency Signature

Director

Title

John J. Kim

Name

6/29/21

Date

This offer must be accepted on or before 08/18/2021.

Acceptance on behalf of the Borrower

Authorized Representative (Signature)

Date

Name and Title of Authorized Representative (Type or Print)



J-9

BERWYN PUBLIC LIBRARY

July 8, 2021

Honorable Mayor Robert J. Lovero
Members of City Council
City of Berwyn
6700 W 26th Street
Berwyn IL 60402

Re: Purchase of new service desks for Library

Mayor Lovero and Members of City Council,

As the Library moves toward self-checkout options for our patrons, we recognize the need to replace our current Circulation Desk to accommodate the self-checkout kiosks. Further, in our effort to increase our customer service and accessibility for our patrons, we are looking to create one central service desk to replace two existing service desks. This central service desk will allow patrons to be assisted in one location rather than being directed to various points of service.

Attached with this communication is a quotation from Library Furniture International for the purchase and installation of the two requested service desks. Library Furniture International is an approved vendor of the Interlocal Purchasing System known as TIPS. This organization complies with competitive bidder requirements and criteria.

With this quotation, and the proposal derived from the TIPS Purchasing Cooperative, I am requesting City Council to waive the sealed bidding process requirement and approve this purchase in the amount of \$64,768.35. Funding for this project was approved by the Berwyn Public Library Board of Trustees at their June 21, 2021 meeting, and will be provided from the Veverka endowment fund account.

Respectfully submitted,

A handwritten signature in blue ink, appearing to read 'Tammy Sheedy', written over a blue line.

Tammy Sheedy
Library Director



6/29/2021

Factory: Multiple

Lead Time: 8-10 weeks

LFI QT-2379 Proposal For:

Berwyn Public Library, IL

Library Furniture International
797 Glenn Ave
Wheeling IL 60090
ph: 847-564-8497
fax: 847-564-9337
Tips #200301

QTY	MFG	CATALOG NO.	DESCRIPTION	UNIT NET	EXTENSION
1	Nienkamper		Half-Circle Desk 1		\$ 22,640.00
		LD-19280C	<p>Vox Circulation Desk - Half Round Shape Overall dim.: 192" L x 80" D x 29" H</p> <p>Consisting of the following: Top in Formica - Concrete Formwood #6362-NG p-lam finish with (2) 18"W x 9"H privacy acrylic screens (clear frosted) & (2) 4" x 2" rectangle plastic grommets, color: TBD</p> <p>Desk top: 32"D Taper edge Base panels in Formica - Basal Slate #3690-34 p-lam finish Base extrusions in clear aluminum finish Wire management tray, to be priced separately With 4"H recessed toe kick in Homapal # 444N finish Desk from left to right when user seated: Desk top with base supports, top in 2 sections with 2 privacy screens and 2 plastic grommets (2) 18-5/8"L x 20"D x 27-3/8"H movable pedestal BBF storage, to be priced separately</p>		
2			<p>Mobile Pedestal - 2 Box/1 File 18-5/8" x 20" x 27-3/8"H Top, front & case in Formica - Basal Slate #3690-34 p-lam finish Pull: TBD With face lock</p>		
4	WMT		<p>Plastic Wire Management Tray 18-3/4" L x 8-5/32" D x 3-11/16" H Black plastic finish</p> <p>As per drawing # Q21-139-01</p>		



6/29/2021

Factory: Multiple

Lead Time: 8-10 weeks

LFI QT-2379 Proposal For:

Berwyn Public Library, IL

Library Furniture International
797 Glenn Ave
Wheeling IL 60090
ph: 847-564-9497
fax: 847-564-9337
Tips #200301

QTY	MFG	CATALOG NO	DESCRIPTION	UNIT NET	EXTENSION
1	Nienkamper		Half-Circle Desk 2		\$ 23,926.00
1		LD-19280C	<p>Vox Circulation Desk - Half Round Shape with ADA Access Overall dim.: 192" L x 80" D x 29" H</p> <p>Consisting of the following: Top in Formica - Concrete Formwood #6362-NG p-lam finish with (2) 18"W x 9"H privacy acrylic screens (clear frosted) & (2) 4" x 2" rectangle plastic grommets, color: TBD</p> <p>Desk top: 32"D Taper edge Base panels in Formica - Basal Slate #3690-34 p-lam finish Base extrusions in clear aluminum finish Wire management tray, to be priced separately With 4"H recessed toe kick in Homopal # 444N finish Desk from left to right when user seated: Desk top with base supports, top in 2 sections with 2 privacy screens and 2 plastic grommet; 29"W x 26-1/2"D ADA recessed access back at the end (2) 18-5/8"L x 20"D x 27-3/4"H movable pedestal BBF storage, to be priced separately</p>		
2			<p>Mobile Pedestal - 2 Box/1 File 18-5/8" x 20" x 27-3/8"H Top, front & case in Formica - Basal Slate #3690-34 p-lam finish Pull: TBD With face lock</p>		
4		WMT	<p>Plastic Wire Management Tray 16-3/4" L x 8-5/32" D x 3-11/16" H Black plastic finish</p> <p>As per drawing # Q21-139-02</p>		

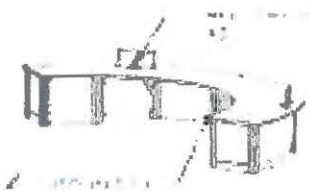

6/29/2021

LFI QT-2379 Proposal For:

Library Furniture International
797 Glenn Ave
Wheeling IL 60090
ph: 847-564-9497
fax: 847-564-9337
Tips #200301

Factory: Multiple

Berwyn Public Library, IL

Lead Time: 8-10 weeks

QTY	MFG	CATALOG NO	DESCRIPTION	UNIT NET	EXTENSION
1	Nienkamper		Desk with Book Drop		\$ 13,483.57
1	VSD-14430		<p>Vox Reception Straight Desk Overall dim. 144"L x 30"D x 30"H</p> <p>Consisting of the following: Top in Formica - Concrete Formwood #6362-NG p-lam finish</p> <p>Desk top: 30"D with 2" overhang Taper edge Base panels in Formica - Basal Slate #3690-34 p-lam finish Base extrusions in clear aluminum finish (2) 4" x 2" rectangle plastic grommets & base support (2) Vox power channel A cluster, each channel contains (1) duplex hard-wired power unit (2) Standard wire troughs, to be priced separately With 4"H recessed toe kick in Homapal #444N finish (1) Book drop, location TBD</p>		
2			<p>Mobile Pedestal - 2 Box/1 File 20"W x 24"D x 28"H Top, front & case in Formica - Basal Slate #3690-34 p-lam finish Pull: TBD</p>		
2	S-WT		<p>Standard Wire Tough Plastic finish Mounted on the modesty panel</p>		
2			<p>Power Strips, 6 outlet</p>		
TOTAL FOB FACTORY					\$ 60,029.57
INSTALLATION + FREIGHT <i>* non union / non-prevailing wage *</i>					\$ 4,738.78
TOTAL					\$ 64,768.35
50% DEPOSIT					\$ 32,384

6/29/2021

Factory: Multiple

Lead Time: 8-10 weeks

LFI QT-2379 Proposal For:

Berwyn Public Library, IL

Library Furniture International
797 Glenn Ave
Wheeling IL 60090
ph: 847-564-9497
fax: 847-564-9337
Tips #200301

QTY	MFG	CATALOG NO	DESCRIPTION	UNIT NET	EXTENSION
<p>QUOTATION TERMS</p> <ul style="list-style-type: none"> * quotes are valid for 60 days * quotes are based on stated quantities; any change in quantity may require re-quoting * prices include standard materials/finishes unless otherwise noted * customer is responsible for verifying all final details of order including, but not limited to, size, color, finish, etc.; if there are any questions on this quote, please contact LFI at 847-564-9497 to clarify details prior to accepting quote * LFI assumes use of customer's dumpster for waste removal. If customer requests LFI to provide dumpster, additional costs will be billed to customer. * Storage Costs—if finished product requires storage at LFI warehouse due to customer's site not being ready for installation at the agreed upon time, LFI reserves the right to assess a storage charge <p>PAYMENT TERMS</p> <p>50% deposit; balance due upon completion</p> <p>TO ACCEPT THIS QUOTE:</p> <ul style="list-style-type: none"> * sign and date below as formal acknowledgement of the quote terms * please forward a deposit if one is required per the quote terms * please fax back to LFI at 847-564-9337 and we will begin processing your order * LFI will coordinate and schedule in-bound freight of your order. * An LFI installer will meet the delivery truck, off-load, unpack, place items and inspect your order for damage. If there is damage or missing items, LFI will handle the claim and coordination with factory. * By NOT contracting LFI for installation, then the client is responsible for handling all issues mentioned above. LFI will provide the name and tracking number of the freight carrier, however, the client is responsible for making freight claims. * Factories and freight carriers will require digital photography of any damage related issues. <p>Signature _____ Date _____</p>					
TOTAL				\$	64,768.35

VOX RECEPTION DESK

TAG : BERWYN PUBLIC LIBRARY
 CIRCULATION DESK 1, OPTION B
 QTY : 1 REQUIRED

FINISHES : P-LAM TOP (FORMICA CONCRETE FORMWOOD, 6362-NG)
 P-LAM MODESTIES AND BASE PANELS (FORMICA BASALT SLATE, 3690-34)
 4" HOMAPAL KICK (HOMAPAL 444N)
 CLEAR ALUMINUM BASE EXTRUSIONS
 1/4" ACRYLIC SCREENS (CLEAR FROSTED)

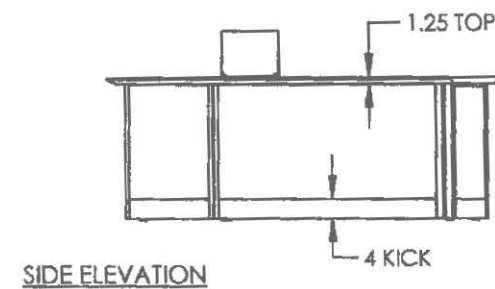
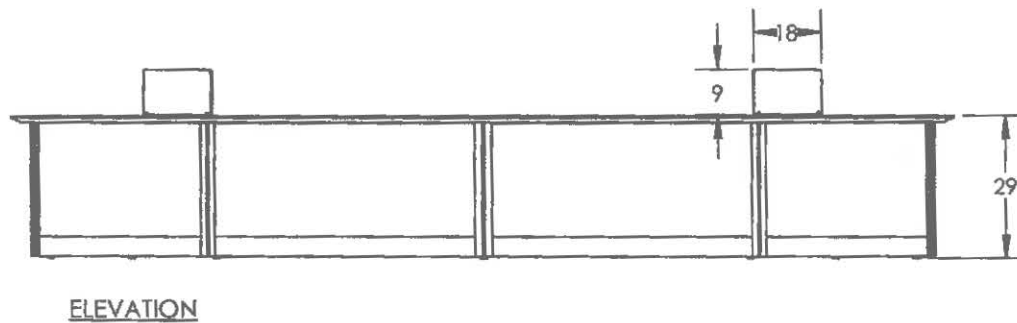
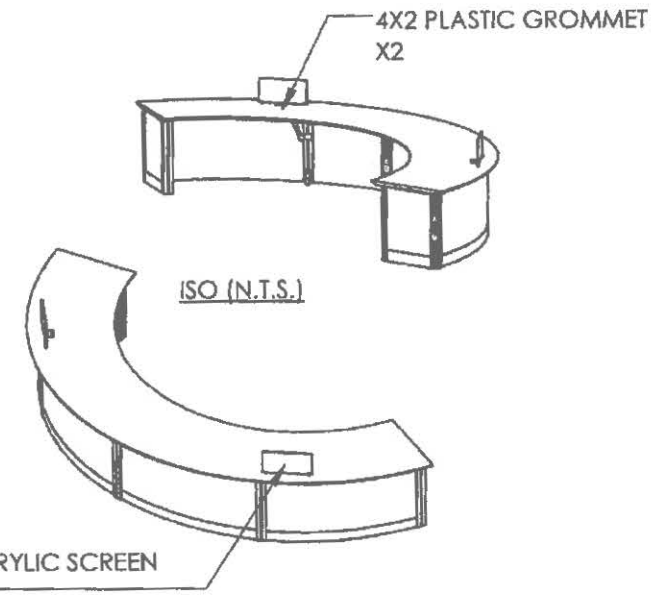
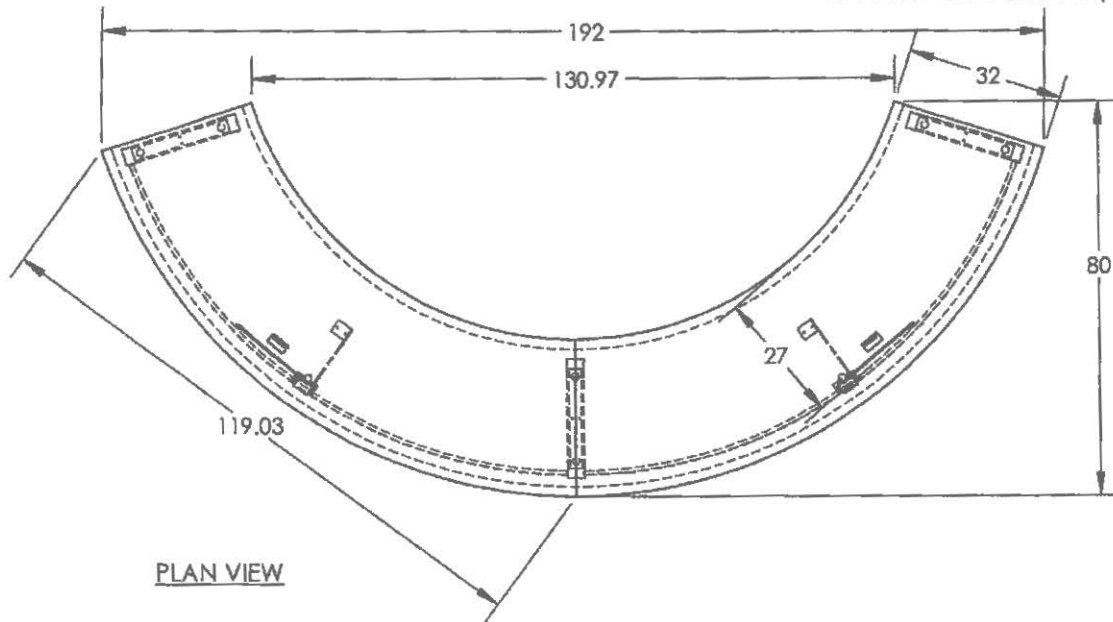

nienkämper 267 Finchdene Square, Scarborough, Ontario, Canada, M1X 1B8 Tel 416 298 6700 Fax 416 298 9636 www.nienkamper.com design@nienkamper.com	OC-Project: Q21-139	Title: BERWYN PUBLIC LIBRARY		Drawing No. Q21-139-03	Date: MAY 4, 2021	Issue Drawing To:	
	THIS DRAWING IS CONFIDENTIAL AND PROPRIETARY. NO PART OF THIS DRAWING MAY BE COPIED, DISCLOSED TO ANY THIRD PARTY OR USED FOR ANY PURPOSE WITHOUT THE EXPRESS WRITTEN AUTHORIZATION OF NIENKÄMPER FURNITURE & ACCESSORIES		Drawn: DT Part#: X.X	Scale: N.T.S CS. Rep: RS	Dwg For: CLIENT Rev Details: REV FINISHES	Rev Date: JUNE 28, 2021 / DT.	Revision No. R-1

VOX RECEPTION DESK

TAG : BERWYN PUBLIC LIBRARY
 CIRCULATION DESK 2, OPTION B
 QTY : 1 REQUIRED

FINISHES : P-LAM TOP (FORMICA CONCRETE FORMWOOD, 6362-NG)
 P-LAM MODESTIES AND BASE PANELS (FORMICA BASALT SLATE, 3690-34)
 4" HOMAPAL KICK (HOMAPAL 444N)
 CLEAR ALUMINUM BASE EXTRUSIONS
 1/4" ACRYLIC SCREENS (CLEAR FROSTED)

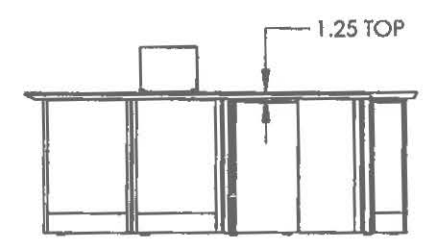
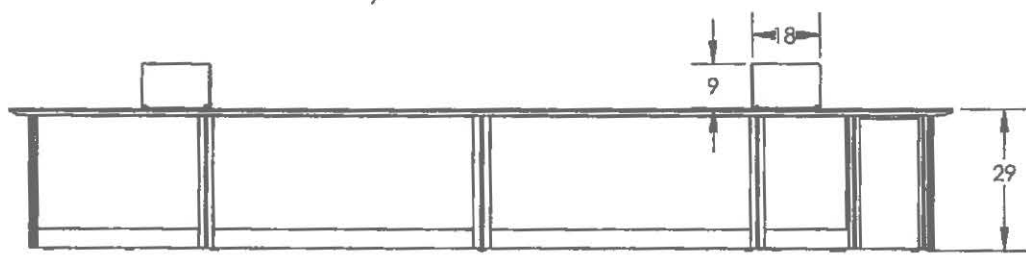
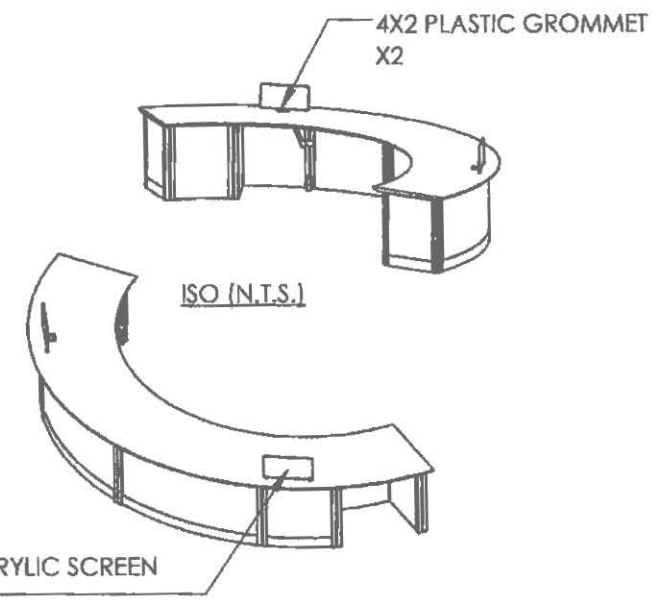
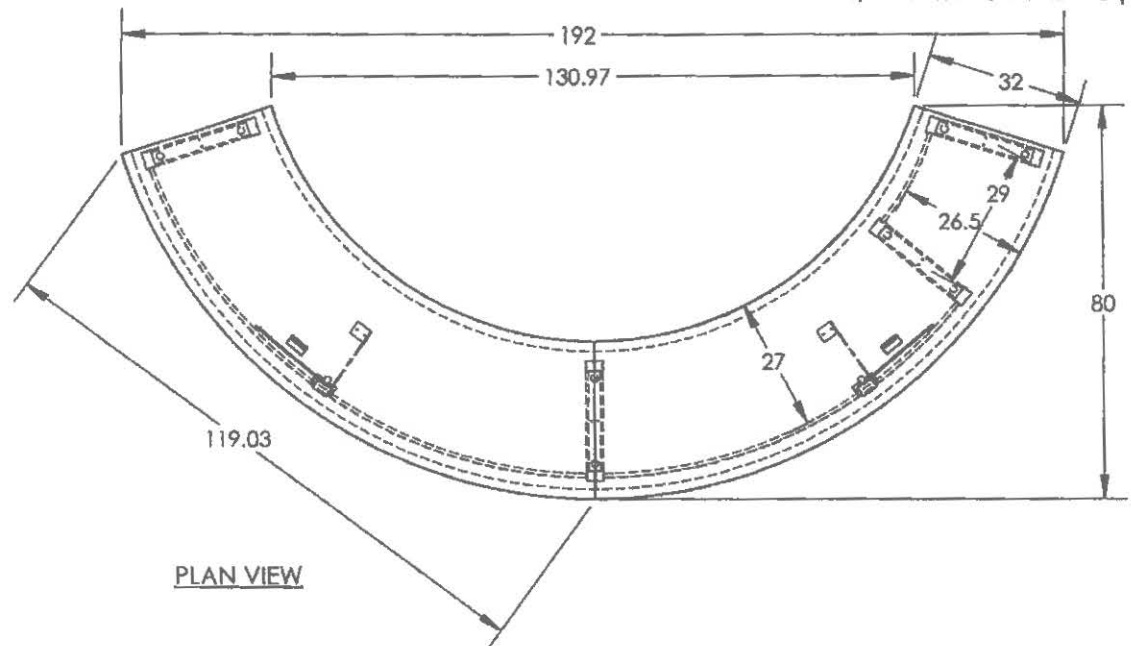

nienkämper 257 Finchdene Square, Scarborough, Ontario, Canada, M1X 1B9 Tel 416 298 5700 Fax 416 298 9636 www.nienkammer.com desk@nienkammer.com	OC-Project: Q21-139	Title: BERWYN PUBLIC LIBRARY	Drawing No: Q21-139-04	Date: MAY 4, 2021	Issue Drawing To:
	THIS DRAWING IS CONFIDENTIAL AND PROPRIETARY. NO PART OF THIS DRAWING MAY BE COPIED, DISCLOSED TO ANY THIRD PARTY OR USED FOR ANY PURPOSE WITHOUT THE EXPRESS WRITTEN AUTHORIZATION OF NIENKÄMPER FURNITURE & ACCESSORIES	Drawn: DT PARTS: X.X	Scale: N.T.S CS. Rep: RS	Dwg For: CLIENT Rev Details: REV FINISHES	Rev Date: JUNE 28, 2021 / DT

VOX RECEPTION DESK

TAG : BERWYN PUBLIC LIBRARY
 CIRCULATION DESK 3
 QTY : 1 REQUIRED

FINISHES : P-LAM TOP (FORMICA CONCRETE FORMWOOD, 6362-NG)
 P-LAM MODESTIES AND BASE PANELS (FORMICA BASALT SLATE, 3690-34)
 4" HOMAPAL KICK (HOMAPAL 444N)
 CLEAR ALUMINUM BASE EXTRUSIONS
 1/4" ACRYLIC SCREENS (CLEAR FROSTED)

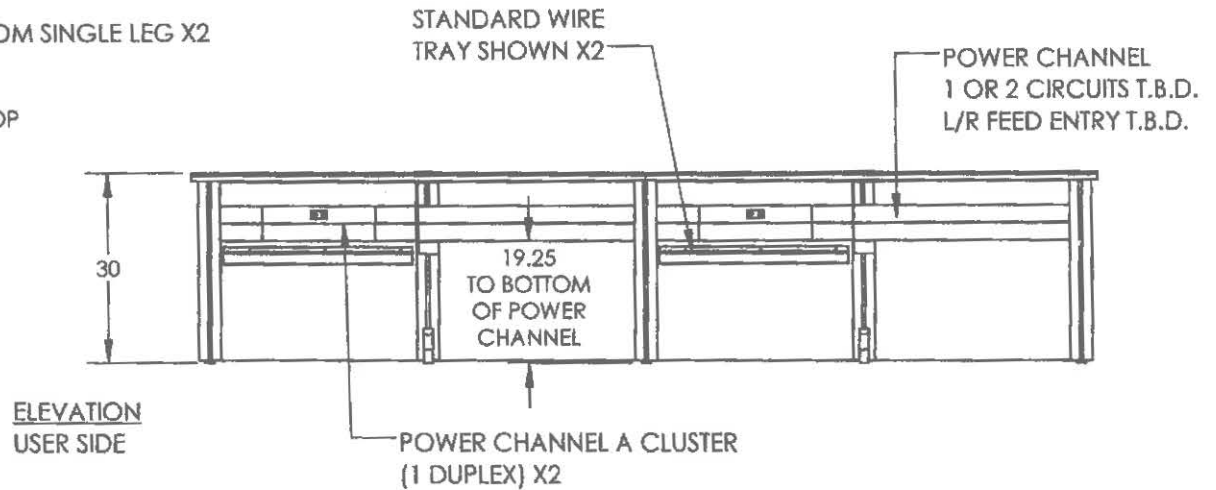
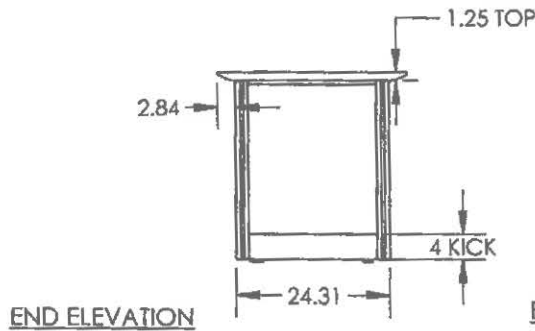
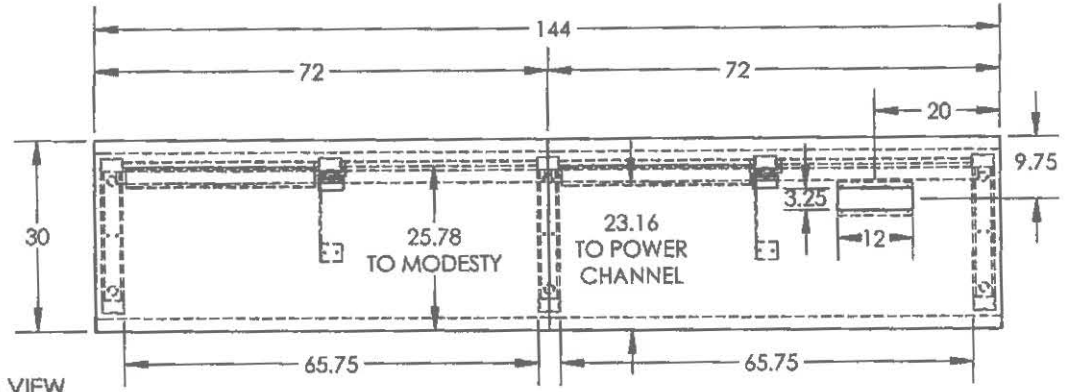
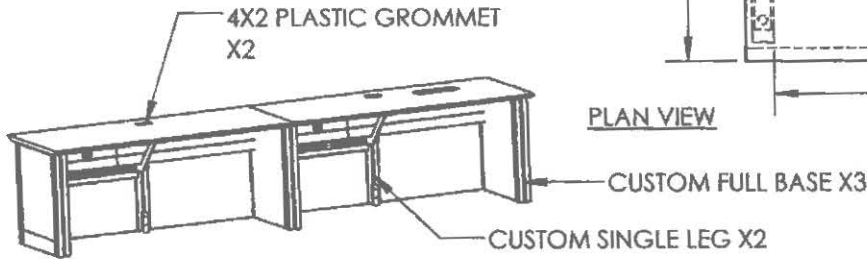
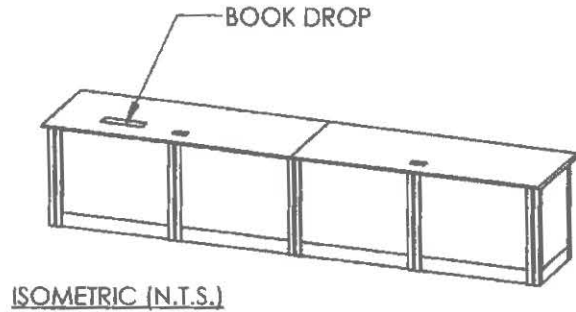

nienkämper 257 Finchdene Square, Scarborough, Ontario, Canada, M1X 1E9 Tel 416 298 6700 Fax 416 298 9536 www.nienkammer.com design@nienkammer.com	OC-Project: Q21-139	Title: BERWYN PUBLIC LIBRARY	Drawing No: Q21-139-05	Date: JUNE 21, 2021	Issue Drawing To:	
	THIS DRAWING IS CONFIDENTIAL AND PROPRIETARY. NO PART OF THIS DRAWING MAY BE COPIED, DISCLOSED TO ANY THIRD PARTY OR USED FOR ANY PURPOSE WITHOUT THE EXPRESS WRITTEN AUTHORIZATION OF NIENKÄMPER FURNITURE & ACCESSORIES	Drawn: DT	Scale: N.T.S	Dwg For: CLIENT	Rev Date: JUNE 28, 2021 / DT	Revision No.
		PART#: X.X	CS. Rep: RS	Rev Details: REV FINISHES REM ACRYLIC SCREENS	R-2	CS CUST SERV

nienkämper

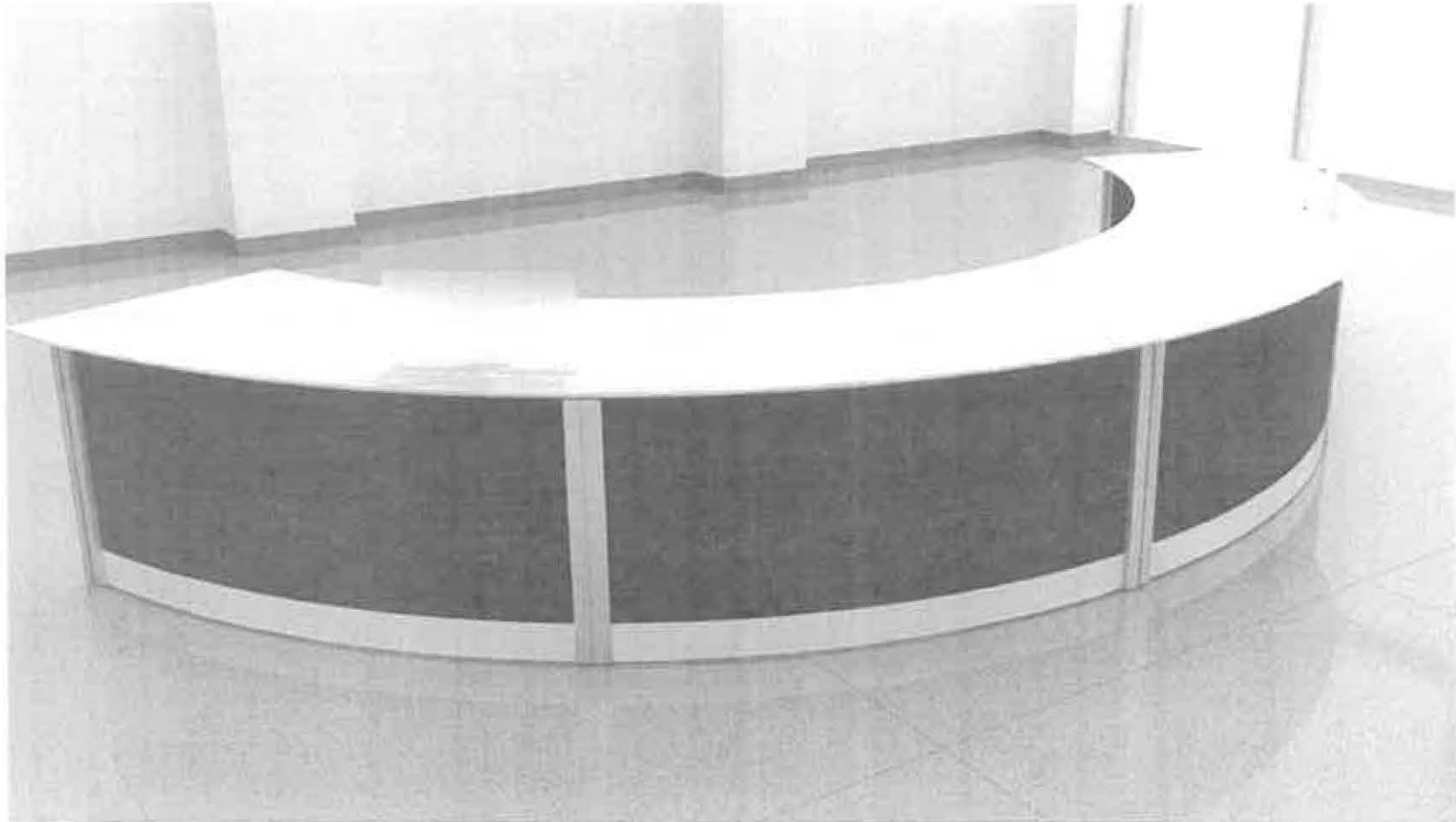

Tag: VOX RECEPTION DESK - CIRCULATION DESK 2
OC / Quote: Q21-139
Client: BERWYN PUBLIC LIBRARY
Date: JUNE 28, 2021
Drawn By: DT

THIS DRAWING IS CONFIDENTIAL AND PROPRIETARY. NO PART OF THIS DRAWING MAY BE COPIED, DISCLOSED TO ANY THIRD PARTY OR USED FOR ANY PURPOSE, WITHOUT THE EXPRESS WRITTEN AUTHORIZATION OF NIENKAMPER FURNITURE & ACCESSORIES

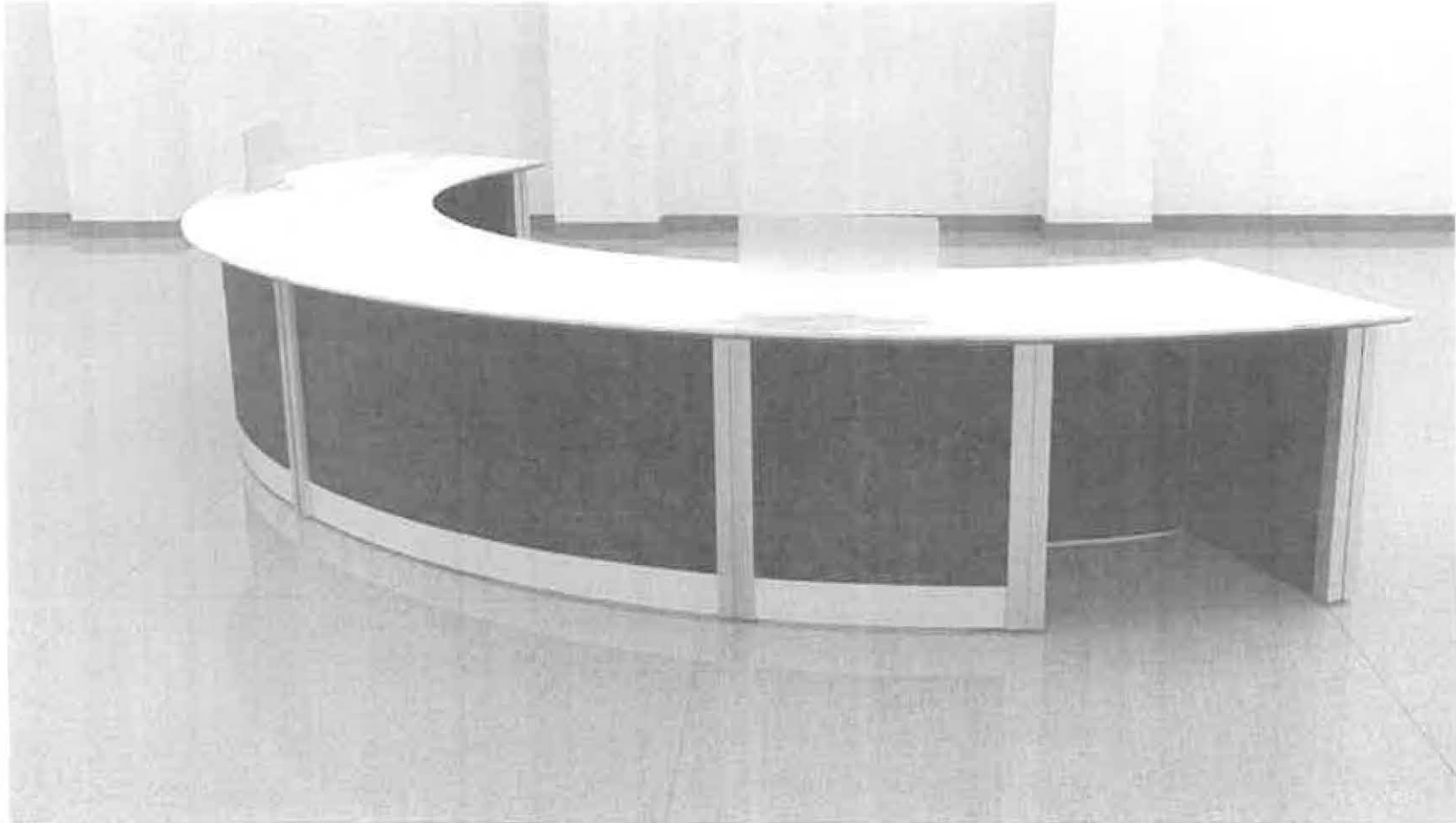

Tag: VOX RECEPTION DESK - CIRCULATION DESK 2
OC / Quote: Q21-139
Client: BERWYN PUBLIC LIBRARY
Date: JUNE 28, 2021
Drawn By: DT

THIS DRAWING IS CONFIDENTIAL AND PROPRIETARY. NO PART OF THIS DRAWING MAY BE
COPIED, DISCLOSED TO ANY THIRD PARTY OR USED FOR ANY PURPOSE, WITHOUT THE
EXPRESS WRITTEN AUTHORIZATION OF NIENKAMPER FURNITURE & ACCESSORIES

nienkämper

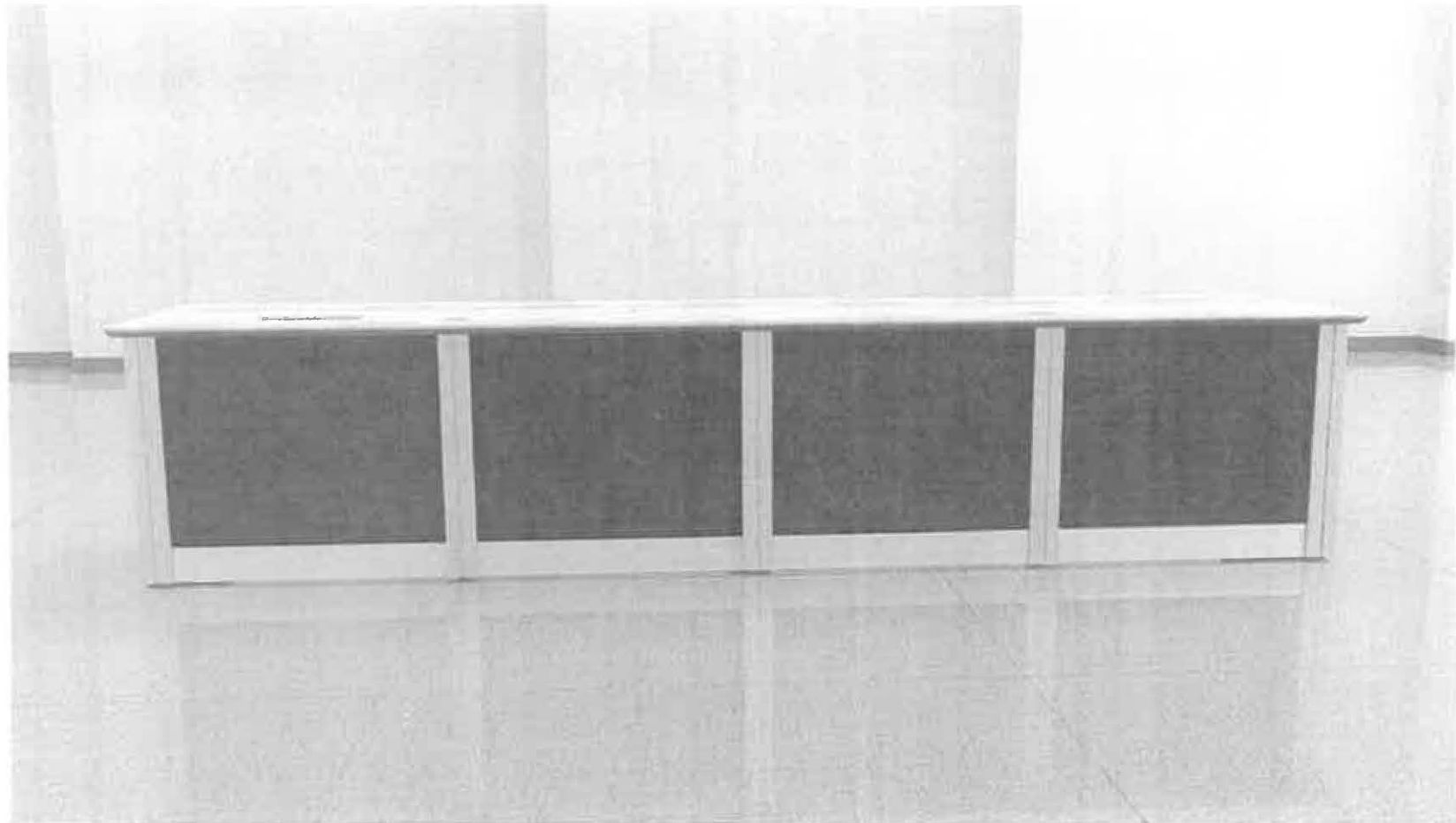

Tag: VOX RECEPTION DESK - CIRCULATION DESK 3
OC / Quote: Q21-139
Client: BERWYN PUBLIC LIBRARY
Date: JUNE 28, 2021
Drawn By: DT

THIS DRAWING IS CONFIDENTIAL AND PROPRIETARY. NO PART OF THIS DRAWING MAY BE COPIED, DISCLOSED TO ANY THIRD PARTY OR USED FOR ANY PURPOSE, WITHOUT THE EXPRESS WRITTEN AUTHORIZATION OF NIENKAMPER FURNITURE & ACCESSORIES

nienkämper



Tag: VOX RECEPTION DESK - CIRCULATION DESK 3
OC / Quote: Q21-139
Client: BERWYN PUBLIC LIBRARY
Date: JUNE 28, 2021
Drawn By: DT

THIS DRAWING IS CONFIDENTIAL AND PROPRIETARY. NO PART OF THIS DRAWING MAY BE COPIED, DISCLOSED TO ANY THIRD PARTY OR USED FOR ANY PURPOSE, WITHOUT THE EXPRESS WRITTEN AUTHORIZATION OF NIENKAMPER FURNITURE & ACCESSORIES



BERWYN PUBLIC LIBRARY

July 8, 2021

Honorable Mayor Robert J. Lovero
Members of City Council
City of Berwyn
6700 W 26th Street
Berwyn IL 60402

Re: Purchase of new service desks for Library

Mayor Lovero and Members of City Council,

As the Library moves toward self-checkout options for our patrons, we recognize the need to replace our current Circulation Desk to accommodate the self-checkout kiosks. Further, in our effort to increase our customer service and accessibility for our patrons, we are looking to create one central service desk to replace two existing service desks. This central service desk will allow patrons to be assisted in one location rather than being directed to various points of service.

Attached with this communication is a quotation from Library Furniture International for the purchase and installation of the two requested service desks. Library Furniture International is an approved vendor of the Interlocal Purchasing System known as TIPS. This organization complies with competitive bidder requirements and criteria.

With this quotation, and the proposal derived from the TIPS Purchasing Cooperative, I am requesting City Council to waive the sealed bidding process requirement and approve this purchase in the amount of \$64,768.35. Funding for this project was approved by the Berwyn Public Library Board of Trustees at their June 21, 2021 meeting, and will be provided from the Veverka endowment fund account.

Respectfully submitted,

Tammy Sheedy
Library Director



6/29/2021

Factory: Multiple

Lead Time: 8-10 weeks

LFI QT-2379 Proposal For:

Berwyn Public Library, IL

Library Furniture International
797 Glenn Ave
Wheeling IL 60090
ph: 847-564-9497
fax: 847-564-9337
Tips #200301

QTY	MFG	CATALOG NO	DESCRIPTION	UNIT NET	EXTENSION
1	Nienkamper		Half-Circle Desk 1		\$ 22,640.00
1		LD-19280C	<p>Vox Circulation Desk - Half Round Shape Overall dim.: 192" L x 80" D x 29" H</p> <p>Consisting of the following: Top in Formica - Concrete Formwood #6362-NG p-lam finish with (2) 18"W x 9"H privacy acrylic screens (clear frosted) & (2) 4" x 2" rectangle plastic grommets, color: TBD</p> <p>Desk top: 32"D Taper edge Base panels in Formica - Basal Slate #3690-34 p-lam finish Base extrusions in clear aluminum finish Wire management tray, to be priced separately With 4"H recessed toe kick in Homapal # 444N finish Desk from left to right when user seated: Desk top with base supports, top in 2 sections with 2 privacy screens and 2 plastic grommets (2) 18-5/8"L x 20"D x 27-3/8"H movable pedestal BBF storage, to be priced separately</p>		
2			<p>Mobile Pedestal - 2 Box/1 File 18-5/8" x 20" x 27-3/8"H Top, front & case in Formica - Basal Slate #3690-34 p-lam finish Pull: TBD With face lock</p>		
4		WMT	<p>Plastic Wire Management Tray 18-3/4" L x 8-5/32" D x 3-11/16" H Black plastic finish</p> <p>As per drawing # Q21-139-01</p>		



6/29/2021

Factory: Multiple

Lead Time: 8-10 weeks

LFI QT-2379 Proposal For:
Berwyn Public Library, IL

Library Furniture International
797 Glenn Ave
Wheeling IL 60090
ph: 847-564-8497
fax: 847-564-8337
Tips #200301

QTY	MFG	CATALOG NO	DESCRIPTION	UNIT NET	EXTENSION
1	Nienkamper		Half-Circle Desk 2		\$ 23,926.00
1		LD-19280C	<p>Vox Circulation Desk - Half Round Shape with ADA Access Overall dim.: 192" L x 80" D x 29" H</p> <p>Consisting of the following: Top in Formica - Concrete Formwood #6362-NG p-lam finish with (2) 18"W x 9"H privacy acrylic screens (clear frosted) & (2) 4" x 2" rectangle plastic grommets, color: TBD</p> <p>Desk top: 32"D Taper edge Base panels in Formica - Basal Slate #3690-34 p-lam finish Base extrusions in clear aluminum finish Wire management tray, to be priced separately With 4"H recessed toe kick in Homapal # 444N finish Desk from left to right when user seated: Desk top with base supports, top in 2 sections with 2 privacy screens and 2 plastic grommet; 29"W x 26-1/2"D ADA recessed access back at the end (2) 18-5/8"L x 20"D x 27-3/4"H movable pedestal BBF storage, to be priced separately</p>		
2			<p>Mobile Pedestal - 2 Box/1 File 18-5/8" x 20" x 27-3/8"H Top, front & case in Formica - Basal Slate #3690-34 p-lam finish Pull: TBD With face lock</p>		
4	WMT		<p>Plastic Wire Management Tray 16-3/4" L x 8-5/32" D x 3-11/16" H Black plastic finish</p> <p>As per drawing # Q21-139-02</p>		

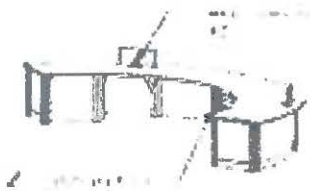

6/29/2021

Factory: Multiple

Lead Time: 8-10 weeks

LFI QT-2379 Proposal For:

Berwyn Public Library, IL

Library Furniture International
797 Glenn Ave
Wheeling IL 60090
ph: 847-564-9497
fax: 847-564-9337
Tips #200301

QTY	MFG	CATALOG NO	DESCRIPTION	UNIT NET	EXTENSION
1	Nienkamper		Desk with Book Drop		\$ 13,463.57
1		VSD-14430	Vox Reception Straight Desk Overall dim. 144"L x 30"D x 30"H Consisting of the following: Top in Formica - Concrete Formwood #6362-NG p-lam finish Desk top: 30"D with 2" overhang Taper edge Base panels in Formica - Basal Slate #3690-34 p-lam finish Base extrusions in clear aluminum finish (2) 4" x 2" rectangle plastic grommets & base support (2) Vox power channel A cluster, each channel contains (1) duplex hard-wired power unit (2) Standard wire troughs, to be priced separately With 4"H recessed toe kick in Homapal #444N finish (1) Book drop, location TBD		
2			Mobile Pedestal - 2 Box/1 File 20"W x 24"D x 28"H Top, front & case in Formica - Basal Slate #3690-34 p-lam finish Pull: TBD		
2	S-WT		Standard Wire Tough Plastic finish Mounted on the modesty panel		
2			Power Strips, 6 outlet		
TOTAL FOB FACTORY					\$ 60,029.57
INSTALLATION + FREIGHT <i>* non union / non-prevailing wage *</i>					\$ 4,738.78
TOTAL					\$ 64,768.35
50% DEPOSIT					\$ 32,384

6/29/2021

Factory: Multiple

Lead Time: 8-10 weeks

LFI QT-2379 Proposal For:

Berwyn Public Library, IL

Library Furniture International
797 Glenn Ave
Wheeling IL 60090
ph: 847-564-9497
fax: 847-564-9337
Tips #200301

QTY	MFG	CATALOG NO	DESCRIPTION	UNIT NET	EXTENSION
-----	-----	------------	-------------	----------	-----------

QUOTATION TERMS

- * quotes are valid for 60 days
- * quotes are based on stated quantities; any change in quantity may require re-quoting
- * prices include standard materials/finishes unless otherwise noted
- * customer is responsible for verifying all final details of order including, but not limited to, size, color, finish, etc.; if there are any questions on this quote, please contact LFI at 847-564-9497 to clarify details prior to accepting quote
- * LFI assumes use of customer's dumpster for waste removal. If customer requests LFI to provide dumpster, additional costs will be billed to customer.
- * Storage Costs—if finished product requires storage at LFI warehouse due to customer's site not being ready for installation at the agreed upon time, LFI reserves the right to assess a storage charge

PAYMENT TERMS

50% deposit, balance due upon completion

TO ACCEPT THIS QUOTE:

- * sign and date below as formal acknowledgement of the quote terms
- * please forward a deposit if one is required per the quote terms
- * please fax back to LFI at 847-564-9337 and we will begin processing your order
- * LFI will coordinate and schedule in-bound freight of your order.
- * An LFI installer will meet the delivery truck, off-load, unpack, place items and inspect your order for damage. If there is damage or missing items, LFI will handle the claim and coordination with factory.
- * By NOT contracting LFI for installation, then the client is responsible for handling all issues mentioned above. LFI will provide the name and tracking number of the freight carrier, however, the client is responsible for making freight claims.
- * Factories and freight carriers will require digital photography of any damage related issues.

Signature

Date

TOTAL \$ 64,768.35

VOX RECEPTION DESK

TAG : BERWYN PUBLIC LIBRARY
 CIRCULATION DESK 1, OPTION B
 QTY : 1 REQUIRED

FINISHES : P-LAM TOP (FORMICA CONCRETE FORMWOOD, 6362-NG)
 P-LAM MODESTIES AND BASE PANELS (FORMICA BASALT SLATE, 3690-34)
 4" HOMAPAL KICK (HOMAPAL 444N)
 CLEAR ALUMINUM BASE EXTRUSIONS
 1/4" ACRYLIC SCREENS (CLEAR FROSTED)

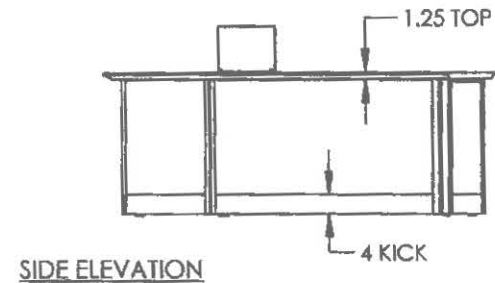
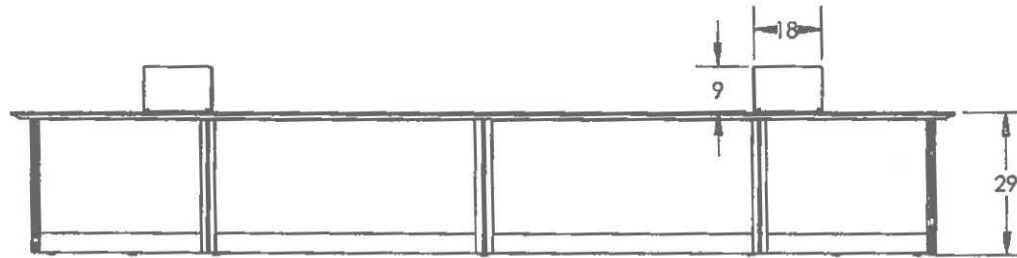
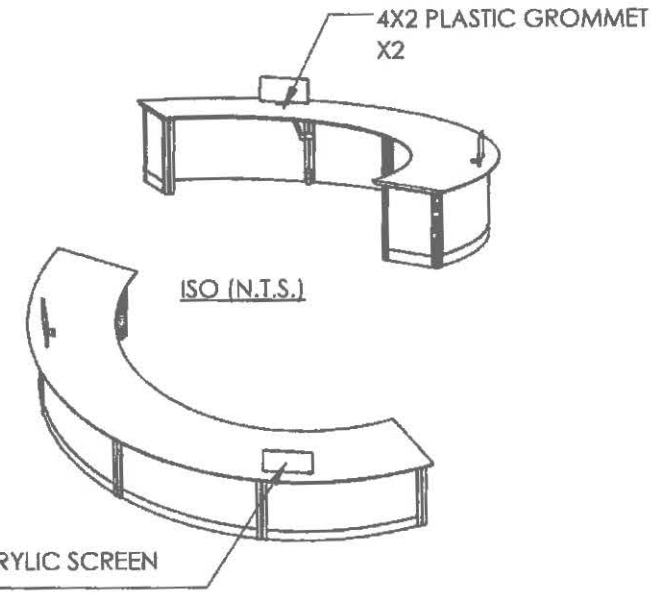
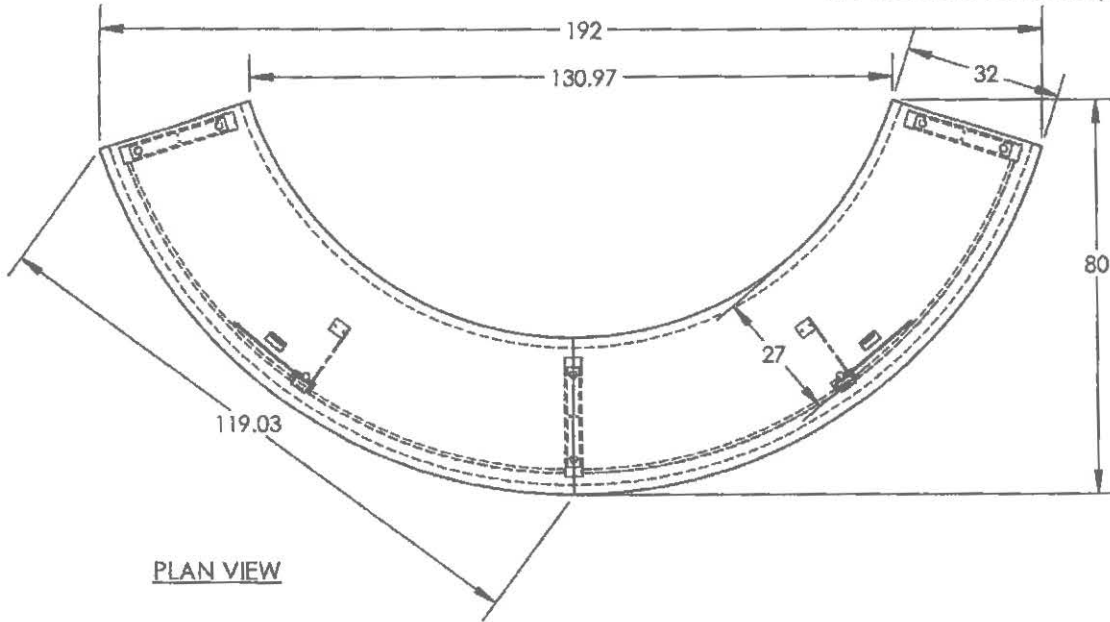

nienkämper 257 Finchdene Square, Scarborough, Ontario, Canada, M1X 1B9 Tel 416 298 8700 Fax 416 298 9535 www.nienkammer.com design@nienkammer.com	OC-Project: Q21-139	Title: BERWYN PUBLIC LIBRARY	Drawing No. Q21-139-03	Date: MAY 4, 2021	Issue Drawing To:
	THIS DRAWING IS CONFIDENTIAL AND PROPRIETARY. NO PART OF THIS DRAWING MAY BE COPIED, DISCLOSED TO ANY THIRD PARTY OR USED FOR ANY PURPOSE WITHOUT THE EXPRESS WRITTEN AUTHORIZATION OF NIENKAMPER FURNITURE & ACCESSORIES	Drawn: DT PART#: X.X	Scale: N.T.S CS. Rep: RS	Dwg For: CLIENT Rev Details: REV FINISHES	Rev Date: JUNE 28, 2021 / DT.

CS
 CUST SERV

VOX RECEPTION DESK

TAG : BERWYN PUBLIC LIBRARY
 CIRCULATION DESK 2, OPTION B
 QTY : 1 REQUIRED

FINISHES : P-LAM TOP (FORMICA CONCRETE FORMWOOD, 6362-NG)
 P-LAM MODESTIES AND BASE PANELS (FORMICA BASALT SLATE, 3690-34)
 4" HOMAPAL KICK (HOMAPAL 444N)
 CLEAR ALUMINUM BASE EXTRUSIONS
 1/4" ACRYLIC SCREENS (CLEAR FROSTED)

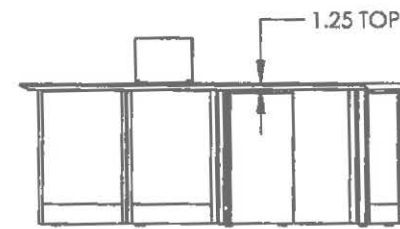
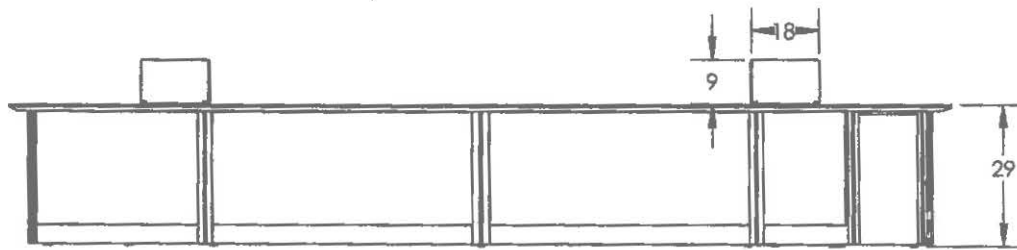
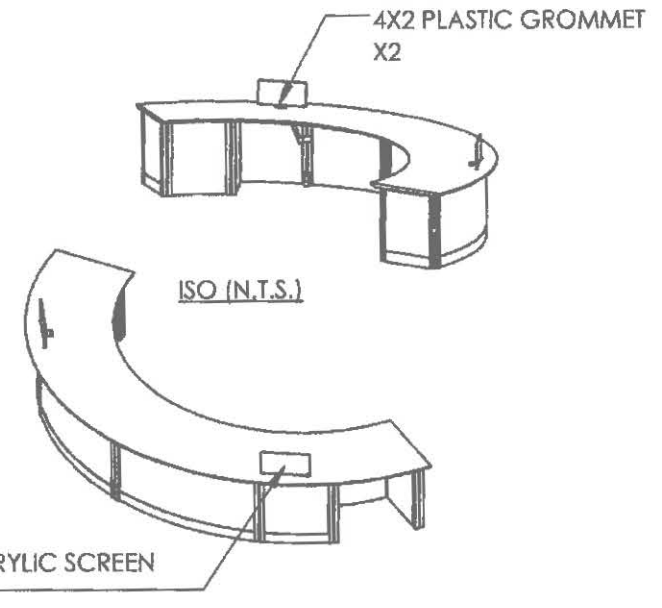
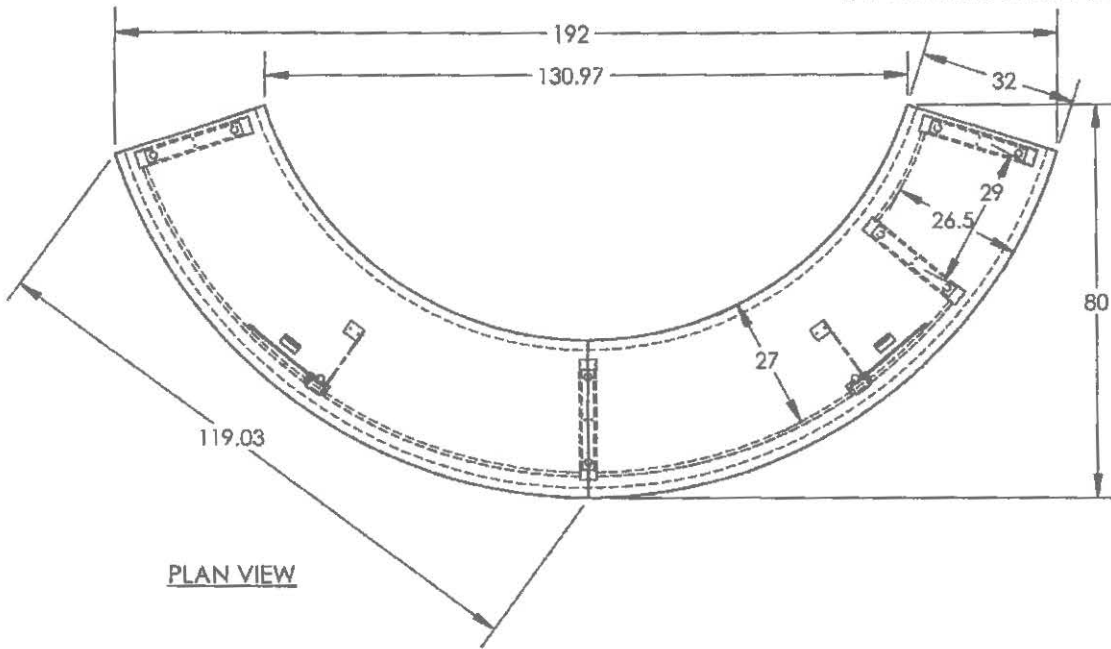

nienkämper 257 Finchdene Square, Scarborough, Ontario, Canada, M1X 1E9 Tel 416 298 6700 Fax 416 298 9636 www.nienkammer.com design@nienkammer.com	OC-Project: Q21-139	Title: BERWYN PUBLIC LIBRARY		Drawing No: Q21-139-04	Date: MAY 4, 2021	Issue Drawing To:	
	THIS DRAWING IS CONFIDENTIAL AND PROPRIETARY. NO PART OF THIS DRAWING MAY BE COPIED, DISCLOSED TO ANY THIRD PARTY OR USED FOR ANY PURPOSE WITHOUT THE EXPRESS WRITTEN AUTHORIZATION OF NIE NKÄMPE R FURNITURE & ACCESSORIES		Drawn: DT	Scale: N.T.S	Dwg For: CLIENT	Rev Date: JUNE 28, 2021 / DT	Revision No. R-2
PART#: X.X	CS. Rep: RS	Rev Details: REV FINISHES					

VOX RECEPTION DESK

TAG : BERWYN PUBLIC LIBRARY
 CIRCULATION DESK 3
 QTY : 1 REQUIRED

FINISHES : P-LAM TOP (FORMICA CONCRETE FORMWOOD, 6362-NG)
 P-LAM MODESTIES AND BASE PANELS (FORMICA BASALT SLATE, 3690-34)
 4" HOMAPAL KICK (HOMAPAL 444N)
 CLEAR ALUMINUM BASE EXTRUSIONS
 1/4" ACRYLIC SCREENS (CLEAR FROSTED)

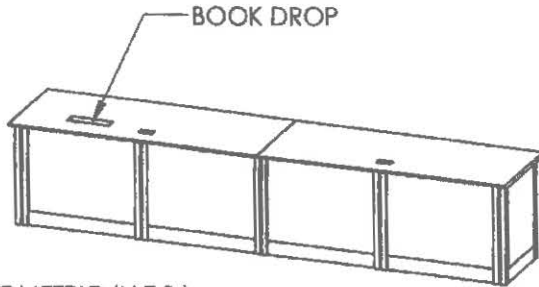

ISOMETRIC (N.T.S.)

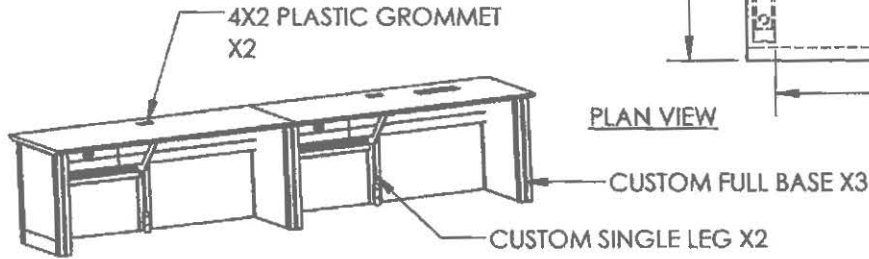

PLAN VIEW

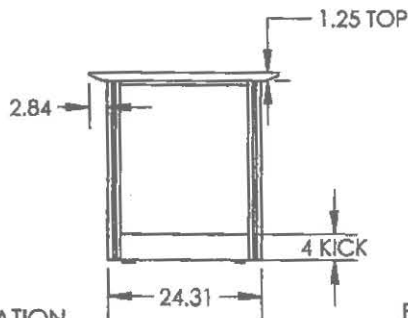
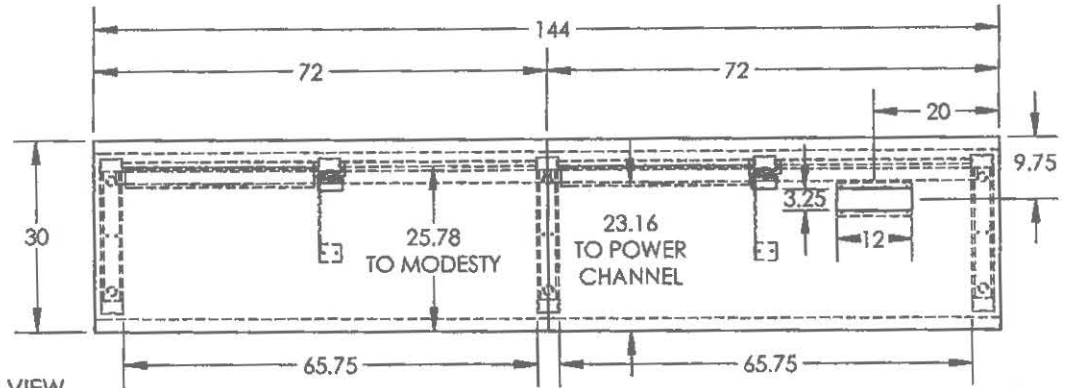

END ELEVATION

ELEVATION
USER SIDE

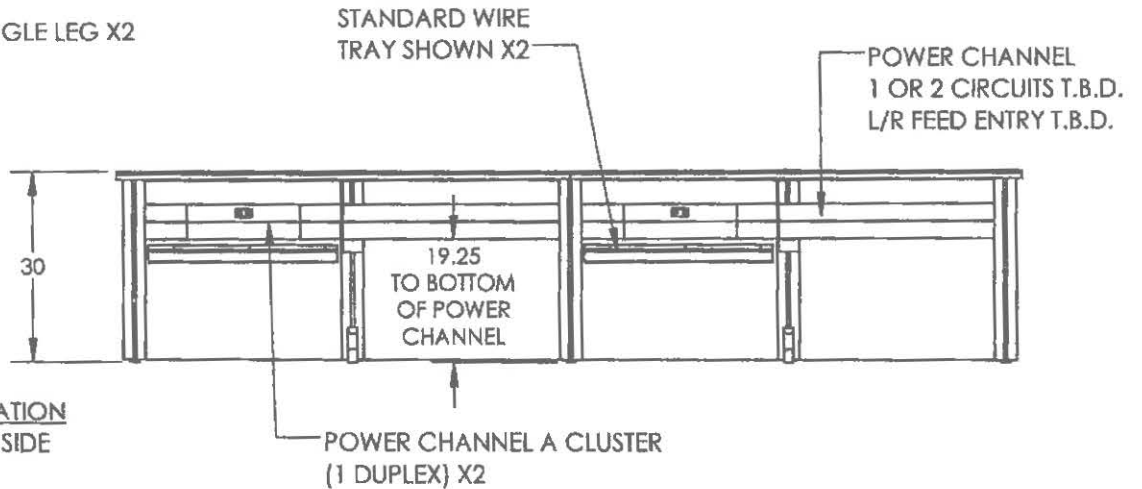

nienkämper 257 Finchdene Square, Scarborough, Ontario, Canada, M1X 1B9 Tel 416 296 6700 Fax 416 296 9536 www.nienkamper.com design@nienkamper.com	OC-Project: Q21-139	Title: BERWYN PUBLIC LIBRARY		Drawing No. Q21-139-05	Date: JUNE 21, 2021	Issue Drawing To:
	THIS DRAWING IS CONFIDENTIAL AND PROPRIETARY. NO PART OF THIS DRAWING MAY BE COPIED, DISCLOSED TO ANY THIRD PARTY OR USED FOR ANY PURPOSE WITHOUT THE EXPRESS WRITTEN AUTHORIZATION OF NIENKAMPER FURNITURE & ACCESSORIES		Drawn: DT	Scale: N.T.S	Dwg For: CLIENT	Rev Date: JUNE 28, 2021 / DT
		PART#: X.X	CS. Rep: RS	Rev Details: REV FINISHES REM ACRYLIC SCREENS		CS CUST SERV

nienkämper



Tag: VOX RECEPTION DESK - CIRCULATION DESK 2
OC / Quote: Q21-139
Client: BERWYN PUBLIC LIBRARY
Date: JUNE 28, 2021
Drawn By: DT

THIS DRAWING IS CONFIDENTIAL AND PROPRIETARY. NO PART OF THIS DRAWING MAY BE COPIED, DISCLOSED TO ANY THIRD PARTY OR USED FOR ANY PURPOSE, WITHOUT THE EXPRESS WRITTEN AUTHORIZATION OF NIENKAMPER FURNITURE & ACCESSORIES

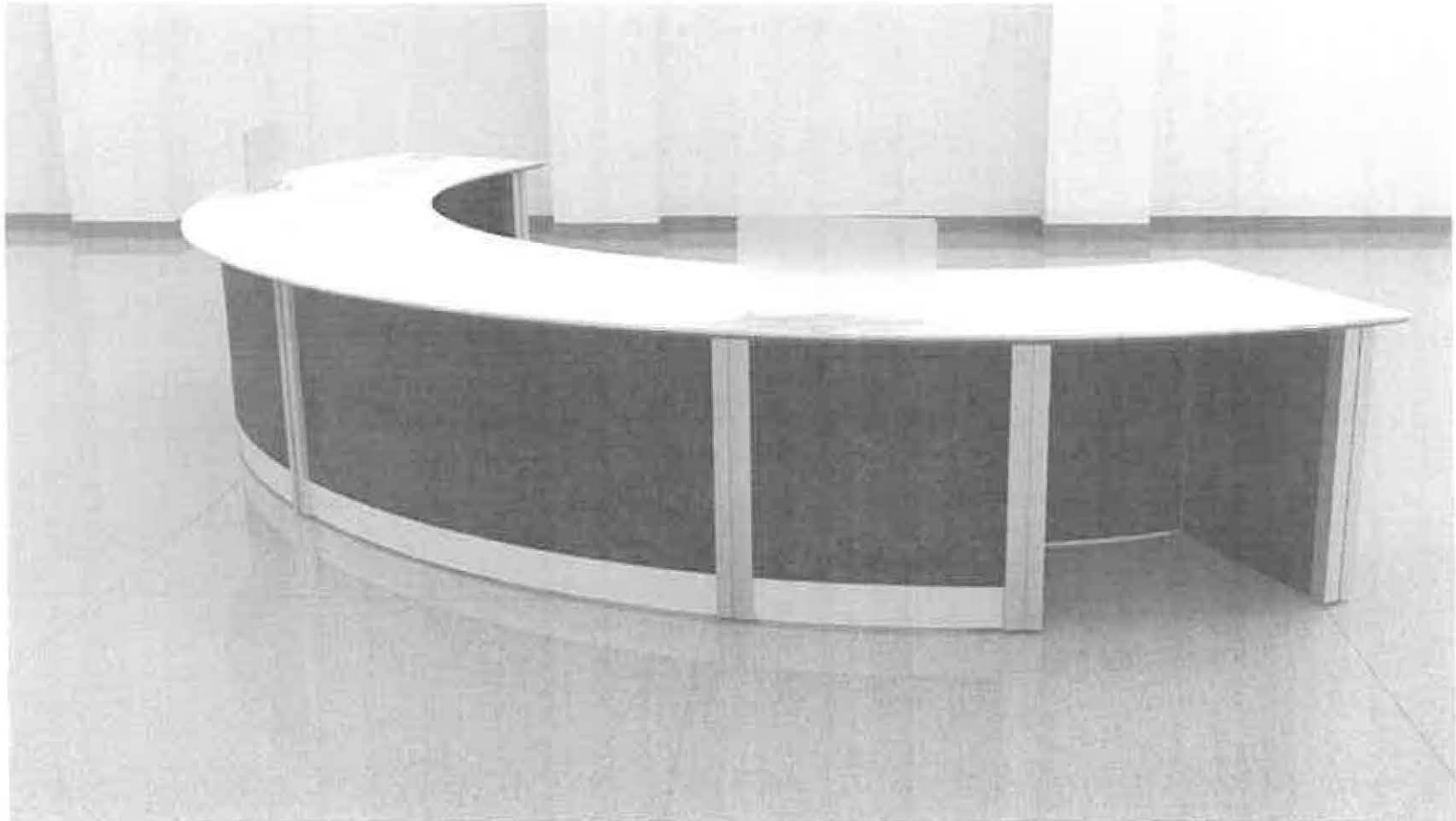

Tag: VOX RECEPTION DESK - CIRCULATION DESK 2
OC / Quote: Q21-139
Client: BERWYN PUBLIC LIBRARY
Date: JUNE 28, 2021
Drawn By: DT

THIS DRAWING IS CONFIDENTIAL AND PROPRIETARY. NO PART OF THIS DRAWING MAY BE COPIED, DISCLOSED TO ANY THIRD PARTY OR USED FOR ANY PURPOSE, WITHOUT THE EXPRESS WRITTEN AUTHORIZATION OF NIENKAMPER FURNITURE & ACCESSORIES

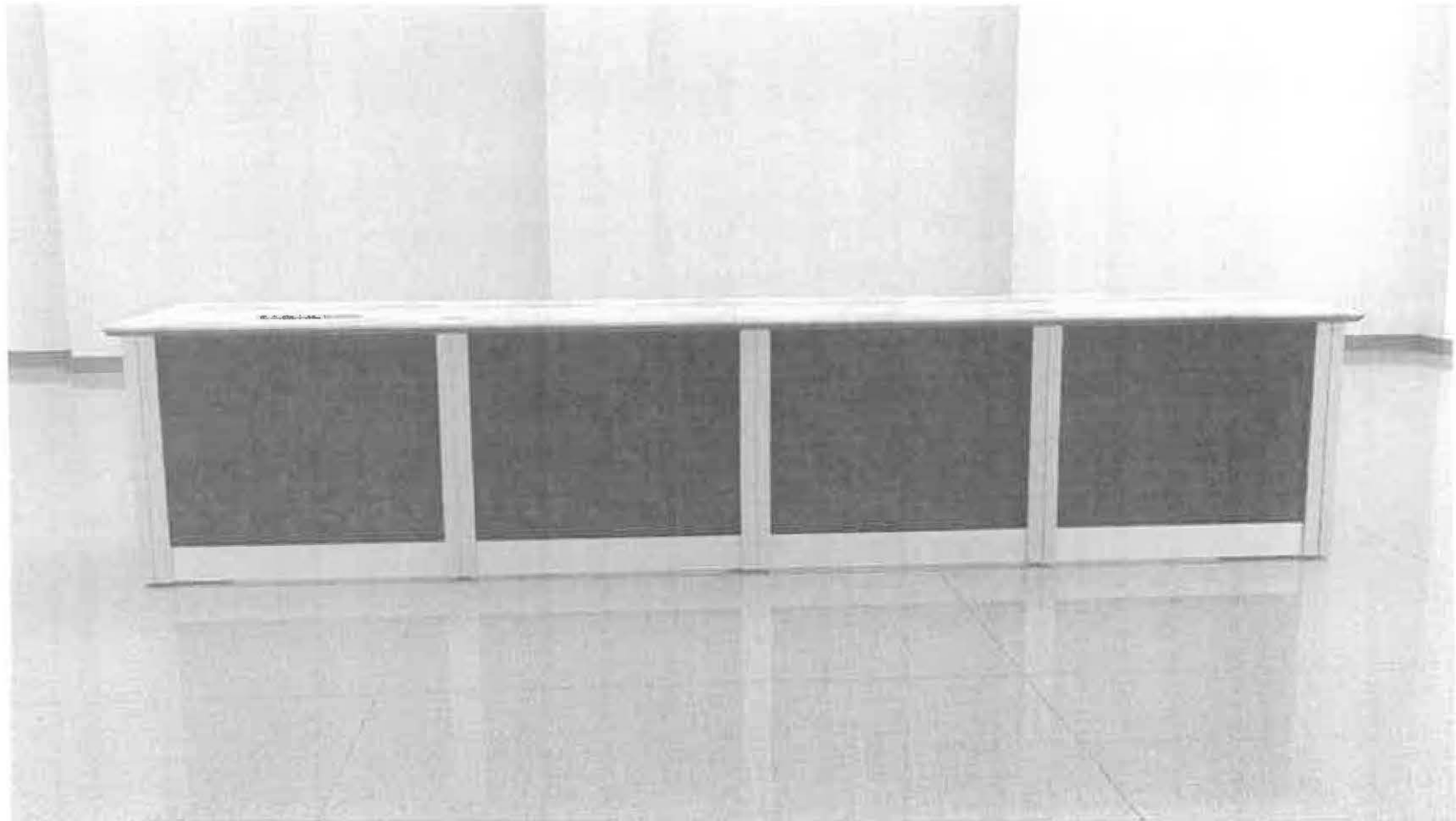

Tag: VOX RECEPTION DESK - CIRCULATION DESK 3
OC / Quote: Q21-139
Client: BERWYN PUBLIC LIBRARY
Date: JUNE 28, 2021
Drawn By: DT

THIS DRAWING IS CONFIDENTIAL AND PROPRIETARY. NO PART OF THIS DRAWING MAY BE
COPIED, DISCLOSED TO ANY THIRD PARTY OR USED FOR ANY PURPOSE, WITHOUT THE
EXPRESS WRITTEN AUTHORIZATION OF NIENKAMPER FURNITURE & ACCESSORIES

nienkämper

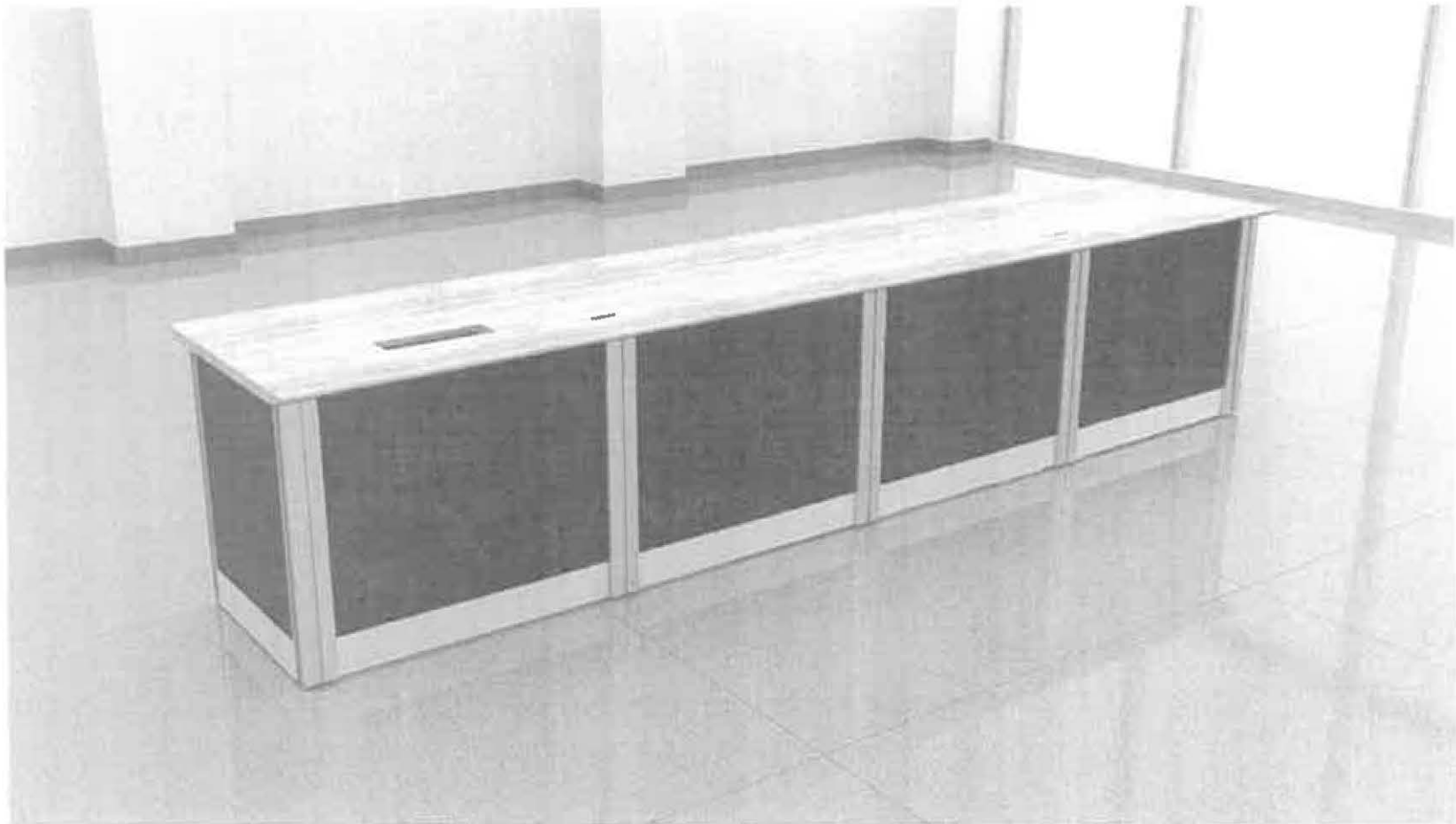

Tag: VOX RECEPTION DESK - CIRCULATION DESK 3
OC / Quote: Q21-139
Client: BERWYN PUBLIC LIBRARY
Date: JUNE 28, 2021
Drawn By: DT

THIS DRAWING IS CONFIDENTIAL AND PROPRIETARY. NO PART OF THIS DRAWING MAY BE COPIED, DISCLOSED TO ANY THIRD PARTY OR USED FOR ANY PURPOSE, WITHOUT THE EXPRESS WRITTEN AUTHORIZATION OF NIENKAMPER FURNITURE & ACCESSORIES

<u>BATCH</u>	<u>CK DATE</u>	<u>GROSS</u>	<u>FED</u>	<u>EMPLOYER FICA</u>	<u>EMPLOYER MEDICARE</u>	<u>STATE</u>
2202113	6/23/2021	1,334,200.55	150,360.75	28,855.54	18,255.86	55,244.68
FEDERAL	Federal	197,472.15				
STATE	State	55,244.68				

K-1

<u>BATCH</u>	<u>CK DATE</u>	<u>GROSS</u>	<u>FED</u>	<u>EMPLOYER FICA</u>	<u>EMPLOYER MEDICARE</u>	<u>STATE</u>
2202114	7/7/2021	1,278,943.93	137,221.71	30,312.44	17,535.10	52,884.19
FEDERAL	Federal	185,069.25				
STATE	State	52,884.19				

K-2



Accounts Payable by G/L Distribution Report

Payment Date Range 06/24/21 - 07/14/21

Vendor	Invoice No.	Invoice Description	Status	Held Reason	Invoice Date	Due Date	G/L Date	Received Date	Payment Date	Invoice Amount
Fund 100 - General Fund										
Department 02 - Mayor's Office										
Account 5200 - Administrative Expenses										
1922 - Berwyn North School District #98	2021-00000597	Game Sponsorship / Mayor Lovero	Paid by Check # 58636		06/23/2021	06/23/2021	06/23/2021		06/24/2021	250.00
4722 - MCAA Golf Outing	2021-00000576	Golf Outing Sponsorship/ Mayor Lovero	Paid by Check # 58651		06/23/2021	06/23/2021	06/23/2021		06/24/2021	200.00
							Account 5200 - Administrative Expenses Totals		Invoice Transactions 2	<u>\$450.00</u>
Account 5290 - Other General Expenses										
1810 - Robert J. Lovero	4204674594	Expense Reimbursement	Paid by Check # 58737		06/30/2021	06/30/2021	06/30/2021		06/30/2021	91.32
							Account 5290 - Other General Expenses Totals		Invoice Transactions 1	<u>\$91.32</u>
							Department 02 - Mayor's Office Totals		Invoice Transactions 3	<u>\$541.32</u>
Department 04 - City Clerk's Office										
Account 5225 - Supplies										
1764 - Margaret Paul	2021-00000678	Expense Reimbursement	Paid by Check # 58811		07/06/2021	07/06/2021	07/06/2021		07/14/2021	33.50
6242 - Salsbury Industries	1700931	Replacement Keys/Locks	Paid by Check # 58831		07/06/2021	07/06/2021	07/06/2021		07/14/2021	87.18
							Account 5225 - Supplies Totals		Invoice Transactions 2	<u>\$120.68</u>
Account 5615 - Record Retention										
3688 - American Mobile Shredding & Recycling, Inc.	2021-00000659	Document Destruction	Paid by Check # 58759		07/06/2021	07/06/2021	07/06/2021		07/14/2021	404.00
							Account 5615 - Record Retention Totals		Invoice Transactions 1	<u>\$404.00</u>
							Department 04 - City Clerk's Office Totals		Invoice Transactions 3	<u>\$524.68</u>
Department 06 - Treasurer's Office										
Account 5235 - Postage & Printing										
2705 - Lawndale News	833871	Annual Treasurer's Report	Paid by Check # 58730		06/29/2021	06/29/2021	06/29/2021		06/30/2021	3,000.00
							Account 5235 - Postage & Printing Totals		Invoice Transactions 1	<u>\$3,000.00</u>
							Department 06 - Treasurer's Office Totals		Invoice Transactions 1	<u>\$3,000.00</u>
Department 08 - City Council										
Account 5200-01 - Administrative Expenses Ward 1										
1922 - Berwyn North School District #98	2021-00000669	Alderman Donation / James Scott Lennon	Paid by Check # 58766		07/06/2021	07/06/2021	07/06/2021		07/14/2021	250.00
2081 - Friends of the Berwyn Public Library	2021-00000668	Membership Dues/ Alderman Scott Lennon	Paid by Check # 58794		07/06/2021	07/06/2021	07/06/2021		07/14/2021	100.00
							Account 5200-01 - Administrative Expenses Ward 1 Totals		Invoice Transactions 2	<u>\$350.00</u>
Account 5200-02 - Administrative Expenses Ward 2										
465 - Diamond Graphics, Inc.	0102830830	Business Cards	Paid by Check # 58719		06/29/2021	06/29/2021	06/29/2021		06/30/2021	80.00
							Account 5200-02 - Administrative Expenses Ward 2 Totals		Invoice Transactions 1	<u>\$80.00</u>



Accounts Payable by G/L Distribution Report

Payment Date Range 06/24/21 - 07/14/21

Vendor	Invoice No.	Invoice Description	Status	Held Reason	Invoice Date	Due Date	G/L Date	Received Date	Payment Date	Invoice Amount
Fund 100 - General Fund										
Department 08 - City Council										
Account 5200-03 - Administrative Expenses Ward 3										
465 - Diamond Graphics, Inc.	102830828	Business Cards / Richard Leja	Paid by Check # 58719		06/29/2021	06/29/2021	06/29/2021		06/30/2021	80.00
6238 - Richard E. Leja	2021-00000629	Expense Reimbursement	Paid by Check # 58736		06/29/2021	06/29/2021	06/29/2021		06/30/2021	638.00
6062 - St. Odilo School	2021-00000675	Sponsor / Alderman Richard Leja	Paid by Check # 58838		07/06/2021	07/06/2021	07/06/2021		07/14/2021	150.00
1922 - Berwyn North School District #98	2021-00000671	Alderman Donation / Richard Leja	Paid by Check # 58766		07/06/2021	07/06/2021	07/06/2021		07/14/2021	100.00
								Account 5200-03 - Administrative Expenses Ward 3 Totals	Invoice Transactions 4	\$968.00
Account 5200-07 - Administrative Expenses Ward 7										
1922 - Berwyn North School District #98	2021-00000619	Alderman Donation / Mary Beth Arenella	Paid by Check # 58711		06/29/2021	06/29/2021	06/29/2021		06/30/2021	200.00
180 - West Central Municipal Conference	2021-00000672	Golf Outing Sponsorship/ Alicia Ruiz & Mary Beth Arenella	Paid by Check # 58860		07/06/2021	07/06/2021	07/06/2021		07/14/2021	160.00
								Account 5200-07 - Administrative Expenses Ward 7 Totals	Invoice Transactions 2	\$360.00
								Department 08 - City Council Totals	Invoice Transactions 9	\$1,758.00
Department 10 - Legal										
Account 5110 - Adjudication Program										
5083 - Gary T. Copp	JUNE2021	Adjudication Hearings	Paid by Check # 58796		07/06/2021	07/06/2021	07/06/2021		07/14/2021	330.00
2077 - Patrick N. Murray	JUNE2021	Administrative Hearing Officer	Paid by Check # 58825		07/06/2021	07/06/2021	07/06/2021		07/14/2021	2,012.50
								Account 5110 - Adjudication Program Totals	Invoice Transactions 2	\$2,342.50
Account 5300 - Professional Services										
4501 - Klein, Thorpe and Jenkins, LTD.	218679	Legal Services Through May 2021	Paid by Check # 58728		06/30/2021	06/30/2021	06/30/2021		06/30/2021	857.50
4501 - Klein, Thorpe and Jenkins, LTD.	218680	Legal Services Through May 2021	Paid by Check # 58728		06/30/2021	06/30/2021	06/30/2021		06/30/2021	5,151.20
5601 - Servicios Fuentes LTD	JUNE2021	Legal Services June 2021	Paid by Check # 58836		07/06/2021	07/06/2021	07/06/2021		07/14/2021	825.00
2231 - Storino, Ramello & Durkin	82874	Legal Services Through Mar. 2021	Paid by Check # 58841		07/06/2021	07/06/2021	07/06/2021		07/14/2021	695.85
								Account 5300 - Professional Services Totals	Invoice Transactions 4	\$7,529.55
								Department 10 - Legal Totals	Invoice Transactions 6	\$9,872.05
Department 12 - Finance										
Sub Department 11 - Collector's Office										
Account 5300-04 - Professional Services Vehicle Registration										
608 - Scot Decal Company, Inc.	26399	Berwyn Visitor Parking Passes	Paid by Check # 58834		07/07/2021	07/07/2021	07/07/2021		07/14/2021	11,979.30



Accounts Payable by G/L Distribution Report

Payment Date Range 06/24/21 - 07/14/21

Vendor	Invoice No.	Invoice Description	Status	Held Reason	Invoice Date	Due Date	G/L Date	Received Date	Payment Date	Invoice Amount
Fund 100 - General Fund										
Department 12 - Finance										
Sub Department 11 - Collector's Office										
Account 5300-04 - Professional Services Vehicle Registration										
249 - Third Millennium Associates, Inc.	26426	Credit Card Transaction Fee	Paid by Check # 58849		07/07/2021	07/07/2021	07/07/2021		07/14/2021	1,569.00
							Account 5300-04 - Professional Services Vehicle Registration Totals		Invoice Transactions 2	<u>\$13,548.30</u>
							Sub Department 11 - Collector's Office Totals		Invoice Transactions 2	<u>\$13,548.30</u>
							Department 12 - Finance Totals		Invoice Transactions 2	<u>\$13,548.30</u>
Department 14 - Human Resources										
Account 5225-01 - Supplies Office										
465 - Diamond Graphics, Inc.	0102830809	White & Brown Kraft Envelopes	Paid by Check # 58719		06/30/2021	06/30/2021	06/30/2021		06/30/2021	424.00
							Account 5225-01 - Supplies Office Totals		Invoice Transactions 1	<u>\$424.00</u>
Account 5235 - Postage & Printing										
465 - Diamond Graphics, Inc.	0102830803	Grouplife Benefits Booklets	Paid by Check # 58719		06/30/2021	06/30/2021	06/30/2021		06/30/2021	645.00
							Account 5235 - Postage & Printing Totals		Invoice Transactions 1	<u>\$645.00</u>
							Department 14 - Human Resources Totals		Invoice Transactions 2	<u>\$1,069.00</u>
Department 16 - Information Technology										
Account 5290 - Other General Expenses										
1800 - CDW Government, Inc.	F405862	UPS Battery Replacement	Paid by Check # 58638		06/18/2021	06/18/2021	06/18/2021		06/24/2021	252.42
828 - SYNCB / AMAZON	767856576477	Open Invoices	Paid by Check # 58740		06/29/2021	06/29/2021	06/29/2021		06/30/2021	14.98
5820 - SYNCB / AMAZON	2021-00000670	IT office cleaning supplies/ micro DVI cables	Paid by Check # 58844		07/06/2021	07/06/2021	07/06/2021		07/14/2021	273.12
6126 - Verizon	9882776202	May 26 - June 25 2021	Paid by Check # 58856		07/06/2021	07/06/2021	07/06/2021		07/14/2021	579.97
1800 - CDW Government, Inc.	F989943	UPS Battery Replacement	Paid by Check # 58775		07/06/2021	07/06/2021	07/06/2021		07/14/2021	248.63
4951 - COTG	IN2803569	Printing fees/ flat JUL 2021	Paid by Check # 58782		07/06/2021	07/06/2021	07/06/2021		07/14/2021	1,811.76
4951 - COTG	IN2803567	Printing fees/ flat JUL 2021	Paid by Check # 58782		07/06/2021	07/06/2021	07/06/2021		07/14/2021	397.94
4033 - eDot	71231	Low voltage cabling / eDot CH Remodel	Paid by Check # 58789		07/06/2021	07/06/2021	07/06/2021		07/14/2021	4,419.00
4324 - CablesAndKits.com	522274	Patch Cables	Paid by Check # 58773		07/06/2021	07/06/2021	07/06/2021		07/14/2021	57.07
							Account 5290 - Other General Expenses Totals		Invoice Transactions 9	<u>\$8,054.89</u>



Accounts Payable by G/L Distribution Report

Payment Date Range 06/24/21 - 07/14/21

Vendor	Invoice No.	Invoice Description	Status	Held Reason	Invoice Date	Due Date	G/L Date	Received Date	Payment Date	Invoice Amount
Fund 100 - General Fund										
Department 16 - Information Technology										
Account 5410 - Hardware Maintenance										
4027 - AT&T	SB215642	PBX Maintenance agreement/annual, 2nd portion	Paid by Check # 58709		06/29/2021	06/29/2021	06/29/2021		06/30/2021	5,656.90
								Account 5410 - Hardware Maintenance Totals	Invoice Transactions 1	<u>\$5,656.90</u>
Account 5415 - Software Maintenance										
5052 - TKB Associates, Inc.	14332	Laserfiche annual maintenance 2021	Paid by Check # 58744		06/29/2021	06/29/2021	06/29/2021		06/30/2021	2,013.00
								Account 5415 - Software Maintenance Totals	Invoice Transactions 1	<u>\$2,013.00</u>
Account 5510 - Hardware Purchase										
1965 - Dell Marketing, LP	2021-00000599	PD 2nd floor Optiplex Investigations workstation	Paid by Check # 58665		06/24/2021	06/24/2021	06/24/2021		06/25/2021	1,249.58
5820 - SYNCB / AMAZON	938933778644 A95	Nortel 2033 IP Phones/Replm (2)	Paid by Check # 58741		06/29/2021	06/29/2021	06/29/2021		06/30/2021	170.00
								Account 5510 - Hardware Purchase Totals	Invoice Transactions 2	<u>\$1,419.58</u>
Account 5515 - Software Purchase										
1800 - CDW Government, Inc.	F379056	Adobe DC Cloud license (Suite Acrobat) for Fin Comm	Paid by Check # 58638		06/18/2021	06/18/2021	06/18/2021		06/24/2021	1,267.18
1800 - CDW Government, Inc.	F379344	Adobe DC Cloud license (Suite Acrobat) for Fin Comm	Paid by Check # 58638		06/18/2021	06/18/2021	06/18/2021		06/24/2021	403.15
								Account 5515 - Software Purchase Totals	Invoice Transactions 2	<u>\$1,670.33</u>
Account 5530 - Network Infrastructure										
4026 - AT&T	0210951605	AT&T 1G internet circuit/monthly	Paid by Check # 58634		06/18/2021	06/18/2021	06/18/2021		06/24/2021	4,256.00
4026 - AT&T	1557652609	ATT IP Flex/one month invoice	Paid by Check # 58634		06/18/2021	06/18/2021	06/18/2021		06/24/2021	1,561.20
4024 - AT & T	708788324806-6	AT&T POTS services/monthly	Paid by Check # 58666		06/25/2021	06/25/2021	06/25/2021		06/29/2021	49.44
4024 - AT & T	708788414806-6	AT&T POTS services/monthly	Paid by Check # 58666		06/25/2021	06/25/2021	06/25/2021		06/29/2021	49.44
5330 - AT&T Long Distance	834894336-23	Att Long Distance / June 2021	Paid by Check # 58667		06/25/2021	06/25/2021	06/25/2021		06/29/2021	81.34
4025 - AT&T	S667040040-21172	Monthly ASE connectivity fees/6 city locations	Paid by Check # 58763		07/06/2021	07/06/2021	07/06/2021		07/14/2021	6,946.04
								Account 5530 - Network Infrastructure Totals	Invoice Transactions 6	<u>\$12,943.46</u>
								Department 16 - Information Technology Totals	Invoice Transactions 21	<u>\$31,758.16</u>



Accounts Payable by G/L Distribution Report

Payment Date Range 06/24/21 - 07/14/21

Vendor	Invoice No.	Invoice Description	Status	Held Reason	Invoice Date	Due Date	G/L Date	Received Date	Payment Date	Invoice Amount	
Fund 100 - General Fund											
Department 17 - Administrative											
Account 5035-01 - Benefits Health Insurance											
15 - Health Care Service Corporation	2021-00000552	07/21 insurance premiums	Paid by Check # 58628		07/01/2021	07/01/2021	07/01/2021		07/01/2021	938,910.64	
6235 - VSP Vision Care of Illinois, NFP	2021-00000554	05/21 insurance premiums	Paid by Check # 58629		05/01/2021	07/01/2021	07/01/2021		07/01/2021	7,889.22	
6235 - VSP Vision Care of Illinois, NFP	2021-00000555	06/21 insurance premiums	Paid by Check # 58629		06/01/2021	07/01/2021	07/01/2021		07/01/2021	7,889.22	
6235 - VSP Vision Care of Illinois, NFP	2021-00000556	07/21 insurance premiums	Paid by Check # 58629		07/01/2021	07/01/2021	07/01/2021		07/01/2021	8,706.24	
									Account 5035-01 - Benefits Health Insurance Totals	Invoice Transactions 4	\$963,395.32
Account 5035-02 - Benefits Dental Insurance											
504 - AETNA	2021-00000550	07/21 insurance premiums	Paid by Check # 58626		07/01/2021	07/01/2021	07/01/2021		07/01/2021	37,896.30	
									Account 5035-02 - Benefits Dental Insurance Totals	Invoice Transactions 1	\$37,896.30
Account 5035-03 - Benefits Life Insurance											
16 - Dearborn National Life Insurance Company	2021-00000551	07/21 insurance premiums	Paid by Check # 58627		07/01/2021	07/01/2021	07/01/2021		07/01/2021	10,041.88	
									Account 5035-03 - Benefits Life Insurance Totals	Invoice Transactions 1	\$10,041.88
Account 5210 - Vehicle Gas & Oil											
1641 - Al Warren Oil Company	W1387429	Vehicle Gas & Oil May 2021	Paid by Check # 58757		07/07/2021	07/07/2021	07/07/2021		07/14/2021	5,163.18	
1641 - Al Warren Oil Company	W1389812	Vehicle Gas & Oil May 2021	Paid by Check # 58757		07/07/2021	07/07/2021	07/07/2021		07/14/2021	8,827.01	
1641 - Al Warren Oil Company	W1394262	Vehicle Gas & Oil June 2021	Paid by Check # 58757		07/07/2021	07/07/2021	07/07/2021		07/14/2021	9,119.38	
1641 - Al Warren Oil Company	W1394812	Vehicle Gas & Oil June 2021	Paid by Check # 58757		07/07/2021	07/07/2021	07/07/2021		07/14/2021	8,037.96	
1641 - Al Warren Oil Company	W1396326	Vehicle Gas & Oil June 2021	Paid by Check # 58757		07/07/2021	07/07/2021	07/07/2021		07/14/2021	5,963.12	
1641 - Al Warren Oil Company	W1397446	Vehicle Gas & Oil June 2021	Paid by Check # 58757		07/07/2021	07/07/2021	07/07/2021		07/14/2021	4,977.92	
1641 - Al Warren Oil Company	W1398247	Vehicle Gas & Oil June 2021	Paid by Check # 58757		07/07/2021	07/07/2021	07/07/2021		07/14/2021	300.00	
1641 - Al Warren Oil Company	W1398250	Vehicle Gas & Oil June 2021	Paid by Check # 58757		07/07/2021	07/07/2021	07/07/2021		07/14/2021	625.00	
1641 - Al Warren Oil Company	W1398464	Vehicle Gas & Oil June 2021	Paid by Check # 58757		07/07/2021	07/07/2021	07/07/2021		07/14/2021	8,361.20	
1641 - Al Warren Oil Company	W1399534	Vehicle Gas & Oil June 2021	Paid by Check # 58757		07/07/2021	07/07/2021	07/07/2021		07/14/2021	5,574.93	
1641 - Al Warren Oil Company	W1400561	Vehicle Gas & Oil July 2021	Paid by Check # 58757		07/07/2021	07/07/2021	07/07/2021		07/14/2021	7,666.15	
									Account 5210 - Vehicle Gas & Oil Totals	Invoice Transactions 11	\$64,615.85



Accounts Payable by G/L Distribution Report

Payment Date Range 06/24/21 - 07/14/21

Vendor	Invoice No.	Invoice Description	Status	Held Reason	Invoice Date	Due Date	G/L Date	Received Date	Payment Date	Invoice Amount
Fund 100 - General Fund										
Department 17 - Administrative										
Account 5290 - Other General Expenses										
180 - West Central Municipal Conference	0009875-IN	New Elected Official Workshop	Paid by Check # 58747		06/29/2021	06/29/2021	06/29/2021		06/30/2021	165.00
							Account 5290 - Other General Expenses Totals		Invoice Transactions 1	<u>\$165.00</u>
Account 5300-01 - Professional Services Auditing/Accounting										
5465 - Lauterbach & Amen, LLP	56376	Actuarial Report	Paid by Check # 58649		06/21/2021	06/21/2021	06/21/2021		06/24/2021	4,770.00
							Account 5300-01 - Professional Services Auditing/Accounting Totals		Invoice Transactions 1	<u>\$4,770.00</u>
							Department 17 - Administrative Totals		Invoice Transactions 19	<u>\$1,080,884.35</u>
Department 18 - Fire Department										
Account 5220 - Training, Dues & Publications										
6031 - Adrian Contreras	128904	Expense Reimbursement	Paid by Check # 58630		06/22/2021	06/22/2021	06/22/2021		06/24/2021	242.70
117 - Village of Romeoville Fire Academy	2021-261	Rope Ops for Overland and Hill Inv.# 2021-261	Paid by Check # 58661		06/22/2021	06/22/2021	06/22/2021		06/24/2021	1,350.00
117 - Village of Romeoville Fire Academy	2021-277	Vehicle & Machinery Tech Proce & Jacobs Inv. 2021-277	Paid by Check # 58661		06/22/2021	06/22/2021	06/22/2021		06/24/2021	1,700.00
117 - Village of Romeoville Fire Academy	2021-294	Training / Donald Quattrocchi	Paid by Check # 58661		06/22/2021	06/22/2021	06/22/2021		06/24/2021	525.00
117 - Village of Romeoville Fire Academy	2021-311	Eng. Co. Ops. Schlesinger-Gill-Kielbasa Invoice 2021-311	Paid by Check # 58746		06/29/2021	06/29/2021	06/29/2021		06/30/2021	1,500.00
							Account 5220 - Training, Dues & Publications Totals		Invoice Transactions 5	<u>\$5,317.70</u>
Account 5225 - Supplies										
1171 - US Gas	367676	Medical Compressed Oxygen Cylinders	Paid by Check # 58660		06/22/2021	06/22/2021	06/22/2021		06/24/2021	121.90
1171 - US Gas	371307	Medical Compressed Oxygen Cylinders Rental	Paid by Check # 58745		06/29/2021	06/29/2021	06/29/2021		06/30/2021	272.80
4907 - Building Services of America,LLC	71041	Fire Dept. Supplies	Paid by Check # 58714		06/29/2021	06/29/2021	06/29/2021		06/30/2021	453.72
1230 - Ecolab	6261954994	Enzymatic Laundry Soap	Paid by Check # 58720		06/29/2021	06/29/2021	06/29/2021		06/30/2021	586.62
1230 - Ecolab	62619549945	Fire Dept. Supplies	Paid by Check # 58720		06/29/2021	06/29/2021	06/29/2021		06/30/2021	694.17
							Account 5225 - Supplies Totals		Invoice Transactions 5	<u>\$2,129.21</u>
Account 5400 - Repairs & Maintenance										
162 - Jack's Rental, Inc.	84767	Chain Saw Repairs	Paid by Check # 58725		06/29/2021	06/29/2021	06/29/2021		06/30/2021	109.25



Accounts Payable by G/L Distribution Report

Payment Date Range 06/24/21 - 07/14/21

Vendor	Invoice No.	Invoice Description	Status	Held Reason	Invoice Date	Due Date	G/L Date	Received Date	Payment Date	Invoice Amount
Fund 100 - General Fund										
Department 18 - Fire Department										
Account 5400 - Repairs & Maintenance										
5981 - Crystal Maintenance Services	27605	Cleaning Services	Paid by Check # 58783		07/06/2021	07/06/2021	07/06/2021		07/14/2021	255.00
							Account 5400 - Repairs & Maintenance Totals		Invoice Transactions 2	\$364.25
Account 5400-30 - Repairs & Maintenance Building										
3418 - Hansen Door	10077	work done at all three Fire Stations Inv.'s 1007-10096-10097	Paid by Check # 58644		06/22/2021	06/22/2021	06/22/2021		06/24/2021	560.75
3418 - Hansen Door	10096	work done at all three Fire Stations Inv.'s 1007-10096-10097	Paid by Check # 58644		06/22/2021	06/22/2021	06/22/2021		06/24/2021	582.32
3418 - Hansen Door	10097	work done at all three Fire Stations Inv.'s 1007-10096-10097	Paid by Check # 58644		06/22/2021	06/22/2021	06/22/2021		06/24/2021	805.94
162 - Jack's Rental, Inc.	84718	rental protection	Paid by Check # 58646		06/22/2021	06/22/2021	06/22/2021		06/24/2021	432.00
3951 - Morning Noon & Night Plumbing	26960	Plumbing Services	Paid by Check # 58655		06/22/2021	06/22/2021	06/22/2021		06/24/2021	575.00
514 - Berwyn Western Plumbing & Heating	108645	Heating / Cooling Repairs	Paid by Check # 58712		06/29/2021	06/29/2021	06/29/2021		06/30/2021	525.00
1879 - Fox Valley Fire & Safety	IN00445723	Ansul Single Tank System Maintenance	Paid by Check # 58722		06/29/2021	06/29/2021	06/29/2021		06/30/2021	154.60
							Account 5400-30 - Repairs & Maintenance Building Totals		Invoice Transactions 7	\$3,635.61
Account 5400-31 - Repairs & Maintenance Fleet										
821 - Metro Collision Service / Metro Garage, Inc.	49116	Safety Inspections	Paid by Check # 58653		06/22/2021	06/22/2021	06/22/2021		06/24/2021	25.00
821 - Metro Collision Service / Metro Garage, Inc.	49121	Safety Inspections	Paid by Check # 58653		06/22/2021	06/22/2021	06/22/2021		06/24/2021	25.00
5104 - Bristol Hose & Fitting, Inc.	3459368	Hose ASSY	Paid by Check # 58713		06/29/2021	06/29/2021	06/29/2021		06/30/2021	254.49
5872 - Cummins Sales And Service	F2-81401	Major repairs to E902 Invoice F2-81401	Paid by Check # 58717		06/29/2021	06/29/2021	06/29/2021		06/30/2021	1,229.48
							Account 5400-31 - Repairs & Maintenance Fleet Totals		Invoice Transactions 4	\$1,533.97
Account 5500 - Equipment										
133 - MES - Illinois	IN1585884	Fire Dept Equipment	Paid by Check # 58652		06/22/2021	06/22/2021	06/22/2021		06/24/2021	836.26
							Account 5500 - Equipment Totals		Invoice Transactions 1	\$836.26
Account 5500-01 - Equipment Turnout Gear										
30099 - Ray O'Herron Company, Inc.	2120987-IN	20 - Black Ballistic Helmets	Paid by Check # 58656		06/22/2021	06/22/2021	06/22/2021		06/24/2021	5,200.00
							Account 5500-01 - Equipment Turnout Gear Totals		Invoice Transactions 1	\$5,200.00



Accounts Payable by G/L Distribution Report

Payment Date Range 06/24/21 - 07/14/21

Vendor	Invoice No.	Invoice Description	Status	Held Reason	Invoice Date	Due Date	G/L Date	Received Date	Payment Date	Invoice Amount
Fund 100 - General Fund										
Department 18 - Fire Department										
Account 5505 - Equipment Lease										
2458 - PNC Equipment Finance	1169297	Equipment Lease	Paid by Check # 58733		06/29/2021	06/29/2021	06/29/2021		06/30/2021	77,125.51
							Account 5505 - Equipment Lease Totals		Invoice Transactions 1	<u>\$77,125.51</u>
							Department 18 - Fire Department Totals		Invoice Transactions 26	<u>\$96,142.51</u>
Department 20 - Police Department										
Account 5040 - Tuition Reimbursement										
6143 - Benjamin Hernandez	L10942190-3	Tuition Reimbursement	Paid by Check # 58765		07/06/2021	07/06/2021	07/06/2021		07/14/2021	3,594.70
6173 - Joseph Meredith	12131790-1	Tuition Reimbursement	Paid by Check # 58807		07/06/2021	07/06/2021	07/06/2021		07/14/2021	1,247.79
6104 - Katie Perez	1215219031-3	Tuition Reimbursement	Paid by Check # 58809		07/06/2021	07/06/2021	07/06/2021		07/14/2021	1,660.78
							Account 5040 - Tuition Reimbursement Totals		Invoice Transactions 3	<u>\$6,503.27</u>
Account 5210 - Vehicle Gas & Oil										
5805 - Wex Bank	72593296	Vehicle Gas & Oil July 2021	Paid by Check # 58861		07/06/2021	07/06/2021	07/06/2021		07/14/2021	164.62
							Account 5210 - Vehicle Gas & Oil Totals		Invoice Transactions 1	<u>\$164.62</u>
Account 5215-01 - Telephone In-House										
4024 - AT & T	708795560106-3	May 14- June 13 2021	Paid by Check # 58708		06/29/2021	06/29/2021	06/29/2021		06/30/2021	268.56
478 - Comcast Cable	2021-00000662	Cable TV	Paid by Check # 58780		07/06/2021	07/06/2021	07/06/2021		07/14/2021	9.78
989 - T-Mobile	972823272-2	June 2021	Paid by Check # 58845		07/06/2021	07/06/2021	07/06/2021		07/14/2021	76.32
5703 - Technology Management Revolving Fund	T2130064	L.e.a.d.s. Lines	Paid by Check # 58846		07/06/2021	07/06/2021	07/06/2021		07/14/2021	942.40
							Account 5215-01 - Telephone In-House Totals		Invoice Transactions 4	<u>\$1,297.06</u>
Account 5220 - Training, Dues & Publications										
2490 - James McDonnell	598824A	Expense Reimbursement dues	Paid by Check # 58647		06/18/2021	06/18/2021	06/18/2021		06/24/2021	289.97
1976 - WESTAF	21-02	dues	Paid by Check # 58748		06/29/2021	06/29/2021	06/29/2021		06/30/2021	500.00
1976 - WESTAF	21-03	dues	Paid by Check # 58748		06/29/2021	06/29/2021	06/29/2021		06/30/2021	2,250.00
1144 - John E. Reid and Associates, Inc.	C384C56E-0003	Training / Katie Perez	Paid by Check # 58805		07/06/2021	07/06/2021	07/06/2021		07/14/2021	695.00
6237 - Macon County Law Enforcement Training Center	21-617	Training	Paid by Check # 58810		07/06/2021	07/06/2021	07/06/2021		07/14/2021	4,057.20
265 - Northeast Multi-Regional Training, Inc.	286613	Training / Katie Perez	Paid by Check # 58818		07/06/2021	07/06/2021	07/06/2021		07/14/2021	75.00



Accounts Payable by G/L Distribution Report

Payment Date Range 06/24/21 - 07/14/21

Vendor	Invoice No.	Invoice Description	Status	Held Reason	Invoice Date	Due Date	G/L Date	Received Date	Payment Date	Invoice Amount	
Fund 100 - General Fund											
Department 20 - Police Department											
Account 5220 - Training, Dues & Publications											
1931 - College of DuPage	1629600	Training / Phillip Quattrocchi	Paid by Check # 58778		07/06/2021	07/06/2021	07/06/2021		07/14/2021	325.00	
2456 - Health Endeavors, SC	8145	Training / Rickey Smith	Paid by Check # 58798		07/06/2021	07/06/2021	07/06/2021		07/14/2021	285.00	
									Account 5220 - Training, Dues & Publications Totals	Invoice Transactions 8	\$8,477.17
Account 5225-01 - Supplies Office											
2578 - Aqua Chill of Chicago LLC	2266443	Water Cooler Rentals	Paid by Check # 58761		07/06/2021	07/06/2021	07/06/2021		07/14/2021	177.00	
5669 - Garvey's Office Products	PINV2101759	P.D. Office Supplies	Paid by Check # 58795		07/06/2021	07/06/2021	07/06/2021		07/14/2021	135.60	
									Account 5225-01 - Supplies Office Totals	Invoice Transactions 2	\$312.60
Account 5235 - Postage & Printing											
4740 - HRdirect / gNeil	INV9891790	Local , Fed & State Posters-IL	Paid by Check # 58645		06/18/2021	06/18/2021	06/18/2021		06/24/2021	84.95	
465 - Diamond Graphics, Inc.	0102830913	form printing	Paid by Check # 58719		06/29/2021	06/29/2021	06/29/2021		06/30/2021	1,382.00	
465 - Diamond Graphics, Inc.	0102830892	Printing	Paid by Check # 58719		06/29/2021	06/29/2021	06/29/2021		06/30/2021	986.00	
365 - Amsterdam Printing & Litho Corporation	6860248	Printing	Paid by Check # 58760		07/06/2021	07/06/2021	07/06/2021		07/14/2021	398.23	
									Account 5235 - Postage & Printing Totals	Invoice Transactions 4	\$2,851.22
Account 5290 - Other General Expenses											
5850 - Angelina Manfredini	2021-00000546	Tobacco Special Agent	Paid by Check # 58632		06/18/2021	06/18/2021	06/18/2021		06/24/2021	50.00	
5849 - Giacomo Manfredini	2021-00000547	Tobacco Special Agent	Paid by Check # 58642		06/18/2021	06/18/2021	06/18/2021		06/24/2021	50.00	
JOSE LOPEZ	2021-00000598	SDI PARTY RENTAL	Paid by Check # 58664		06/24/2021	06/24/2021	06/24/2021		06/24/2021	120.00	
5482 - JG Uniforms	85431	Civilian Uniforms	Paid by Check # 58726		06/29/2021	06/29/2021	06/29/2021		06/30/2021	136.85	
783 - Special T Unlimited	37208	Civilian Uniforms	Paid by Check # 58738		06/29/2021	06/29/2021	06/29/2021		06/30/2021	1,954.00	
1609 - Card Imaging	122051	city ID cards	Paid by Check # 58716		06/29/2021	06/29/2021	06/29/2021		06/30/2021	4,140.00	
6240 - DBA Athletico Physical Therapy	17813	medical testing	Paid by Check # 58784		07/06/2021	07/06/2021	07/06/2021		07/14/2021	875.00	
6061 - Tribute Funeral Services	1514C	Removal & Morgue Transport	Paid by Check # 58853		07/06/2021	07/06/2021	07/06/2021		07/14/2021	415.00	
6061 - Tribute Funeral Services	1514E	Removal & Morgue Transport	Paid by Check # 58853		07/06/2021	07/06/2021	07/06/2021		07/14/2021	415.00	
6061 - Tribute Funeral Services	1514D	Removal & Morgue Transport	Paid by Check # 58853		07/06/2021	07/06/2021	07/06/2021		07/14/2021	415.00	



Accounts Payable by G/L Distribution Report

Payment Date Range 06/24/21 - 07/14/21

Vendor	Invoice No.	Invoice Description	Status	Held Reason	Invoice Date	Due Date	G/L Date	Received Date	Payment Date	Invoice Amount
Fund 100 - General Fund										
Department 20 - Police Department										
Account 5290 - Other General Expenses										
6061 - Tribute Funeral Services	1514A	Removal & Morgue Transport	Paid by Check # 58853		07/06/2021	07/06/2021	07/06/2021		07/14/2021	300.00
6061 - Tribute Funeral Services	1514B	Removal & Morgue Transport	Paid by Check # 58853		07/06/2021	07/06/2021	07/06/2021		07/14/2021	300.00
698 - Walgreens Company	500069292	Prisoner Medication	Paid by Check # 58858		07/06/2021	07/06/2021	07/06/2021		07/14/2021	166.28
5482 - JG Uniforms	85973	Civilian Uniforms	Paid by Check # 58803		07/06/2021	07/06/2021	07/06/2021		07/14/2021	138.95
5482 - JG Uniforms	86186	Body Armor	Paid by Check # 58803		07/06/2021	07/06/2021	07/06/2021		07/14/2021	715.00
5482 - JG Uniforms	86183	Body Armor	Paid by Check # 58803		07/06/2021	07/06/2021	07/06/2021		07/14/2021	145.00
1143 - Johnson, Roberts & Associates	146056	Background Checks	Paid by Check # 58806		07/06/2021	07/06/2021	07/06/2021		07/14/2021	17.50
6010 - Occupational Health Center at River Forest	6894	Drug Screens	Paid by Check # 58819		07/06/2021	07/06/2021	07/06/2021		07/14/2021	100.00
30099 - Ray O'Herron Company, Inc.	2124830-IN	Civilian Uniforms	Paid by Check # 58829		07/06/2021	07/06/2021	07/06/2021		07/14/2021	371.47
30099 - Ray O'Herron Company, Inc.	2124948-IN	Civilian Uniforms	Paid by Check # 58829		07/06/2021	07/06/2021	07/06/2021		07/14/2021	169.98
30617 - Sam's Club / Synchrony Bank	2021-00000665	Annual Membership Dues	Paid by Check # 58832		07/06/2021	07/06/2021	07/06/2021		07/14/2021	140.00
								Account 5290 - Other General Expenses Totals	Invoice Transactions 21	\$11,135.03
Account 5400-30 - Repairs & Maintenance Building										
4314 - Affordable Fire Protection, Inc.	5463-6	repairs to sprinkler	Paid by Check # 58707		06/29/2021	06/29/2021	06/29/2021		06/30/2021	2,882.00
492 - Fullmer Locksmith Service, Inc.	N28469	Single Cut Keys	Paid by Check # 58723		06/29/2021	06/29/2021	06/29/2021		06/30/2021	9.00
345 - Professional Pest Control, Inc.	JUNE2021	Exterminator Fee	Paid by Check # 58827		07/06/2021	07/06/2021	07/06/2021		07/14/2021	45.00
345 - Professional Pest Control, Inc.	JUNE2021-1	Exterminator Fee	Paid by Check # 58827		07/06/2021	07/06/2021	07/06/2021		07/14/2021	65.00
1387 - Secure Solutions, Inc.	14530	Key Keeper System Repair	Paid by Check # 58835		07/06/2021	07/06/2021	07/06/2021		07/14/2021	174.45
1387 - Secure Solutions, Inc.	13823	Key Keeper System Repair	Paid by Check # 58835		07/06/2021	07/06/2021	07/06/2021		07/14/2021	539.00
								Account 5400-30 - Repairs & Maintenance Building Totals	Invoice Transactions 6	\$3,714.45
Account 5400-31 - Repairs & Maintenance Fleet										
6071 - Car Reflections	21-141	Graphics	Paid by Check # 58715		06/29/2021	06/29/2021	06/29/2021		06/30/2021	115.00
32052 - Just Tires	332854	New Tires & Repairs	Paid by Check # 58727		06/29/2021	06/29/2021	06/29/2021		06/30/2021	163.50



Accounts Payable by G/L Distribution Report

Payment Date Range 06/24/21 - 07/14/21

Vendor	Invoice No.	Invoice Description	Status	Held Reason	Invoice Date	Due Date	G/L Date	Received Date	Payment Date	Invoice Amount	
Fund 100 - General Fund											
Department 20 - Police Department											
Account 5400-31 - Repairs & Maintenance Fleet											
32052 - Just Tires	333009	New Tires & Repairs	Paid by Check # 58727		06/29/2021	06/29/2021	06/29/2021		06/30/2021	708.88	
32052 - Just Tires	333074	New Tires & Repairs	Paid by Check # 58808		07/06/2021	07/06/2021	07/06/2021		07/14/2021	686.52	
32052 - Just Tires	333100	New Tires & Repairs	Paid by Check # 58808		07/06/2021	07/06/2021	07/06/2021		07/14/2021	401.76	
32052 - Just Tires	332770	New Tires & Repairs	Paid by Check # 58808		07/06/2021	07/06/2021	07/06/2021		07/14/2021	171.08	
32052 - Just Tires	333274	New Tires & Repairs	Paid by Check # 58808		07/06/2021	07/06/2021	07/06/2021		07/14/2021	365.91	
2673 - Deece Automotive	40670	Vehicle Repairs	Paid by Check # 58785		07/06/2021	07/06/2021	07/06/2021		07/14/2021	2,276.00	
6241 - Gas Plus Corporation DBA Buddy Bear Car Wash	138	155 Car Washes @ 3.00 ea	Paid by Check # 58797		07/06/2021	07/06/2021	07/06/2021		07/14/2021	465.00	
								Account 5400-31 - Repairs & Maintenance Fleet Totals		Invoice Transactions 9	<u>\$5,353.65</u>
Account 5415 - Software Maintenance											
5800 - Quicket Solutions	0000857	Quicket Software	Paid by Check # 58734		06/29/2021	06/29/2021	06/29/2021		06/30/2021	8,375.00	
5800 - Quicket Solutions	0000821	Quicket Software	Paid by Check # 58828		07/06/2021	07/06/2021	07/06/2021		07/14/2021	8,375.00	
								Account 5415 - Software Maintenance Totals		Invoice Transactions 2	<u>\$16,750.00</u>
Account 5500 - Equipment											
1965 - Dell Marketing, LP	10479121243	computer evidence storage	Paid by Check # 58718		06/29/2021	06/29/2021	06/29/2021		06/30/2021	1,249.68	
6228 - Amazon Capital Services	1VYM-PQMG- Y73R	Phone Cases	Paid by Check # 58758		07/06/2021	07/06/2021	07/06/2021		07/14/2021	218.35	
								Account 5500 - Equipment Totals		Invoice Transactions 2	<u>\$1,468.03</u>
Account 5800 - Capital Outlay											
5798 - Ori Brother's Flooring, Inc.	3065	carpet repairs	Paid by Check # 58820		07/06/2021	07/06/2021	07/06/2021		07/14/2021	3,000.00	
								Account 5800 - Capital Outlay Totals		Invoice Transactions 1	<u>\$3,000.00</u>
								Department 20 - Police Department Totals		Invoice Transactions 63	<u>\$61,027.10</u>
Department 22 - Fire & Police Commission											
Account 5290-11 - Other General Expenses Pre-Employment Physicals											
6060 - Edward R. Kirby & Associates	43468	Polygraph Exams & Background Checks	Paid by Check # 58721		06/29/2021	06/29/2021	06/29/2021		06/30/2021	1,319.40	
6010 - Occupational Health Center at River Forest	5119	Drug Screens	Paid by Check # 58731		06/29/2021	06/29/2021	06/29/2021		06/30/2021	1,690.00	
6010 - Occupational Health Center at River Forest	5039	Drug Screens	Paid by Check # 58731		06/29/2021	06/29/2021	06/29/2021		06/30/2021	895.00	
								Account 5290-11 - Other General Expenses Pre-Employment Physicals Totals		Invoice Transactions 3	<u>\$3,904.40</u>
								Department 22 - Fire & Police Commission Totals		Invoice Transactions 3	<u>\$3,904.40</u>



Accounts Payable by G/L Distribution Report

Payment Date Range 06/24/21 - 07/14/21

Vendor	Invoice No.	Invoice Description	Status	Held Reason	Invoice Date	Due Date	G/L Date	Received Date	Payment Date	Invoice Amount
Fund 100 - General Fund										
Department 24 - Building/Neighborhood Affairs										
Account 5300 - Professional Services										
294 - B. Davids Landscaping	2155	Lawncare & Misc. Services	Paid by Check # 58635		06/18/2021	06/18/2021	06/18/2021		06/24/2021	200.00
294 - B. Davids Landscaping	2154	Lawncare & Misc. Services	Paid by Check # 58635		06/18/2021	06/18/2021	06/18/2021		06/24/2021	200.00
3700 - EIS Elevator Inspection Services	101540	Elevator Inspections	Paid by Check # 58670		06/29/2021	06/29/2021	06/29/2021		06/29/2021	80.00
3700 - EIS Elevator Inspection Services	101010	Elevator Inspections	Paid by Check # 58670		06/29/2021	06/29/2021	06/29/2021		06/29/2021	80.00
1074 - K's Quality Construction, Inc.	21-305	Board Up & Misc Services	Paid by Check # 58673		06/29/2021	06/29/2021	06/29/2021		06/29/2021	345.00
1074 - K's Quality Construction, Inc.	21-306	Board Up & Misc Services	Paid by Check # 58673		06/29/2021	06/29/2021	06/29/2021		06/29/2021	315.00
1074 - K's Quality Construction, Inc.	21-307	Board Up & Misc Services	Paid by Check # 58673		06/29/2021	06/29/2021	06/29/2021		06/29/2021	470.00
1074 - K's Quality Construction, Inc.	21-308	Board Up & Misc Services	Paid by Check # 58673		06/29/2021	06/29/2021	06/29/2021		06/29/2021	2,509.00
1074 - K's Quality Construction, Inc.	21-309	Board Up & Misc Services	Paid by Check # 58673		06/29/2021	06/29/2021	06/29/2021		06/29/2021	345.00
1074 - K's Quality Construction, Inc.	21-310	Board Up & Misc Services	Paid by Check # 58673		06/29/2021	06/29/2021	06/29/2021		06/29/2021	315.00
3014 - JNC Consulting, Inc.	1326	Permit Inspections July 2021	Paid by Check # 58804		07/07/2021	07/07/2021	07/07/2021		07/14/2021	3,850.00
							Account 5300 - Professional Services Totals		Invoice Transactions 11	<u>\$8,709.00</u>
Account 5400 - Repairs & Maintenance										
1074 - K's Quality Construction, Inc.	21-2223	Pool Repairs	Paid by Check # 58673		06/29/2021	06/29/2021	06/29/2021		06/29/2021	9,400.00
5981 - Crystal Maintenance Services	27605	Cleaning Services	Paid by Check # 58783		07/06/2021	07/06/2021	07/06/2021		07/14/2021	1,439.16
							Account 5400 - Repairs & Maintenance Totals		Invoice Transactions 2	<u>\$10,839.16</u>
							Department 24 - Building/Neighborhood Affairs Totals		Invoice Transactions 13	<u>\$19,548.16</u>
Department 26 - Public Works										
Sub Department 35 - Streets										
Account 5225 - Supplies										
299 - Sherwin Williams Company	5191-5	yellowtraffic paint	Paid by Check # 58657		06/18/2021	06/18/2021	06/18/2021		06/24/2021	1,249.50
							Account 5225 - Supplies Totals		Invoice Transactions 1	<u>\$1,249.50</u>
Account 5300 - Professional Services										
1103 - Lyons Tree Service, Inc.	206-A	tree trimming /removal	Paid by Check # 58650		06/18/2021	06/18/2021	06/18/2021		06/24/2021	9,320.00
							Account 5300 - Professional Services Totals		Invoice Transactions 1	<u>\$9,320.00</u>



Accounts Payable by G/L Distribution Report

Payment Date Range 06/24/21 - 07/14/21

Vendor	Invoice No.	Invoice Description	Status	Held Reason	Invoice Date	Due Date	G/L Date	Received Date	Payment Date	Invoice Amount
Fund 100 - General Fund										
Department 26 - Public Works										
Sub Department 35 - Streets										
Account 5400 - Repairs & Maintenance										
5684 - Dupage Materials Company, LLC	14026	asphalt	Paid by Check # 58639		06/18/2021	06/18/2021	06/18/2021		06/24/2021	123.74
2884 - K-Five Hodgkins LLC	30764	asphalt	Paid by Check # 58648		06/18/2021	06/18/2021	06/18/2021		06/24/2021	553.52
4902 - Ozinga Ready Mix Concrete Inc.	ARI00066423	concrete	Paid by Check # 58822		07/07/2021	07/07/2021	07/07/2021		07/14/2021	1,569.38
4902 - Ozinga Ready Mix Concrete Inc.	ARI00103950	concrete	Paid by Check # 58822		07/07/2021	07/07/2021	07/07/2021		07/14/2021	1,291.50
1387 - Secure Solutions, Inc.	13130	key box repair	Paid by Check # 58835		07/07/2021	07/07/2021	07/07/2021		07/14/2021	598.90
1387 - Secure Solutions, Inc.	13142	key box repair	Paid by Check # 58835		07/07/2021	07/07/2021	07/07/2021		07/14/2021	384.90
1387 - Secure Solutions, Inc.	14185	key box repair	Paid by Check # 58835		07/07/2021	07/07/2021	07/07/2021		07/14/2021	987.90
1893 - Suburban Tree Consortium	0007104-IN	bi-yearly tree planting	Paid by Check # 58843		07/07/2021	07/07/2021	07/07/2021		07/14/2021	11,125.00
5981 - Crystal Maintenance Services	27605	Cleaning Services	Paid by Check # 58783		07/06/2021	07/06/2021	07/06/2021		07/14/2021	345.82
							Account 5400 - Repairs & Maintenance Totals		Invoice Transactions 9	<u>\$16,980.66</u>
							Sub Department 35 - Streets Totals		Invoice Transactions 11	<u>\$27,550.16</u>
Sub Department 37 - Fleet										
Account 5225 - Supplies										
1000 - Standard Equipment Company	P29645	fleet supplies	Paid by Check # 58658		06/18/2021	06/18/2021	06/18/2021		06/24/2021	870.46
5831 - Zeigler Ford North Riverside	525578	vehide parts	Paid by Check # 58662		06/18/2021	06/18/2021	06/18/2021		06/24/2021	477.71
5831 - Zeigler Ford North Riverside	525617	vehide parts	Paid by Check # 58662		06/18/2021	06/18/2021	06/18/2021		06/24/2021	920.15
5831 - Zeigler Ford North Riverside	672495	vehide parts	Paid by Check # 58662		06/18/2021	06/18/2021	06/18/2021		06/24/2021	380.00
1000 - Standard Equipment Company	P29909	fleet supplies	Paid by Check # 58839		07/07/2021	07/07/2021	07/07/2021		07/14/2021	1,819.87
5046 - Metal Supermarkets	1025268	Maintenance Supplies	Paid by Check # 58815		07/07/2021	07/07/2021	07/07/2021		07/14/2021	59.42
5104 - Bristol Hose & Fitting, Inc.	3460197	hoses	Paid by Check # 58772		07/07/2021	07/07/2021	07/07/2021		07/14/2021	40.91
							Account 5225 - Supplies Totals		Invoice Transactions 7	<u>\$4,568.52</u>
Account 5300 - Professional Services										
5645 - Stevenson Crane Services, Inc.	224702	service	Paid by Check # 58840		07/07/2021	07/07/2021	07/07/2021		07/14/2021	7,167.44



Accounts Payable by G/L Distribution Report

Payment Date Range 06/24/21 - 07/14/21

Vendor	Invoice No.	Invoice Description	Status	Held Reason	Invoice Date	Due Date	G/L Date	Received Date	Payment Date	Invoice Amount
Fund 100 - General Fund										
Department 26 - Public Works										
Sub Department 37 - Fleet										
Account 5300 - Professional Services										
5645 - Stevenson Crane Services, Inc.	224909	vechile repair	Paid by Check # 58840		07/07/2021	07/07/2021	07/07/2021		07/14/2021	2,193.00
							Account 5300 - Professional Services Totals		Invoice Transactions 2	<u>\$9,360.44</u>
							Sub Department 37 - Fleet Totals		Invoice Transactions 9	<u>\$13,928.96</u>
							Department 26 - Public Works Totals		Invoice Transactions 20	<u>\$41,479.12</u>
Department 32 - Recreation										
Account 5100 - Special Events										
30617 - Sam's Club / Synchrony Bank	2021-00000602	Day Camp Snacks & Misc. Supplies	Paid by Check # 58678		06/25/2021	06/25/2021	06/25/2021		06/29/2021	130.07
CHICAGO DOGS BASEBALL	2021-00000603	Day Camp Field Trip to Chicago Dogs Baseball	Paid by Check # 58684		06/25/2021	06/25/2021	06/25/2021		06/29/2021	1,165.00
2822 - Lakeview Bus Lines, Inc.	67515	Bus For Day Camp Field Trip to Lake Theatre	Paid by Check # 58674		06/25/2021	06/25/2021	06/25/2021		06/29/2021	195.00
2822 - Lakeview Bus Lines, Inc.	1263216	Bus For Day Camp Field Trip to Lake Theatre	Paid by Check # 58729		06/30/2021	06/30/2021	06/30/2021		06/30/2021	252.00
309 - Melrose Pyrotechnics, Inc.	22657-1	Fireworks Display	Paid by Check # 58812		07/06/2021	07/06/2021	07/06/2021		07/14/2021	2,000.00
							Account 5100 - Special Events Totals		Invoice Transactions 5	<u>\$3,742.07</u>
Account 5215 - Telephone										
4024 - AT & T	708788155006-4	May 17- June 16 2021	Paid by Check # 58762		07/06/2021	07/06/2021	07/06/2021		07/14/2021	31.63
4024 - AT & T	708788233406-3	May 17- June 16 2021	Paid by Check # 58762		07/06/2021	07/06/2021	07/06/2021		07/14/2021	31.63
4024 - AT & T	708788265706-4	May 17- June 16 2021	Paid by Check # 58762		07/06/2021	07/06/2021	07/06/2021		07/14/2021	346.30
							Account 5215 - Telephone Totals		Invoice Transactions 3	<u>\$409.56</u>
Account 5225-02 - Supplies Program										
1013 - Horizon Screen Print	21-2779	Baseball Shirts	Paid by Check # 58671		06/25/2021	06/25/2021	06/25/2021		06/29/2021	1,238.00
1013 - Horizon Screen Print	21-2777	Baseball Shirts	Paid by Check # 58671		06/25/2021	06/25/2021	06/25/2021		06/29/2021	1,501.75
1013 - Horizon Screen Print	21-2778	Baseball Shirts	Paid by Check # 58671		06/25/2021	06/25/2021	06/25/2021		06/29/2021	1,509.50
32703 - Personalized Awards	21-1277	Baseball Awards	Paid by Check # 58677		06/25/2021	06/25/2021	06/25/2021		06/29/2021	2,636.00
415 - Santo Sport Store	706605	16 in Softballs	Paid by Check # 58679		06/25/2021	06/25/2021	06/25/2021		06/29/2021	396.00



Accounts Payable by G/L Distribution Report

Payment Date Range 06/24/21 - 07/14/21

Vendor	Invoice No.	Invoice Description	Status	Held Reason	Invoice Date	Due Date	G/L Date	Received Date	Payment Date	Invoice Amount	
Fund 100 - General Fund											
Department 32 - Recreation											
Account 5225-02 - Supplies Program											
ARLINGTON HEIGHTS YOUTH ATHLETIC ASSOCIATION	2021-00000630	Baseball Tournament Fees	Paid by Check # 58750		06/30/2021	06/30/2021	06/30/2021		06/30/2021	450.00	
DES PLAINES PARK DISTRICT	48221	Day Camp Field Trip	Paid by Check # 58754		07/06/2021	07/06/2021	07/06/2021		07/07/2021	1,138.00	
TNT SPORTS GROUP	2021-00000676	Baseball Tournament Fees	Paid by Check # 58755		07/07/2021	07/07/2021	07/07/2021		07/07/2021	450.00	
415 - Santo Sport Store	706636	16 in. Softballs	Paid by Check # 58833		07/06/2021	07/06/2021	07/06/2021		07/14/2021	396.00	
2731 - The Lifeguard Store, Inc.	ORD000968912	Misc. Pool / Lifeguard Supplies	Paid by Check # 58848		07/06/2021	07/06/2021	07/06/2021		07/14/2021	1,697.50	
									Account 5225-02 - Supplies Program Totals	Invoice Transactions 10	\$11,412.75
Account 5290 - Other General Expenses											
1692 - M. K. Sports	JUNE2021-1	Umpires for Adult Soft Ball	Paid by Check # 58675		06/25/2021	06/25/2021	06/25/2021		06/29/2021	2,356.00	
1692 - M. K. Sports	2021-00000661	T-Ball Coordinator Fee	Paid by Check # 58753		07/06/2021	07/06/2021	07/06/2021		07/07/2021	2,400.00	
75 - Empire Cooler Service, Inc.	0000421987	Ice Machine Rental	Paid by Check # 58792		07/06/2021	07/06/2021	07/06/2021		07/14/2021	92.00	
									Account 5290 - Other General Expenses Totals	Invoice Transactions 3	\$4,848.00
Account 5400 - Repairs & Maintenance											
514 - Berwyn Western Plumbing & Heating	2021-00000596	Pool Repairs	Paid by Check # 58637		06/24/2021	06/24/2021	06/24/2021		06/24/2021	7,800.00	
342 - Elite Construction Solutions, Inc.	2021-425	Pool Repairs	Paid by Check # 58640		06/24/2021	06/24/2021	06/24/2021		06/24/2021	1,960.00	
342 - Elite Construction Solutions, Inc.	2021-423	Painting Locker Rooms	Paid by Check # 58640		06/24/2021	06/24/2021	06/24/2021		06/24/2021	2,500.00	
2364 - Metro Motors	OTM037175	Golf Cart Repairs	Paid by Check # 58654		06/24/2021	06/24/2021	06/24/2021		06/24/2021	367.87	
162 - Jack's Rental, Inc.	84746	Rec Building Supplies	Paid by Check # 58672		06/25/2021	06/25/2021	06/25/2021		06/29/2021	24.00	
162 - Jack's Rental, Inc.	84682	Rec Building Supplies	Paid by Check # 58672		06/25/2021	06/25/2021	06/25/2021		06/29/2021	93.98	
5426 - Menards	61235	Rec Building Supplies	Paid by Check # 58676		06/25/2021	06/25/2021	06/25/2021		06/29/2021	70.86	
5418 - Cintas Corporation	4087656891	Rec Building Supplies	Paid by Check # 58669		06/25/2021	06/25/2021	06/25/2021		06/29/2021	418.30	
514 - Berwyn Western Plumbing & Heating	62167	Baseball Alley Dewinterization	Paid by Check # 58668		06/25/2021	06/25/2021	06/25/2021		06/29/2021	1,796.40	
1074 - K's Quality Construction, Inc.	21-2222	Pool Repairs	Paid by Check # 58673		06/29/2021	06/29/2021	06/29/2021		06/29/2021	59,500.00	
514 - Berwyn Western Plumbing & Heating	62188	Repairs To Locker Rooms	Paid by Check # 58767		07/06/2021	07/06/2021	07/06/2021		07/14/2021	3,128.40	



Accounts Payable by G/L Distribution Report

Payment Date Range 06/24/21 - 07/14/21

Vendor	Invoice No.	Invoice Description	Status	Held Reason	Invoice Date	Due Date	G/L Date	Received Date	Payment Date	Invoice Amount
Fund 100 - General Fund										
Department 32 - Recreation										
Account 5400 - Repairs & Maintenance										
478 - Comcast Cable	2021-00000660	Rec Cable	Paid by Check # 58780		07/06/2021	07/06/2021	07/06/2021		07/14/2021	12.38
342 - Elite Construction Solutions, Inc.	2021-426	Pool Repairs	Paid by Check # 58791		07/06/2021	07/06/2021	07/06/2021		07/14/2021	3,550.00
5426 - Menards	61693	Maintenance Supplies	Paid by Check # 58814		07/06/2021	07/06/2021	07/06/2021		07/14/2021	20.49
5426 - Menards	61236	Battery Recycling Credit	Paid by Check # 58813		06/25/2021	06/25/2021	06/25/2021		07/14/2021	(10.00)
5123 - Nationwide Transmission & Complete Auto Service	F530TRAIL	Vehicle Repairs	Paid by Check # 58817		07/06/2021	07/06/2021	07/06/2021		07/14/2021	117.75
510 - Sportsfields, Inc.	2021004.8	Duraplay #40LBS & Delivery	Paid by Check # 58837		07/06/2021	07/06/2021	07/06/2021		07/14/2021	980.00
391 - Tele-Tron Ace Hardware	93154	Maintenance Supplies	Paid by Check # 58847		07/06/2021	07/06/2021	07/06/2021		07/14/2021	766.38
6239 - Tim's Glass & Mirror	1009444	Glass Door Repair	Paid by Check # 58850		07/06/2021	07/06/2021	07/06/2021		07/14/2021	505.99
5981 - Crystal Maintenance Services	27605	Cleaning Services	Paid by Check # 58783		07/06/2021	07/06/2021	07/06/2021		07/14/2021	81.66
							Account 5400 - Repairs & Maintenance Totals		Invoice Transactions 20	<u>\$83,684.46</u>
							Department 32 - Recreation Totals		Invoice Transactions 41	<u>\$104,096.84</u>
Department 46 - Senior Citizen Program										
Account 5215 - Telephone										
6126 - Verizon	9882776205	May 26 - June 25 2021	Paid by Check # 58856		07/08/2021	07/08/2021	07/08/2021		07/14/2021	309.65
							Account 5215 - Telephone Totals		Invoice Transactions 1	<u>\$309.65</u>
Account 5300 - Professional Services										
6010 - Occupational Health Center at River Forest	6949	DOT Physical & Drug Screen / Maria Fernandez	Paid by Check # 58819		07/08/2021	07/08/2021	07/08/2021		07/14/2021	290.00
							Account 5300 - Professional Services Totals		Invoice Transactions 1	<u>\$290.00</u>
Account 5400 - Repairs & Maintenance										
6219 - Edgar Silva	2021-00000677	Senior Handyman	Paid by Check # 58788		07/08/2021	07/08/2021	07/08/2021		07/14/2021	615.00
							Account 5400 - Repairs & Maintenance Totals		Invoice Transactions 1	<u>\$615.00</u>
Account 5400-04 - Repairs & Maintenance Landscape										
JASON VON ROTHE	2021-00000549	REFUND SENIOR LAWN CARE	Paid by Check # 58663		06/21/2021	06/21/2021	06/21/2021		06/24/2021	60.00
2932 - Richard C. Dahms	JUNE2021-3	Senior Lawncare	Paid by Check # 58830		07/08/2021	07/08/2021	07/08/2021		07/14/2021	1,080.00
294 - B. Davids Landscaping	JUNE2021-2	Senior Lawncare	Paid by Check # 58764		07/08/2021	07/08/2021	07/08/2021		07/14/2021	1,455.00



Accounts Payable by G/L Distribution Report

Payment Date Range 06/24/21 - 07/14/21

Vendor	Invoice No.	Invoice Description	Status	Held Reason	Invoice Date	Due Date	G/L Date	Received Date	Payment Date	Invoice Amount
Fund 100 - General Fund										
Department 46 - Senior Citizen Program										
Account 5400-04 - Repairs & Maintenance Landscape										
294 - B. Davids Landscaping	JULY2021	Senior Lawncare	Paid by Check # 58764		07/08/2021	07/08/2021	07/08/2021		07/14/2021	1,440.00
5425 - Blades of Glory, Inc.	3-6	Senior Lawncare	Paid by Check # 58771		07/08/2021	07/08/2021	07/08/2021		07/14/2021	1,455.00
5425 - Blades of Glory, Inc.	4-9	Senior Lawncare	Paid by Check # 58771		07/08/2021	07/08/2021	07/08/2021		07/14/2021	1,425.00
Account 5400-04 - Repairs & Maintenance Landscape Totals								Invoice Transactions	6	<u>\$6,915.00</u>
Account 5505 - Equipment Lease										
96 - PACE Suburban Bus	592536	1 Van @ 100 each	Paid by Check # 58823		07/08/2021	07/08/2021	07/08/2021		07/14/2021	100.00
96 - PACE Suburban Bus	592537	1 Van @100 each	Paid by Check # 58823		07/08/2021	07/08/2021	07/08/2021		07/14/2021	100.00
96 - PACE Suburban Bus	592538	1 Van @100 each	Paid by Check # 58823		07/08/2021	07/08/2021	07/08/2021		07/14/2021	100.00
96 - PACE Suburban Bus	592539	1 Van @100 each	Paid by Check # 58823		07/08/2021	07/08/2021	07/08/2021		07/14/2021	100.00
96 - PACE Suburban Bus	592540	1 Van @100 each	Paid by Check # 58823		07/08/2021	07/08/2021	07/08/2021		07/14/2021	100.00
96 - PACE Suburban Bus	592541	1 Van @100 each	Paid by Check # 58823		07/08/2021	07/08/2021	07/08/2021		07/14/2021	100.00
Account 5505 - Equipment Lease Totals								Invoice Transactions	6	<u>\$600.00</u>
Department 46 - Senior Citizen Program Totals								Invoice Transactions	15	<u>\$8,729.65</u>
Fund 100 - General Fund Totals								Invoice Transactions	247	<u>\$1,477,883.64</u>
Fund 205 - Library Fund										
Department 40 - Library										
Account 5105-07 - Community Programs Adult/Children Programs										
5868 - Ann Rinderer	2021-00000545	Community Programs Adult/Children Programs	Paid by Check # 58633		06/18/2021	06/18/2021	06/18/2021		06/24/2021	650.00
3599 - First Book	700429669	Community Programs Adult/Children Programs	Paid by Check # 58793		07/06/2021	07/06/2021	07/06/2021		07/14/2021	1,500.61
37680 - Uline	134856061	Community Programs Adult/Children Programs	Paid by Check # 58855		07/06/2021	07/06/2021	07/06/2021		07/14/2021	194.12
Account 5105-07 - Community Programs Adult/Children Programs Totals								Invoice Transactions	3	<u>\$2,344.73</u>
Account 5105-80 - Community Programs Per Capita										
515 - Able Printing Service	46532	Community Programs Per Capita	Paid by Check # 58756		07/06/2021	07/06/2021	07/06/2021		07/14/2021	614.54



Accounts Payable by G/L Distribution Report

Payment Date Range 06/24/21 - 07/14/21

Vendor	Invoice No.	Invoice Description	Status	Held Reason	Invoice Date	Due Date	G/L Date	Received Date	Payment Date	Invoice Amount	
Fund 205 - Library Fund											
Department 40 - Library											
Account 5105-80 - Community Programs Per Capita											
3599 - First Book	700429669	Community Programs Adult/Children Programs	Paid by Check # 58793		07/06/2021	07/06/2021	07/06/2021		07/14/2021	514.80	
									Account 5105-80 - Community Programs Per Capita Totals	Invoice Transactions 2	\$1,129.34
Account 5215 - Telephone											
4024 - AT & T	708795579406-4	Telephone	Paid by Check # 58762		07/06/2021	07/06/2021	07/06/2021		07/14/2021	56.34	
4024 - AT & T	708795808206-5	Telephone	Paid by Check # 58762		07/06/2021	07/06/2021	07/06/2021		07/14/2021	1,254.20	
									Account 5215 - Telephone Totals	Invoice Transactions 2	\$1,310.54
Account 5220 - Training, Dues & Publications											
30390 - Illinois Library Association	196382	Training, Dues & Publications	Paid by Check # 58799		07/06/2021	07/06/2021	07/06/2021		07/14/2021	100.00	
									Account 5220 - Training, Dues & Publications Totals	Invoice Transactions 1	\$100.00
Account 5225 - Supplies											
31968 - Berwyn's Violet Flower Shop	008176	Supplies	Paid by Check # 58768		07/06/2021	07/06/2021	07/06/2021		07/14/2021	40.00	
996 - Case Lots, Inc.	5388	Supplies	Paid by Check # 58774		07/06/2021	07/06/2021	07/06/2021		07/14/2021	226.70	
5647 - El Dia Newspaper	2021-00000664	Supplies	Paid by Check # 58790		07/06/2021	07/06/2021	07/06/2021		07/14/2021	200.00	
5426 - Menards	61628	Supplies	Paid by Check # 58813		07/06/2021	07/06/2021	07/06/2021		07/14/2021	169.41	
30520 - Midwest Tape	500548977	Books Per Capita	Paid by Check # 58816		07/06/2021	07/06/2021	07/06/2021		07/14/2021	201.99	
37680 - Uline	135187310	Supplies	Paid by Check # 58855		07/06/2021	07/06/2021	07/06/2021		07/14/2021	46.86	
									Account 5225 - Supplies Totals	Invoice Transactions 6	\$884.96
Account 5225-80 - Supplies Per Capita											
31341 - Jan Way Company USA, Inc.	138236	Supplies Per Capita	Paid by Check # 58802		07/06/2021	07/06/2021	07/06/2021		07/14/2021	188.97	
37680 - Uline	134856061	Community Programs Adult/Children Programs	Paid by Check # 58855		07/06/2021	07/06/2021	07/06/2021		07/14/2021	129.40	
6105 - Villa Park Office Equipment, Inc	72267	Supplies Per Capita	Paid by Check # 58857		07/06/2021	07/06/2021	07/06/2021		07/14/2021	3,395.00	
									Account 5225-80 - Supplies Per Capita Totals	Invoice Transactions 3	\$3,713.37
Account 5225-82 - Supplies Other Grants											
989 - T-Mobile	972638993-1	Supplies Other Grants Age Options	Paid by Check # 58845		07/06/2021	07/06/2021	07/06/2021		07/14/2021	173.43	
									Account 5225-82 - Supplies Other Grants Totals	Invoice Transactions 1	\$173.43



Accounts Payable by G/L Distribution Report

Payment Date Range 06/24/21 - 07/14/21

Vendor	Invoice No.	Invoice Description	Status	Held Reason	Invoice Date	Due Date	G/L Date	Received Date	Payment Date	Invoice Amount
Fund 205 - Library Fund										
Department 40 - Library										
Account 5245 - Books										
6236 - Bibliotheca LLC	INV-US44907	Computer Databases	Paid by Check # 58769		07/06/2021	07/06/2021	07/06/2021		07/14/2021	3,642.00
5679 - Children's Plus Inc	199846	Books	Paid by Check # 58777		07/06/2021	07/06/2021	07/06/2021		07/14/2021	1,355.63
398 - Ingram Library Services LLC	53311685	Books	Paid by Check # 58800		07/06/2021	07/06/2021	07/06/2021		07/14/2021	4,193.86
3894 - Overdrive	H-0072890	Computer Databases	Paid by Check # 58821		07/06/2021	07/06/2021	07/06/2021		07/14/2021	6,000.00
								Account 5245 - Books Totals	Invoice Transactions 4	\$15,191.49
Account 5245-80 - Books Per Capita										
3599 - First Book	700429669	Community Programs Adult/Children Programs	Paid by Check # 58793		07/06/2021	07/06/2021	07/06/2021		07/14/2021	235.00
30520 - Midwest Tape	500548977	Books Per Capita	Paid by Check # 58816		07/06/2021	07/06/2021	07/06/2021		07/14/2021	1,066.80
								Account 5245-80 - Books Per Capita Totals	Invoice Transactions 2	\$1,301.80
Account 5250 - Audio Visual										
1545 - Blackstone Publishing	1229053	Audio Visual	Paid by Check # 58770		07/06/2021	07/06/2021	07/06/2021		07/14/2021	301.70
30520 - Midwest Tape	500548977	Books Per Capita	Paid by Check # 58816		07/06/2021	07/06/2021	07/06/2021		07/14/2021	169.86
								Account 5250 - Audio Visual Totals	Invoice Transactions 2	\$471.56
Account 5255 - Periodicals										
1299 - Chicago Sun-Times, Inc.	185615-1	Periodicals	Paid by Check # 58776		07/06/2021	07/06/2021	07/06/2021		07/14/2021	785.48
								Account 5255 - Periodicals Totals	Invoice Transactions 1	\$785.48
Account 5400 - Repairs & Maintenance										
5981 - Crystal Maintenance Services	27605	Cleaning Services	Paid by Check # 58783		07/06/2021	07/06/2021	07/06/2021		07/14/2021	81.66
33491 - Today's Business Solutions	12041	Contract Maintenance	Paid by Check # 58852		07/06/2021	07/06/2021	07/06/2021		07/14/2021	1,330.00
								Account 5400 - Repairs & Maintenance Totals	Invoice Transactions 2	\$1,411.66
Account 5525 - Computer Support Databases										
4324 - CablesAndKits.com	520943	Computer Support Databases	Paid by Check # 58773		07/06/2021	07/06/2021	07/06/2021		07/14/2021	104.99
4033 - eDot	71197	Computer Support Databases	Paid by Check # 58789		07/06/2021	07/06/2021	07/06/2021		07/14/2021	2,114.00
								Account 5525 - Computer Support Databases Totals	Invoice Transactions 2	\$2,218.99
Account 5660 - Promotions										
3861 - Combined Veterans of Berwyn	2021-00000663	Promotions	Paid by Check # 58779		07/06/2021	07/06/2021	07/06/2021		07/14/2021	100.00
								Account 5660 - Promotions Totals	Invoice Transactions 1	\$100.00



Accounts Payable by G/L Distribution Report

Payment Date Range 06/24/21 - 07/14/21

Vendor	Invoice No.	Invoice Description	Status	Held Reason	Invoice Date	Due Date	G/L Date	Received Date	Payment Date	Invoice Amount
Fund 205 - Library Fund										
							Department 40 - Library Totals		Invoice Transactions 32	<u>\$31,137.35</u>
							Fund 205 - Library Fund Totals		Invoice Transactions 32	<u>\$31,137.35</u>
Fund 210 - Community Development Fund										
Department 42 - CDBG										
Account 5400-01 - Repairs & Maintenance Sewer										
5149 - M & J Asphalt Paving	20010	PY 2019 Sewer Replacement	Paid by Check # 58752		06/23/2021	06/23/2021	06/23/2021	07/07/2021		76,423.50
							Account 5400-01 - Repairs & Maintenance Sewer Totals		Invoice Transactions 1	<u>\$76,423.50</u>
Account 5400-02 - Repairs & Maintenance Street/Sidewalk										
5149 - M & J Asphalt Paving	20010-1	PY 2019 Street Replacement	Paid by Check # 58752		06/23/2021	06/23/2021	06/23/2021	07/07/2021		196,782.30
							Account 5400-02 - Repairs & Maintenance Street/Sidewalk Totals		Invoice Transactions 1	<u>\$196,782.30</u>
							Department 42 - CDBG Totals		Invoice Transactions 2	<u>\$273,205.80</u>
							Fund 210 - Community Development Fund Totals		Invoice Transactions 2	<u>\$273,205.80</u>
Fund 215 - Motor Fuel Tax Fund										
Account 5205 - Utilities										
5801 - Direct Energy Business	2117600460411	june 2021 electric 60	Paid by Check # 58787		07/07/2021	07/07/2021	07/07/2021	07/14/2021		189.82
5801 - Direct Energy Business	2117500460257	june 2021 electric 03	Paid by Check # 58787		07/07/2021	07/07/2021	07/07/2021	07/14/2021		147.20
5801 - Direct Energy Business	2117500460257	june 2021 electric 02	Paid by Check # 58787		07/07/2021	07/07/2021	07/07/2021	07/14/2021		57.02
							Account 5205 - Utilities Totals		Invoice Transactions 3	<u>\$394.04</u>
Account 5225-05 - Supplies Rock Salt										
449 - Morton Salt, Inc.	5402243433	rock salk	Paid by Check # 58751		06/30/2021	06/30/2021	06/30/2021	06/30/2021		19,889.85
449 - Morton Salt, Inc.	5402245174	rock salk	Paid by Check # 58751		06/30/2021	06/30/2021	06/30/2021	06/30/2021		7,712.30
							Account 5225-05 - Supplies Rock Salt Totals		Invoice Transactions 2	<u>\$27,602.15</u>
Account 5400-03 - Repairs & Maintenance Traffic control										
3047 - H & H Electric Company	36842	non-routine maint.	Paid by Check # 58643		06/18/2021	06/18/2021	06/18/2021	06/24/2021		540.25
3047 - H & H Electric Company	36841	non-routine maint.	Paid by Check # 58643		06/18/2021	06/18/2021	06/18/2021	06/24/2021		471.46
3047 - H & H Electric Company	36843	non-routine maint.	Paid by Check # 58643		06/18/2021	06/18/2021	06/18/2021	06/24/2021		5,406.96
3047 - H & H Electric Company	36844	non-routine maint.	Paid by Check # 58643		06/18/2021	06/18/2021	06/18/2021	06/24/2021		566.70
3047 - H & H Electric Company	36845	non-routine maint.	Paid by Check # 58724		06/30/2021	06/30/2021	06/30/2021	06/30/2021		2,939.04
							Account 5400-03 - Repairs & Maintenance Traffic control Totals		Invoice Transactions 5	<u>\$9,924.41</u>
							Fund 215 - Motor Fuel Tax Fund Totals		Invoice Transactions 10	<u>\$37,920.60</u>



Accounts Payable by G/L Distribution Report

Payment Date Range 06/24/21 - 07/14/21

Vendor	Invoice No.	Invoice Description	Status	Held Reason	Invoice Date	Due Date	G/L Date	Received Date	Payment Date	Invoice Amount
Fund 220 - South Berwyn Corridor TIF Fund										
Account 5800 - Capital Outlay										
78 - Berwyn Development Corporation	46570	TIFS / S.Berwyn, Harlem, & Roosevelt Rd	Paid by Check # 58710		06/29/2021	06/29/2021	06/29/2021		06/30/2021	136.18
5954 - WeOurStory	2021-00000674	TIFS / S.Berwyn, Harlem, & Roosevelt Rd	Paid by Check # 58859		07/07/2021	07/07/2021	07/07/2021		07/14/2021	116.66
							Account 5800 - Capital Outlay Totals	Invoice Transactions 2		<u>\$252.84</u>
							Fund 220 - South Berwyn Corridor TIF Fund Totals	Invoice Transactions 2		<u>\$252.84</u>
Fund 223 - Harlem Avenue TIF Fund										
Account 5800 - Capital Outlay										
78 - Berwyn Development Corporation	46570	TIFS / S.Berwyn, Harlem, & Roosevelt Rd	Paid by Check # 58710		06/29/2021	06/29/2021	06/29/2021		06/30/2021	136.17
5954 - WeOurStory	2021-00000674	TIFS / S.Berwyn, Harlem, & Roosevelt Rd	Paid by Check # 58859		07/07/2021	07/07/2021	07/07/2021		07/14/2021	116.67
							Account 5800 - Capital Outlay Totals	Invoice Transactions 2		<u>\$252.84</u>
							Fund 223 - Harlem Avenue TIF Fund Totals	Invoice Transactions 2		<u>\$252.84</u>
Fund 230 - Roosevelt Road TIF Fund										
Account 5800 - Capital Outlay										
78 - Berwyn Development Corporation	46570	TIFS / S.Berwyn, Harlem, & Roosevelt Rd	Paid by Check # 58710		06/29/2021	06/29/2021	06/29/2021		06/30/2021	136.17
5954 - WeOurStory	2021-00000674	TIFS / S.Berwyn, Harlem, & Roosevelt Rd	Paid by Check # 58859		07/07/2021	07/07/2021	07/07/2021		07/14/2021	116.67
							Account 5800 - Capital Outlay Totals	Invoice Transactions 2		<u>\$252.84</u>
							Fund 230 - Roosevelt Road TIF Fund Totals	Invoice Transactions 2		<u>\$252.84</u>
Fund 245 - Federal Asset Forfeiture Fund										
Department 20 - Police Department										
Account 5191-15 - State Law Enforcement Expenses										
5256 - Partners & Paws Veterinary Services	92482	K-9 Boarding	Paid by Check # 58824		07/06/2021	07/06/2021	07/06/2021		07/14/2021	315.00
5256 - Partners & Paws Veterinary Services	88786	K-9 Medical	Paid by Check # 58824		07/06/2021	07/06/2021	07/06/2021		07/14/2021	172.91
5256 - Partners & Paws Veterinary Services	91596	K-9 Medical	Paid by Check # 58824		07/06/2021	07/06/2021	07/06/2021		07/14/2021	141.39
5256 - Partners & Paws Veterinary Services	92717	K-9 Medical	Paid by Check # 58824		07/06/2021	07/06/2021	07/06/2021		07/14/2021	72.67
							Account 5191-15 - State Law Enforcement Expenses Totals	Invoice Transactions 4		<u>\$701.97</u>



Accounts Payable by G/L Distribution Report

Payment Date Range 06/24/21 - 07/14/21

Vendor	Invoice No.	Invoice Description	Status	Held Reason	Invoice Date	Due Date	G/L Date	Received Date	Payment Date	Invoice Amount
Fund 245 - Federal Asset Forfeiture Fund										
Department 20 - Police Department										
Account 5191-45 - State Firearms / Weapons										
ALS	043637	Tac Wedge Ops	Paid by Check # 58863		07/06/2021	07/06/2021	07/06/2021		07/14/2021	999.76
							Account 5191-45 - State Firearms / Weapons Totals		Invoice Transactions 1	<u>\$999.76</u>
Account 5192-30 - Federal LE, PS, Detention Facilities										
302 - Sprint	484479818-162	May 04 - June 03 2021	Paid by Check # 58739		06/29/2021	06/29/2021	06/29/2021		06/30/2021	209.95
							Account 5192-30 - Federal LE, PS, Detention Facilities Totals		Invoice Transactions 1	<u>\$209.95</u>
Account 5192-35 - Federal LE Operations / Investigations										
3757 - Thomson Reuters - West	844534219	Research/Crim.-IVC Books	Paid by Check # 58743		06/29/2021	06/29/2021	06/29/2021		06/30/2021	2,885.74
3757 - Thomson Reuters - West	844443088	Research Data Base	Paid by Check # 58743		06/29/2021	06/29/2021	06/29/2021		06/30/2021	439.12
							Account 5192-35 - Federal LE Operations / Investigations Totals		Invoice Transactions 2	<u>\$3,324.86</u>
							Department 20 - Police Department Totals		Invoice Transactions 8	<u>\$5,236.54</u>
							Fund 245 - Federal Asset Forfeiture Fund Totals		Invoice Transactions 8	<u>\$5,236.54</u>
Fund 300 - Debt Service Fund										
Account 5200 - Administrative Expenses										
1504 - The Bank of New York Mellon	252-2392305	Berwyn IL Taxable General Obligation Bonds Series 2007A	Paid by Check # 58742		06/29/2021	06/29/2021	06/29/2021		06/30/2021	750.00
1504 - The Bank of New York Mellon	252-2392306	Berwyn IL Taxable General Obligation Bonds Series 2007B	Paid by Check # 58742		06/29/2021	06/29/2021	06/29/2021		06/30/2021	750.00
							Account 5200 - Administrative Expenses Totals		Invoice Transactions 2	<u>\$1,500.00</u>
							Fund 300 - Debt Service Fund Totals		Invoice Transactions 2	<u>\$1,500.00</u>
Fund 500 - Utilities Fund										
Department 44 - Water & Sewer										
Account 5205 - Utilities										
473 - Tyler Technologies, Inc.	045-345618	Utility Services	Paid by Check # 58854		07/07/2021	07/07/2021	07/07/2021		07/14/2021	320.00
							Account 5205 - Utilities Totals		Invoice Transactions 1	<u>\$320.00</u>
Account 5215 - Telephone										
4024 - AT & T	708788456906-4	June 2021 phone bill	Paid by Check # 58762		07/07/2021	07/07/2021	07/07/2021		07/14/2021	1,745.65
							Account 5215 - Telephone Totals		Invoice Transactions 1	<u>\$1,745.65</u>
Account 5225 - Supplies										
4711 - Continental Research Corporation	0025218	supplies	Paid by Check # 58781		07/07/2021	07/07/2021	07/07/2021		07/14/2021	5,206.63



Accounts Payable by G/L Distribution Report

Payment Date Range 06/24/21 - 07/14/21

Vendor	Invoice No.	Invoice Description	Status	Held Reason	Invoice Date	Due Date	G/L Date	Received Date	Payment Date	Invoice Amount
Fund 500 - Utilities Fund										
Department 44 - Water & Sewer										
Account 5225 - Supplies										
162 - Jack's Rental, Inc.	84820	supplies	Paid by Check # 58801		07/07/2021	07/07/2021	07/07/2021		07/14/2021	920.24
							Account 5225 - Supplies Totals		Invoice Transactions 2	<u>\$6,126.87</u>
Account 5235 - Postage & Printing										
465 - Diamond Graphics, Inc.	0102830893	ccr report printing	Paid by Check # 58786		07/07/2021	07/07/2021	07/07/2021		07/14/2021	4,034.00
							Account 5235 - Postage & Printing Totals		Invoice Transactions 1	<u>\$4,034.00</u>
Account 5300 - Professional Services										
5155 - Gei Consultants	3091639	engineering services	Paid by Check # 58641		06/18/2021	06/18/2021	06/18/2021		06/24/2021	4,200.00
1751 - Suburban Laboratories, Inc.	190868	water testing	Paid by Check # 58842		07/07/2021	07/07/2021	07/07/2021		07/14/2021	1,710.00
							Account 5300 - Professional Services Totals		Invoice Transactions 2	<u>\$5,910.00</u>
Account 5505 - Equipment Lease										
29 - Pitney Bowes	3104764792	Equipment Lease	Paid by Check # 58732		06/29/2021	06/29/2021	06/29/2021		06/30/2021	2,412.00
							Account 5505 - Equipment Lease Totals		Invoice Transactions 1	<u>\$2,412.00</u>
Account 5800-41 - Capital Outlay Flood Mitigation Program										
MARTIN PEREZ & MARIBEL MORALES	504	FLOOD MITIGATION PROGRAM	Paid by Check # 58699		06/29/2021	06/29/2021	06/29/2021		06/29/2021	3,500.00
EDWARD R. CIESIELSKI	513	FLOOD MITIGATION PROGRAM	Paid by Check # 58864		07/07/2021	07/07/2021	07/07/2021		07/14/2021	3,500.00
GREG SALVINO	640	FLOOD MITIGATION PROGRAM	Paid by Check # 58867		07/07/2021	07/07/2021	07/07/2021		07/14/2021	3,500.00
KATHRYN KINCAID	585	FLOOD MITIGATION PROGRAM	Paid by Check # 58870		07/07/2021	07/07/2021	07/07/2021		07/14/2021	3,500.00
							Account 5800-41 - Capital Outlay Flood Mitigation Program Totals		Invoice Transactions 4	<u>\$14,000.00</u>
							Department 44 - Water & Sewer Totals		Invoice Transactions 12	<u>\$34,548.52</u>
							Fund 500 - Utilities Fund Totals		Invoice Transactions 12	<u>\$34,548.52</u>
Fund 550 - Parking Garage Fund										
Account 5205 - Utilities										
5801 - Direct Energy Business	211760046041159	june 2021 electric	Paid by Check # 58787		07/07/2021	07/07/2021	07/07/2021		07/14/2021	1,344.13
							Account 5205 - Utilities Totals		Invoice Transactions 1	<u>\$1,344.13</u>
Account 5400 - Repairs & Maintenance										
5981 - Crystal Maintenance Services	27605	Cleaning Services	Paid by Check # 58783		07/06/2021	07/06/2021	07/06/2021		07/14/2021	.01
							Account 5400 - Repairs & Maintenance Totals		Invoice Transactions 1	<u>\$0.01</u>
							Fund 550 - Parking Garage Fund Totals		Invoice Transactions 2	<u>\$1,344.14</u>



Accounts Payable by G/L Distribution Report

Payment Date Range 06/24/21 - 07/14/21

Vendor	Invoice No.	Invoice Description	Status	Held Reason	Invoice Date	Due Date	G/L Date	Received Date	Payment Date	Invoice Amount
Fund 600 - Internal Service Fund										
Account 5630 - Premiums - Liability										
3392 - Mesirow Insurance Services, Inc.	1646898	Renewal Public Officials Bond-Ben Daish	Paid by Check # 58625		06/18/2021	06/18/2021	06/18/2021		06/24/2021	150.00
3392 - Mesirow Insurance Services, Inc.	1665633	BFF Pension Fiduciary #MGL001190806	Paid by Check # 58625		06/18/2021	06/18/2021	06/18/2021		06/24/2021	5,158.00
3392 - Mesirow Insurance Services, Inc.	1668894	BPD Pension Fiduciary #MGL00147780	Paid by Check # 58625		06/18/2021	06/18/2021	06/18/2021		06/24/2021	6,331.00
3392 - Mesirow Insurance Services, Inc.	1635803	Renewal Public Officials Bond	Paid by Check # 58625		06/18/2021	06/18/2021	06/18/2021		06/24/2021	150.00
							Account 5630 - Premiums - Liability Totals	Invoice Transactions	4	<u>\$11,789.00</u>
							Fund 600 - Internal Service Fund Totals	Invoice Transactions	4	<u>\$11,789.00</u>
							Grand Totals	Invoice Transactions	325	<u>\$1,875,324.11</u>

Robert J. Lovero
Mayor



Charles D. Lazzara
Building Director

A Century of Progress with Pride

6700 West 26th Street Berwyn, Illinois 60402-0701 Telephone: (708) 788-2660 Fax: (708) 788-1427
www.berwyn-il.gov

K-4

July 1, 2021

Honorable Robert J. Lovero
Mayor of the City of Berwyn
Members of City Council

Re: Building and Local Improvement Permits

Gentlemen:

Attached are the financial report of Building and Local Improvement Permits issued by the City of Berwyn for the month of June 2021, along with a copy of Permit Statistics for this same period.

Respectfully,

Charles D. Lazzara
Building Director

Report Of Building Permits Issued By The City Of Berwyn

Thursday, July 1, 2021

Between: 6/1/2021 And 6/30/2021

Name and Address	Issued	Permit No.	Cost Of Improvements	Cost Of Permit
Adam Borzecki 3843 S. Wesley Avenue	6/30/2021	Bldg-B 9111-1	\$0.00	\$50.00
ELECTRICAL FINAL RE-INSPECTION----- INTERIOR REMODEL: ADD BEDROOM AND BATHROOM (1 EXISTING, 1 NEW) NEW ELECTRICAL FIXTURES AND UPDATES, PLUMBING, INTERIOR STRUCTURAL ALTERATIONS, DEMOLITION IN KITCHEN AND (1) WALL 1ST FL. REMODEL BATHR				
R & I Real Estate Investments LL 3240-42 S. Oak Park Avenue	6/4/2021	Bldg-B 9362-2	\$0.00	\$150.00
PAYING FOR INSPECTION FEES. 2 PLUMBING FINAL INSPS, ELECTRICAL ROUGH AND WATER PRESSURE TEST.				
James Hickey & Rachelle Thero 1509 S. Grove Avenue	6/1/2021	Bldg-B 9470-2	\$0.00	\$100.00
PAYING FOR PARKWAY AND RESTORATION REINSPECTIONS				
Luis D. Blanco and Wendy Sanch 1602 S. Highland Avenue	6/11/2021	Bldg-B 9532-1	\$400.00	\$190.00
REVENT THE BASEMENT BATHROOM, INSTALL A VENT TO EJECTOR PIT AND DECONVERT THE GREY BOX, LAUNDRY MACHINE AND DRYER (THERE WILL NOT BE A LAUNDRY ROOM AT THIS PROPERTY).PAYING FOR ATF PLUMBING INSPECTION FROM THE ORIGINAL PERMIT.				
RMG Homes LLC 3606 S. Wenonah Avenue	6/11/2021	Bldg-B 9539-2	\$10,000.00	\$385.00
SEWER REPAIR IN THE STREET.				
Merriment Homes Inc. 2626 S. Kenilworth Avenue	6/4/2021	Bldg-B 9631-1	\$0.00	\$50.00
PAYING FOR THE ADDITIONAL PRE-POUR INSPECTION FOR THE SIDEWALK AND CURB.				
R. Pavone & D. Vela 2843 S. Home Avenue	6/30/2021	Gar-B 9666-2	\$0.00	\$100.00
PAYING FOR ELECTRICAL UNDERGROUND AND ELECTRICAL FINAL RE-INSPECTIONS-----REBUILD A NEW 22' X 24' X 16'(H) GARAGE. ADDING TO PERMIT 4/20/21 R/R EXISTING CONCRETE PATIO.				
Adolf Vega Trust 2829 S. Ridgeland Avenue	6/1/2021	Bldg-B 9668-1	\$0.00	\$50.00
PAYING FOR ELECTRICAL ROUGH RE-INSPECTION-----INTERIOR REMODEL . 1ST FLOOR- KITCHEN, FAMILY ROOM, DINING ROOM, ADD FULL BATHROOM, 2 EXISTING BEDROOMS. 2ND FLOOR- NO WORK. BASEMENT- FINISHED WITH NEW 1/2 BATHROOM, NO BEDROOM, MECHANICAL R				
Pedro Tamayo & Dayenis Urquijo 1818 S. East Avenue	6/15/2021	Bldg-B 9703-2	\$0.00	\$0.00
THIS PERMIT IS FOR THE PURPOSE OF DECONVERTING ANY PLUMBING THAT WAS RUN UP THE ATTIC BATHROOM THAT WILL NOT LONGER BE INSTALLED.				
IL Property Solutions LLC 3739 S. Harvey Avenue	6/8/2021	Bldg-B 9715-2	\$0.00	\$50.00
ELECTRICAL ROUGH RE-INSPECTION - 1ST FLR: KITCHEN, LIVING ROOM, FULL EXISTING BATH, TWO BEDROOMS. BSMT: FINISHED, EXISTING 3/4 BATH, 1 EXISTING BEDROOM, LAUNDRY ROOM, MECHANICAL ROOM. TWO BATHROOM REMODELS (TILES & FIXTURES), KITCHEN REMODEL (TILES & FIXT				
Ramon Valladarez 1544 S. Grove Avenue	6/3/2021	Bldg-B 9723-1	\$0.00	\$50.00
DUMPSTER ON THE STREET TO REMOVE ALL CONSTRUCTION DEBRIS. DUMPSTERS/PODS REQUIRE A FLASHING BARRICADE ON THE SIDE OF INCOMMING TRAFFIC.				

Report Of Building Permits Issued By The City Of Berwyn

Thursday, July 1, 2021

Between: 6/1/2021 And 6/30/2021

Name and Address	Issued	Permit No.	Cost Of Improvements	Cost Of Permit
Juan Torres 1624 S. Wisconsin Avenue	6/2/2021	Bldg-B 9742-2	\$0.00	\$50.00
PAYING FOR PLUMBING ROUGH RE-INSPECTION-----KITHCEN REMODEL, BASEMENT BATHROOM REMODEL, MAIN LEVEL BATHROOM REMODEL , CREATING 2 BEDROOM IN THE ATTIC, BASEMENT CONSISTS OF OFFICE, LAUNDRY ROOM, MECHANICAL ROOM, DRY BAR, EXISITNG 3/4 BATH, WITH OP				
Molly J. Masters & Nicholas G. P 3205 S. Wisconsin Avenue	6/7/2021	Gar-B 9761-0	\$29,500.00	\$325.00
DEMO AND REBUILD A 24'X22' 12'8" (H) GARAGE.				
Gerardo Roman 2318 S. Highland Avenue	6/7/2021	Bldg-B 9762-0	\$10,200.00	\$405.00
INSTALL BOILERS TO FORCED AIR WITH NEW FURNACE, DUCTWORK AND A/C UNIT. A/C CONDENSERS MUST BE LOCATED BEHIND THE HOUSE 3' FROM PROPERTY LOT LINE AND ELECTRICAL METER. ALL BEDROOMS REQUIRE A RETURN.				
Errol McLendon & Wendy Claren 1411 S. Wenonah Avenue	6/7/2021	Gar-B 9763-0	\$24,235.00	\$325.00
DEMO EXISTING GARAGE 12X18 FRAME, SLAB, APRON AND 2X18 WALK. NEW 19X20 GARAGE, FRAME CONCRETE SLAB AND 5' APRON.				
Alison N Teague 3812 S. Ridgeland Avenue	6/7/2021	Gar-B 9764-0	\$21,850.00	\$300.00
REMOVE CONCRETE SLAB 14X22, APRON 5' AND WALK 3X6. NEW GARAGE FRAME 18X22, CONCRETE SLAB 18X22 APRON 18X3 AND WALK 3X6				
Erika Kirchgatterer 6928 W. 34th Street	6/9/2021	Gar-B 9765-0	\$39,111.00	\$325.00
DEMO EXISTING GARAGE AND BUILD NEW 24X24X12(H)				
Pilsen-Little Village Mental Health 2600 S. Ridgeland Avenue	6/8/2021	Bldg-B 9766-0	\$500,000.00	\$10,062.50
REMODEL 2 BATHROOMS, R/R WINDOWS, ADDING AN ELEVATOR AND POURING NEW CONCRETE. DUMPSTERS/PODS REQUIRE A FLASHING BARRICADE ON THE SIDE OF INCOMMING TRAFFIC.				
Love Real Estate Solutions LLC 2335 S. Scoville Avenue	6/21/2021	Bldg-B 9767-0	\$150,000.00	\$5,190.00
INTERIOR REMODEL WITH 2ND FLOOR ADDITION, NEW 20'X20'X16'(H) GARAGE. 1ST FLOOR WILL CONSIST OF KITCHEN, DINING ROOM, LIVING ROOM, POWDER ROOM, PANTRY, BREAKFAST AREA AND DEN AREA. THE 2ND FLOOR WILL CONSIST OF 3 NEW BEDROOMS, A NEW FULL BATHROOM, A NEW 3/				
German & Lumir Luna 1215 S. Harvey Avenue	6/10/2021	Gar-B 9768-0	\$12,000.00	\$300.00
BUILD A NEW GARAGE 19' X 19' X 16'(H)				
David T & Angela F Crawford Ne 3834 S. Wenonah Avenue	6/10/2021	Bldg-B 9769-0	\$6,500.00	\$240.00
R/R FURNACE AND INSTALL A NEW A/C UNIT -- PER CDL A/C UNIT WILL BE ALLOWED TO BE IN THE SIDE YARD(*ALLEY SIDE)				
Eric Fredericks & Nora Frederick 7053 W. 26th Parkway	6/11/2021	Gar-B 9770-0	\$24,500.00	\$325.00
DEMO AND REBUILD A 24'X20' X 12'(H) GARAGE.				
Rapport Builders LLC 1828 S. Highland Avenue	6/14/2021	Bldg-B 9772-0	\$104,500.00	\$4,010.00
INTERIOR REMODEL. 1ST FLOOR TO CONSIST OF- KITCHEN, DINING ROOM, LIVING ROOM, FULL BATH EXISTING, 1 EXISTING BEDROOM. 2ND FLOOR/ATTIC TO CONSIST OF- RECREATIONAL ROOM, FULL BATH EXISTING, 3 EXISTING BEDROOMS. FINISHED BASEMENT TO CONSIST OF- FULL BATH EXI				
Francisco Allen 1423 S. Cuyler Avenue	6/15/2021	Gar-B 9773-0	\$0.00	\$25.00
EMERGENCY GARAGE DEMO.				

Report Of Building Permits Issued By The City Of Berwyn

Thursday, July 1, 2021

Between: 6/1/2021 And 6/30/2021

<i>Name and Address</i>	<i>Issued</i>	<i>Permit No.</i>	<i>Cost Of Improvements</i>	<i>Cost Of Permit</i>
Mr. Zitnik 1404 S. Gunderson Avenue	6/17/2021	Gar-B 9774-0	\$21,500.00	\$325.00
R. & E. Vargas 2421 S. East Avenue	6/18/2021	Bldg-B 9775-0	\$0.00	\$860.00
Sean Sullivan 3823 S. Kenilworth Avenue	6/22/2021	Gar-B 9776-0	\$22,427.25	\$0.00
ISAAC OSIO 1448 S. Gunderson Avenue	6/23/2021	Bldg-B 9778-0	\$2,000.00	\$665.00
Natali Gonzales-Nazario 6433 W. 34th Street	6/24/2021	Gar-B 9779-0	\$10,000.00	\$325.00
David Reyes Salvador 6747 W. Riverside Drive	6/25/2021	Bldg-B 9780-0	\$50,000.00	\$1,660.00
Gustavo & Elizabeth Chavez 1638 S. Elmwood Avenue	6/25/2021	Bldg-B 9781-0	\$60,000.00	\$1,650.00
Edward & Myrna Curra 3121 S. Wesley Avenue	6/30/2021	Gar-B 9782-0	\$35,801.00	\$40.00
Erika Romero & Jorge Gonzalez 3341 S. Harvey Avenue	6/30/2021	Gar-B 9783-0	\$32,300.00	\$350.00
Raymundo & Rosaura Razo 3825 S. Oak Park Avenue	6/30/2021	Bldg-B 9784-0	\$8,200.00	\$375.00
Martin S. Martinez & Nancy Marti 2844 S. Highland Avenue	6/30/2021	Bldg-B 9785-0	\$2,000.00	\$765.00
35 Building Permits Issued During Period	Totals		<u>\$1,177,024.25</u>	<u>\$30,072.50</u>

Permits Issued By The Building Department

Thursday, July 1, 2021

Between: 6/1/2021 And 6/30/2021

<u>Building</u>	Permits Issued: 22	Cost of Improvements: \$903,800.00
<u>Dumpster</u>	Permits Issued: 12	Cost of Improvements: \$0.00
<u>Electrical</u>	Permits Issued: 22	Cost of Improvements: \$41,505.00
<u>Fence</u>	Permits Issued: 47	Cost of Improvements: \$153,145.00
<u>Garage</u>	Permits Issued: 13	Cost of Improvements: \$273,224.25
<u>HVAC</u>	Permits Issued: 36	Cost of Improvements: \$247,114.55
<u>Local Improvement</u>	Permits Issued: 296	Cost of Improvements: \$2,062,531.66
<u>Plumbing</u>	Permits Issued: 16	Cost of Improvements: \$81,830.42
<u>POD</u>	Permits Issued: 2	Cost of Improvements: \$0.00
<u>Roofing</u>	Permits Issued: 51	Cost of Improvements: \$420,618.41
<u>Sign</u>	Permits Issued: 3	Cost of Improvements: \$12,990.00
	Total Permits: <u>520</u>	Total Improvements: <u>\$4,196,759.29</u>

Fees Collected

Building Permit Fee	\$13,195.00
Permit Final	\$8,760.00
Chimney Liner Rough	\$50.00

Permits Issued By The Building Department

Thursday, July 1, 2021

Between: 6/1/2021 And 6/30/2021

Chimney Liner Final	\$50.00
Gutter/Downspout Final Inspection	\$800.00
Masonry Final Inspection	\$1,200.00
Local Improvement Permit Fee	\$32,545.00
Electrical Rough	\$2,450.00
Electrical Above Ceiling Inspection	\$250.00
Electrical Permit Fees	\$1,055.00
Electrical Underground	\$750.00
Electrical Service	\$650.00
Electrical Final	\$5,200.00
Sign Permit Fees	\$230.00
Footing Inspection	\$140.00
Preliminary Framing	\$65.00
Framing Rough	\$2,570.00
Fence Permit Fee	\$1,470.00
Plumbing Rough	\$2,150.00
Plumbing Permit Fees	\$635.00
Hydronic Deconversion	\$250.00
Plumbing Final	\$2,700.00
Preliminary Plumbing	\$100.00
Plumbing Inspection Underground	\$1,200.00
ATF Plumbing	\$50.00
Plumbing Underground-Tap	\$300.00
Plumbing Underground-Service	\$300.00
Plumbing Underground-Divorce	\$300.00
Plumbing Underground-PVC Installation	\$300.00
Plumbing Underground-Bedding Inspection	\$300.00
Plumbing Underground-Head Test	\$300.00
Post Hole/Pier Inspection	\$3,130.00
RPZ Test/DDCA Valve	\$350.00
Plumb Insp Deconvert Kitch/Bath	\$170.00
HVAC Above Ceiling	\$840.00
HVAC Permit Fees	\$3,355.00
HVAC Rough	\$1,440.00
HVAC Final	\$4,350.00
Insulation/Fire Stopping Inspection	\$905.00
Water Meter Upgrade Fee	\$975.00
Tap Fee	\$4,000.00
Demolition Fees	\$200.00
Dumpster/POD	\$1,150.00

Permits Issued By The Building Department

Thursday, July 1, 2021

Between: 6/1/2021 And 6/30/2021

Parkway Use	\$175.00
Parkway Inspection	\$450.00
Pre-Pour Inspection	\$2,600.00
Slab Pre-Pour	\$705.00
Stack Test	\$850.00
Pre-Pour Strt/Sdwk/Alley	\$350.00
Street Opening	\$375.00
Roof Covering Permit Fees	\$5,380.00
Roof Final Inspection	\$4,350.00
Siding Final Inspection	\$300.00
Garage Permit Fee	\$965.00
Gas Pressure Test	\$100.00
Water Pressure Test	\$100.00
Preliminary Fire Department	\$150.00
Rough Fire Department	\$300.00
Final Fire Department	\$300.00
Health Department	\$50.00
ATF Fine	\$450.00
Lintel Inspection	\$130.00
Restoration Inspection	\$350.00
As Built Drawings	\$100.00
Total Fees Collected	\$119,710.00

Permits Issued

Thursday, July 1, 2021 8:01 AM

For Period Beginning 6/1/2020 And Ending 6/30/2021

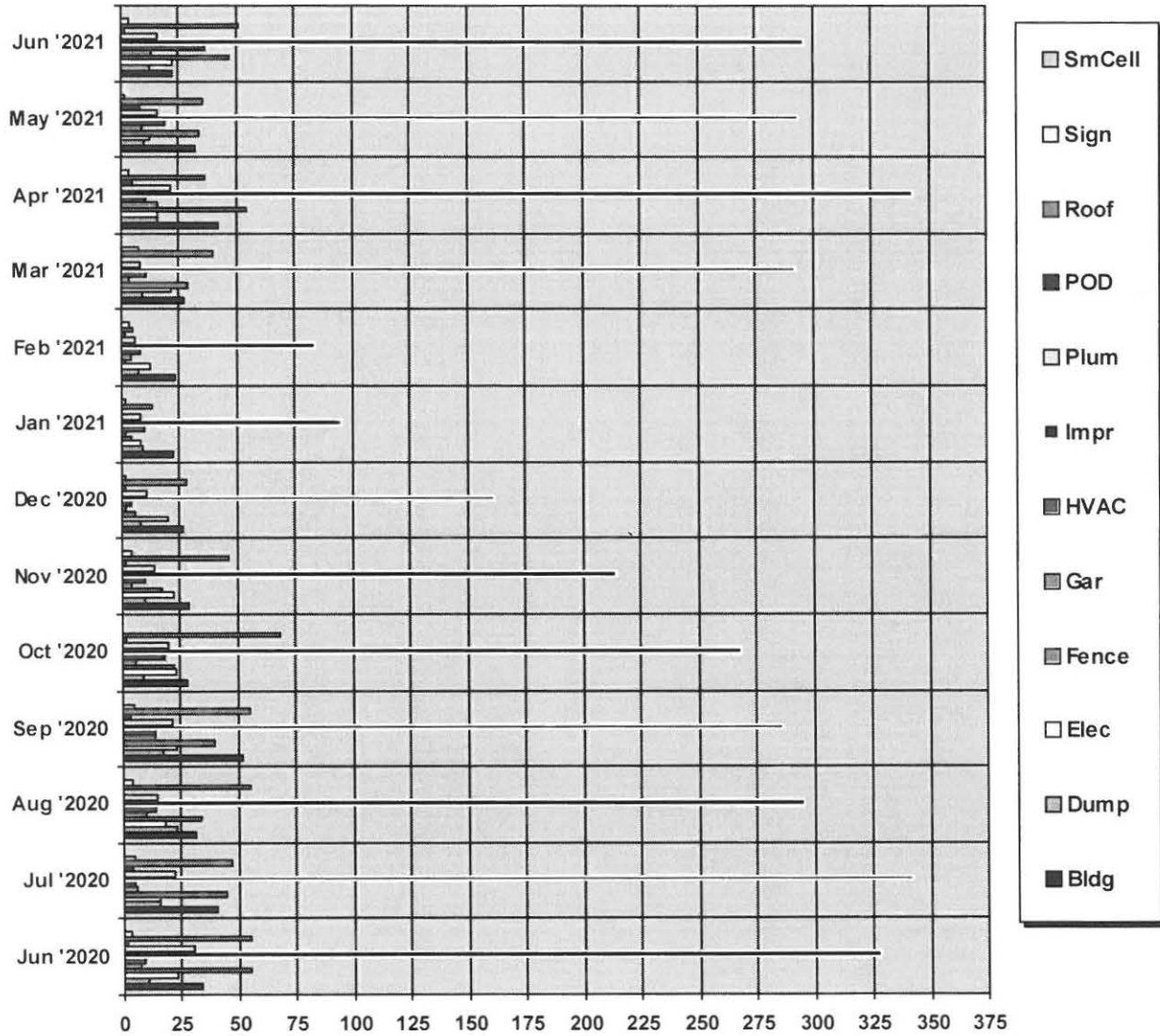

Permit Detail

2021	June	Bldg	22
		Dump	12
		Elec	22
		Fence	47
		Gar	13
		HVAC	36
		Impr	296
		Plum	16
		POD	2
		Roof	51
		Sign	3

520

2021	May	Bldg	32
		Dump	10
		Elec	12
		Fence	34
		Gar	9
		HVAC	19
		Impr	294
		Plum	16
		POD	8
		Roof	35
		Sign	2

471

Permit Detail

2021	April	Bldg	42
		Dump	16
		Elec	16
		Fence	54
		Gar	16
		HVAC	11
		Impr	343
		Plum	21
		POD	5
		Roof	36
		Sign	3

563

2020	October	Bldg	28
		Dump	9
		Elec	23
		Fence	22
		Gar	6
		HVAC	18
		Impr	268
		Plum	20
		POD	2
		Roof	68
		Sign	1

465

2021	March	Bldg	27
		Dump	9
		Elec	21
		Fence	29
		Gar	3
		HVAC	11
		Impr	292
		Plum	8
		POD	1
		Roof	39
		Sign	7

447

2020	September	Bldg	52
		Dump	17
		Elec	23
		Fence	39
		Gar	14
		HVAC	14
		Impr	286
		Plum	21
		POD	3
		Roof	55
		Sign	5

529

2021	February	Bldg	23
		Dump	7
		Elec	12
		Fence	2
		Gar	4
		HVAC	8
		Impr	84
		Plum	6
		POD	2
		Roof	5
		Sign	3

156

2020	August	Bldg	31
		Dump	23
		Elec	18
		Fence	34
		Gar	10
		HVAC	14
		Impr	295
		Plum	15
		POD	1
		Roof	55
		Sign	4

500

2021	January	Bldg	22
		Dump	9
		Elec	8
		Fence	4
		Gar	2
		HVAC	10
		Impr	95
		Plum	8
		Roof	13
		Sign	2

173

2020	July	Bldg	40
		Dump	16
		Elec	16
		Fence	44
		Gar	6
		HVAC	5
		Impr	342
		Plum	22
		POD	4
		Roof	47
		Sign	5

547

2020	December	Bldg	26
		Dump	8
		Elec	20
		Fence	6
		Gar	2
		HVAC	4
		Impr	162
		Plum	11
		POD	2
		Roof	28
		Sign	2

271

2020	June	Bldg	34
		Dump	11
		Elec	23
		Fence	55
		Gar	7
		HVAC	9
		Impr	328
		Plum	30
		POD	2
		Roof	55
		Sign	3
		SmCell	1

558

2020	November	Bldg	29
		Dump	10
		Elec	22
		Fence	17
		Gar	4
		HVAC	10
		Impr	214
		Plum	14
		POD	2
		Roof	46
		Sign	4

372

Permit Detail

Total Permits Issued **5572**

Report Of Building/Improvement Permits Issued By The City Of Berwyn

Thursday, July 1, 2021

Between: 6/1/2021 And 6/30/2021

Name and Address	P.I.N. #		Census Class	Permit Issued	Permit #	Cost Of Improvements	Cost Of Permit
1 James Hickey & Rachelle Ther	1509 S. Grove Avenue	16-19-131-005-0000	PAYING FOR PARKWAY AND RESTORATION REINSPECTIONS	R	6/1/2021 Bldg-B	9470-2	\$0.00 \$100.00
2 Adolf Vega Trust	2829 S. Ridgeland Avenue	16-29-316-015-0000	PAYING FOR ELECTRICAL ROUGH RE-INSPECTION-----INTERIOR REMODEL . 1ST FLOOR- KITCHEN, FAMILY ROOM, DINING ROOM, ADD FULL BATHROOM, 2 EXISTING BEDROOMS. 2ND FLOOR- NO WORK. BASEMENT- FINISHED WITH NEW 1/2 BATHROOM, NO BEDROOM, MECHANICAL R	R	6/1/2021 Bldg-B	9668-1	\$0.00 \$50.00
3 Triwin Investments Internationa	6948 W. 30th Street	16-30-323-004-0000	ELECTRICAL FINAL REINSPECTION-----REMODEL THE KITCHEN, REMODEL BATHROOM ON 1ST AND 2ND FLOOR EXISTING. FULLY ENCLOSED BULB LIGHTS IN BASEMENT, ELECTRICAL OUTLETS TO GFCI, SCRAP AND PAINT WHERE NEEDED, REPLACE DOOR LOCK WITH THUMBLAT	R	6/1/2021 Impr-L	88756-2	\$0.00 \$50.00
4 Jamie Rosin	6233 W. Cermak Road	16-29-102-007-0000	ROUGH FRAMING INSPECTION PRIOR TO ROUGH ELECTRICAL INSPECTION. A 2ND ROUGH FRAMING INSPECTION WILL BE REQUIRED AFTER ROUGH ELECTRICAL INSPECTION IS APPROVED.	C/R	6/1/2021 Impr-L	89880-1	\$0.00 \$140.00
5 Rodolfo Muro Ortiz & Maria Co	1308 S. Elmwood Avenue	16-19-214-024-0000	REMOVIGN AND REPLACING GARAGE OVERHEAD DOOR- SAME SIZE	R	6/1/2021 Impr-L	90616-0	\$500.00 \$40.00
6 SIP Management	1900 S. Euclid Avenue	16-19-416-046-0000	FULL TEAR OFF AND REROOF, GUTTERS AND DOWNSPOUTS, WINDOW WRAPS. SCAFFOLD	C	6/1/2021 Impr-L	90617-0	\$161,955.00 \$2,480.00
7 Miguel Gonzalez	2239 S. Highland Avenue	16-29-102-022-0000	REMOVING AND REPLACING EXISTING SIDEWALK FROM THE FRONT OF THE PROPERTY TO THE END OF THE HOUSE.	R	6/1/2021 Impr-L	90618-0	\$0.00 \$0.00

Report Of Building/Improvement Permits Issued By The City Of Berwyn

Thursday, July 1, 2021

Between: 6/1/2021 And 6/30/2021

Name and Address	P.I.N. #	Census Class	Permit Issued	Permit #	Cost Of Improvements	Cost Of Permit
8 Rosa Leon 2444 S. East Avenue	16-30-219-035-0000	R	6/1/2021 Impr-L	90619-0	\$1,500.00	\$90.00
INSTALL A NEW SIDEWALK IN FRONT OF THE HOUSE. R/R EXISTING SIDEWALKS IN FRONT OF THE PROPERTY ON SOUTH SIDE. REMOVE EXISTING SIDEWALK FLIP FLOP THE SIDEWALK AND GRASS SECTION. SIDEWALK WILL NOW BE LOCATED NEXT TO THE HOUSE AND THE GRASS SECTION WILL NOW B						
9 Berwyn Bottega Co 6714 W. Cermak Road	16-19-425-023-0000	C	6/1/2021 Impr-L	90620-0	\$6,500.00	\$155.00
ROOF REPLACEMENT. FLAT ROOF WITH NEW INSULATION NEEDS 1/2" MINIMUM INSULATION AND BASE SHEET.						
10 Gabriela Pulido 1801 S. Harvey Avenue	16-20-311-001-0000	R	6/1/2021 HVAC-L	90621-0	\$7,980.00	\$190.00
A/C REPL 13 SEER 3 TON, FURNACE REPL 80% EFF 70K BTU'S A/C 3FT FROM PROPERTY LINE. USING EXISTING CHIMNEY LINER.						
11 Luz M. Perez 1411 S. Ridgeland Avenue	16-20-115-005-0000	R	6/1/2021 HVAC-L	90622-0	\$4,450.00	\$140.00
A/C REPL 13 SEER 2.5 TON 3FT FROM PROPERTY LINE						
12 Jennifer Peskoff 1638 S. Clinton Avenue	16-19-304-034-0000	R	6/1/2021 Impr-L	90623-0	\$29,621.00	\$510.00
REMOVING AND RPELACING 36 WINDOWS TOTAL IN EXISITNG OPENINGS. 1ST FLOOR- LIVING ROOM, DINING ROOM, KITCHEN, PORCH, BATHROOM AND BEDROOMS. BASEMENT- BEDROOM, LAUNDRY, BATHROOM, LIVING ROOM. 2ND FLOOR MASTER AND DEN. GARAGE. BRING WINDOWS TO EGRESS CODE WH						
13 Vicente & Raquel Roman 2642 S. Cuyler Avenue	16-29-300-036-0000	R	6/1/2021 Impr-L	90624-0	\$0.00	\$125.00
INSTALLATION OF ABOVE GROUND POOL						
14 Ceecillia Morales & Martin Bote 1243 S. Cuyler Avenue	16-20-101-038-0000	R	6/1/2021 HVAC-L	90625-0	\$3,625.00	\$170.00
RUNNING RADIANT TO BASEMENT. INSTALLING NEW COPPER BASEBOARD IN BASEMENT .						
15 John Roussakis 2526 S. Wesley Avenue	16-30-225-024-0000	R	6/1/2021 Impr-L	90626-0	\$725.00	\$40.00
GRIND & TUCKPOINT LOOSE AND CRACKED MORTAR ON FRONT PORCH WING WALLS. CAULK STONE JOINTS AND STAIRS. IF GRINDING MUST TENT OR TARP AREA. WET GRINDING IS ALSO ALLOWED.						
16 Efrain Martinez & Daniela Eligio 3723 S. Oak Park Avenue	16-31-415-010-0000	R	6/1/2021 Impr-L	90627-0	\$1,063.00	\$40.00
REPAIR ONE FOUNDATION CRACK ON THE SOUTH WALL.						

Report Of Building/Improvement Permits Issued By The City Of Berwyn

Thursday, July 1, 2021

Between: 6/1/2021 And 6/30/2021

Name and Address	P.I.N. #	Census Class	Permit Issued	Permit #	Cost Of Improvements	Cost Of Permit
17 Forrest William & Stephanie Gr 1505 S. Grove Avenue	16-19-131-003-0000	R	6/1/2021 Impr-L	90628-0	\$0.00	\$100.00
SEWER REPAIR IN PARKWAY. WATER SERVICE REPAIR THAT WAS LEAKING.						
18 Eduardo Marinez 2715 S. Euclid Avenue	16-30-407-007-0000	R	6/1/2021 Impr-L	90629-0	\$6,400.00	\$165.00
INSTALL CONCRETE PATIO 13x26. R/R CONCRETE WALKWAY FROM ALLEY TO START OF NEW PATIO (MID-YARD).						
19 Korevia Ludington 3642 S. Highland Avenue	16-32-309-024-0000	R	6/1/2021 Impr-L	90630-0	\$1,800.00	\$40.00
REPAIR GARAGE SHINGLE TO CODE.						
20 RACHEL M. MARIE & SYNDE 2640 S. Euclid Avenue	16-30-400-033-0000	R	6/1/2021 Impr-L	90631-0	\$0.00	\$0.00
INSTALLING TEMPORARY DECK IN YARD.						
21 Refugio & Lourdes Torres 1915 S. East Avenue	16-19-420-006-0000	R	6/1/2021 Impr-L	90632-0	\$2,000.00	\$190.00
NEW 16X7 GARAGE DOOR (PARTY DOOR) AND INSTALLING NEW 17X20 CONCRETE SLAB (PATIO)						
22 Melissa J. McClelland 2637 S. Clinton Avenue	16-30-304-023-0000	R	6/1/2021 Impr-L	90633-0	\$2,000.00	\$190.00
PAINT EXTERIOR STUCCO. REPAIR FRONT PORCH/DECK. INSTALL 2 GFCI IN BATHROOM. R/R SECTION (2FT) OF GARAGE APRON. 6/2/2021 added the install of electrical baseboard heat to the basement bathroom						
23 Luis Mendoza 2430 S. East Avenue	16-30-219-040-0000	R	6/1/2021 Roof-L	90634-0	\$7,549.31	\$170.00
T/O & RE-ROOF SHINGLE ROOF ON HOUSE TO CODE. ICE & WATER SHIELD TO CODE. NO POWER VENTS. PAPER FELT, VENTS, PIPE FLASHING, & CHIMNEY FLASHING.						
24 Larry J. Denise B. Banaszak 3745 S. Wesley Avenue	16-31-417-011-0000	R	6/1/2021 Roof-L	90635-0	\$6,275.28	\$155.00
T/O & RE-ROOF HOUSE SHINGLE ROOF TO CODE. ICE & WATER SHIELD TO CODE. NO POWER VENTS.						
25 Juan M Barboza 3842 S. East Avenue	16-31-422-041-0000	R	6/1/2021 Impr-L	90636-0	\$3,000.00	\$105.00
R/R FRONT CONCRETE STAIRS W/ LANDING.						
26 Julio & Marie Barron 1310 S. Gunderson Avenue	16-19-213-030-0000	R	6/1/2021 Impr-L	90637-0	\$2,000.00	\$90.00
R/R FRONT CONCRETE APPROACH TO CODE. CONCRETE MUST PITCH TOWARDS OWN PROPERTY NOT NEIGHBOR'S OR CITY.						

Report Of Building/Improvement Permits Issued By The City Of Berwyn

Thursday, July 1, 2021

Between: 6/1/2021 And 6/30/2021

Name and Address	P.I.N. #	Census Class	Permit Issued	Permit #	Cost Of Improvements	Cost Of Permit
Juan Torres 1624 S. Wisconsin Avenue	16-19-301-027-0000	R	6/2/2021 Bldg-B	9742-2	\$0.00	\$50.00
PAYING FOR PLUMBING ROUGH RE-INSPECTION-----KITHCEN REMODEL, BASEMENT BATHROOM REMODEL, MAIN LEVEL BATHROOM REMODEL , CREATING 2 BEDROOM IN THE ATTIC, BASEMENT CONSISTS OF OFFICE, LAUNDRY ROOM, MECHANICAL ROOM, DRY BAR, EXISITNG 3/4 BATH, WITH OP						
27 Loyola University Health System	3249 S. Oak Park Avenue	16-31-215-016-0000	C	6/2/2021 Impr-L	90364-0	\$225,000.00 \$7,245.00
INTERIOR RENOVATIONS TO THE GI LAB -- WORK BEING DONE IN 4 PHASES						
28 BLACK GOLD PROPERTIES	2229 S. Clinton Avenue	16-30-102-018-0000	R	6/2/2021 Impr-L	90614-1	\$0.00 \$50.00
PRE-POUR REINSPECTION - CUT OUT AND REPLACE BROKEN SECTIONS OF CONCRETE. NO SIZE CHANGE						
29 Julio Avila	1643 S. Kenilworth Avenue	16-19-306-017-0000	R	6/2/2021 Plum-L	90638-0	\$7,750.00 \$180.00
SEWER SPOT REPAIR IN THE FRONT YARD (PRIVATE PROPERTY) & INSTALL CLEAN OUT TO CODE.						
30 George & Loverjæan Fairman	2636 S. Kenilworth Avenue	16-30-304-040-0000	R	6/2/2021 HVAC-L	90639-0	\$5,585.00 \$140.00
R/R A/C UNIT. A/C CONDENSERS MUST BE LOCATED BEHIND THE HOUSE 3' FROM PROPERTY LOT LINE AND ELECTRICAL METER.						
31 Greg Vondra	6601 W. 31st Street	16-30-418-044-0000	R	6/2/2021 Impr-L	90640-0	\$11,500.00 \$40.00
GRIND AND TUCKPOINT BASMENT WALL - REPAIR FOUNDATION CRACKS AND REPLACE CLAY TILES.						
32 Daisy Flores	1326 S. Elmwood Avenue	16-19-214-033-0000	R	6/2/2021 Dump-L	90641-0	\$50.00
DUMPSTER ON STREET. DUMPSTERS/PODS REQUIRE A FLASHING BARRICADE ON THE SIDE OF INCOMMING TRAFFIC.						
33 Severino Velazquez	6531 W. 27th Place	16-30-410-066-0000	R	6/2/2021 HVAC-L	90642-0	\$4,860.00 \$140.00
R/R A/C UNIT. A/C CONDENSERS MUST BE LOCATED BEHIND THE HOUSE 3' FROM PROPERTY LOT LINE AND ELECTRICAL METER.						
34 Bruce Johnson	2404 S. Oak Park Avenue	16-30-112-045-0000	R	6/2/2021 Roof-L	90643-0	\$14,998.83 \$275.00
TEAR OFF AND RESHINGLE THE HOUSE AND GARAGE.						
35						

Report Of Building/Improvement Permits Issued By The City Of Berwyn

Thursday, July 1, 2021

Between: 6/1/2021 And 6/30/2021

Name and Address	P.I.N. #	Census Class	Permit Issued	Permit #	Cost Of Improvements	Cost Of Permit
36 Tameeka Christian 1915 S. Wisconsin Avenue	16-19-318-006-0000	R	6/2/2021 Impr-L	90644-0	\$3,000.00	\$55.00
R/R GARAGE GUTTERS, DOWNSPOUTS, SOFFITS, FASCIAS, AND INSTALL ONE ROOF VENTS. ALL WORK ON GARAGE. DOWNSPOUTS MUST DISBURSE ONTO PRIVATE PROPERTY.						
37 Patrick Uphues & Alena Murqui 3513 S. Elmwood Avenue	16-31-409-038-0000	R	6/2/2021 Impr-L	90645-0	\$1,460.00	\$40.00
R/R GUTTERS, DOWNSPOUTS, SOFFITS, & FASCIA ON GARAGE. DOWNSPOUTS MUST DISBURSE ONTO PRIVATE PROPERTY.						
38 Ann M. & Christopher Swanson 1826 S. Cuyler Avenue	16-20-308-028-0000	R	6/2/2021 Impr-L	90646-0	\$2,650.00	\$105.00
R/R GUTTERS ON HOUSE TO CODE. DOWNSPOUTS MUST DISBURSE ONTO PRIVATE PROPERTY.						
39 Ananda M. Leinartas 1309 S. Grove Avenue	16-19-115-005-0000	R	6/2/2021 Impr-L	90647-0	\$3,370.00	\$120.00
INSTALL GUTTERS ON HOUSE & GARAGE TO CODE. DOWNSPOUTS MUST DISBURSE ONTO PRIVATE PROPERTY.						
40 Guy, Mary Ann Papa * Josephi 6538 W. 26th Street	16-30-404-090-0000	R	6/2/2021 Fence-L	90648-0	\$2,320.00	\$0.00
INSTALL A 5FT WOOD FENCE FROM THE END OF THE HOUSE TO THE END OF THE GARAGE.						
41 Sixto & Maria Lopez 3738 S. Kenilworth Avenue	16-31-321-031-0000	R	6/2/2021 Roof-L	90649-0	\$19,144.51	\$350.00
TEAR OFF AND RESHINGLE THE HOUSE.						
42 Miguel Roman 1815 S. Wesley Avenue	16-19-410-006-0000	R	6/2/2021 Roof-L	90650-0	\$7,600.00	\$170.00
T/O & RE-ROOF HOUSE FLAT ROOF TO CODE. DUMPSTERS/PODS REQUIRE A FLASHING BARRICADE ON THE SIDE OF INCOMMING TRAFFIC.						
43 Kyle J. Pullia 3723 S. Cuyler Avenue	16-32-317-042-0000	R	6/2/2021 Impr-L	90651-0	\$13,000.00	\$905.00
COMPLIANCE VIOLATION -- ATF FOR MAIN LEVEL BATHROOM REMODEL, WENT FROM SINGLE SINK TO DOUBLE SINK, CHANGED TUB PLUMBING FIXTURES, INSTALLED LIGHT AND CERAMIC TILE, HAS EXHAUST FAN. ATF FOR BASEMENT BATHROOM REMODEL - CHANGED TUC SURROUND TILES, CHANGED SH						
44 AUSRA RUPSLAUKIS 1328 S. Wisconsin Avenue	16-19-109-030-0000	R	6/2/2021 Impr-L	90652-0	\$2,000.00	\$90.00
DEMO OF BASEMENT TO STUDS. NOTHING STRUCTURAL.DUMPSTER ON STREET. DUMPSTERS/PODS REQUIRE A FLASHING BARRICADE ON THE SIDE OF INCOMMING TRAFFIC.						

Report Of Building/Improvement Permits Issued By The City Of Berwyn

Thursday, July 1, 2021

Between: 6/1/2021 And 6/30/2021

Name and Address	P.I.N. #	Census Class	Permit Issued	Permit #	Cost Of Improvements	Cost Of Permit
45 Robert & Maria Caballero 3647 S. Harvey Avenue	16-32-311-034-0000	R	6/2/2021 Fence-L	90653-0	\$5,755.00	\$135.00
46 Isela Baez 3500 S. Ridgeland Avenue	16-31-409-018-0000	R	6/2/2021 Fence-L	90654-0	\$4,198.00	\$135.00
47 Gabriel Palma 2113 S. Euclid Avenue	16-19-425-005-0000	R	6/2/2021 Impr-L	90655-0	\$620.00	\$240.00
48 Brisett Hernandez 1503 S. Highland Avenue	16-20-125-002-0000	R	6/2/2021 Impr-L	90656-0	\$3,000.00	\$105.00
49 Rigoberto Arauz 7000 W. 26th Parkway B	16-30-301-001-7001		6/2/2021 Elec-L	90657-0	\$3,800.00	\$125.00
50 Silvano Alvarez 2705 S. Clinton Avenue	16-30-312-017-0000	R	6/2/2021 Impr-L	90658-0	\$15,000.00	\$660.00
51 Ashley Merced & Yvette Nieves 1924 S. Clarence Avenue	16-19-418-023-0000	R	6/2/2021 Impr-L	90659-0	\$6,500.00	\$250.00
52 Miriam Franco & Adalberto Fra 1901 S. Clinton Avenue	16-19-321-001-0000	R	6/2/2021 Impr-L	90660-0	\$3,000.00	\$205.00
53 Desiree V. Robles & Daniel Ac 2636 S. Euclid Avenue	16-30-400-031-0000	R	6/2/2021 HVAC-L	90661-0	\$6,245.00	\$115.00

Report Of Building/Improvement Permits Issued By The City Of Berwyn

Thursday, July 1, 2021

Between: 6/1/2021 And 6/30/2021

Name and Address	P.I.N. #	Census Class	Permit Issued	Permit #	Cost Of Improvements	Cost Of Permit
54 Juana I Borrego 2314 S. Scoville Avenue	16-30-212-021-0000	R	6/2/2021 Impr-L	90662-0	\$0.00	\$140.00
COMPLIANCE VIOLATIONS - ANY OPEN BULB LIGHT FIXTURES MUST BE CONVERTED TO FULLY ENCLOSED BULB FIXTURES, ELECTRICAL OUTLETS AT BATHROOMS AND KITCHEN COUNTER MUST BE GFCI PROTECTED, KITCHEN SINK IS NOT PROPERTY VENTED AND MUST BE BROUGHT TO CODE, BASEMENT B						
54 Ramon Valladarez 1544 S. Grove Avenue	16-19-130-045-0000	R	6/3/2021 Bldg-B	9723-1	\$0.00	\$50.00
DUMPSTER ON THE STREET TO REMOVE ALL CONSTRUCTION DEBRIS. DUMPSTERS/PODS REQUIRE A FLASHING BARRICADE ON THE SIDE OF INCOMMING TRAFFIC.						
55 Cornelio & Esther Villa 2211 S. East Avenue	16-30-204-010-0000	R	6/3/2021 Impr-L	90663-0	\$500.00	\$40.00
REMOVING AND REPLACING 5 WINDOWS IN THE LIVING ROOM AND 3 IN THE DINING ROOM						
56 Linda Daniel 3648 S. East Avenue	16-31-410-039-0000	R	6/3/2021 Roof-L	90664-0	\$2,800.00	\$125.00
TEAR OFF AND REROOF HOUSE DECK, DRID EDGE, ICE AND WATER SHIELD, ARCHITECTURAL SHINGLES.						
57 Peter Estrada & Lissette Perez 1813 S. Wesley Avenue	16-19-410-005-0000	R	6/3/2021 Impr-L	90665-0	\$6,200.00	\$165.00
REPLACING 3 CASEMENT WINDOWS W/ EGRESS IN EACH BEDROOM, 1 HOPPE IN THE BASEMENT, 1 DOUBLE HUNG IN BATHROOM, 4 DOUBLE HUNGS INT HJE BEDROOMS. BRING WINDOWS TO EGRESS CODE WHERE NEEDED.						
58 Enrique & Genoveva Mellado 1808 S. Euclid Avenue	16-19-408-024-0000	R	6/3/2021 Roof-L	90666-0	\$13,366.52	\$260.00
TEAR OFF MOD BIT AND INSTALL 60 MIL FULLY ADHERED EPDM WITH COUNTER FLASHING ON BUILDING.						
59 Miriam R. Gonzalez 2522 S. Scoville Avenue	16-30-228-017-0000	R	6/3/2021 Fence-L	90667-0	\$1,000.00	\$135.00
REMOVE THE EXISTING FENCE ON THE NORTH SIDE OF THE PROPERTY FROM THE END OF THE HOUSE TO THE END OF THE GARAGE AND INSTALL A 5FT + 1 FT OPEN LATTICE FENCE - THIS FENCE WILL BE MOVE TO THE LOT LINE. - INSTALL A 6FT SOLID FENCE ALONG THE ALLEY ON THE NORTH						
60 Anthony Flores 1220 S. Oak Park Avenue	16-19-107-026-0000	R	6/3/2021 Impr-L	90668-0	\$163,656.00	\$415.00
REMOVE AND REPLACE 8'X8' REAR DECK - DECK MUST SIT ON PIERS THAT EXTEND 42" DEEP.						

61

(Building: Permit_County_All)

Report Of Building/Improvement Permits Issued By The City Of Berwyn

Thursday, July 1, 2021

Between: 6/1/2021 And 6/30/2021

Name and Address	P.I.N. #	Census Class	Permit Issued	Permit #	Cost Of Improvements	Cost Of Permit
James Anderson 3211 S. Harvey Avenue	16-32-114-006-0000	R	6/3/2021 Impr-L	90669-0	\$995.00	\$40.00
GRIND/TUCKPOINT CHIMNEY FROM ROOF UP. SPOT TUCK CHIMNEY FROM ROOF DOWN. RESEAL CAP AND FLASHING						
62 Patriot Berwyn Assoc LP 3340 S. Oak Park Avenue	16-31-127-049-0000	C	6/3/2021 Impr-L	90670-0	\$6,729.00	\$115.00
DOOR RESTRICTION ON ELEVATOR						
63 S & L Vidana 3824 S. Cuyler Avenue	16-32-324-024-0000	R	6/3/2021 Impr-L	90671-0	\$1,000.00	\$90.00
INSTALLING NEW 24X7 CONCRETE PATIO						
64 Christopher & Rachel Johl 2430 S. Gunderson Avenue	16-30-221-031-0000	R	6/3/2021 Impr-L	90672-0	\$13,165.00	\$270.00
NEW VINYL SIDING ON REAR OF PORCH AREA, INSULATE TYVEK WRAP, NEW SEAMLESS OVERSIZE GUTTERS ON THE HOUSE. 1 REAR ENTRY DOOR.						
65 AMERICAN VALUE LLC REM 2226 S. East Avenue	16-30-203-025-0000	R	6/3/2021 Impr-L	90673-0	\$1,800.00	\$165.00
EXCAVATE AND REPLACE SECTION OF PATCHED SEWER. NEW PIPING WILL BE PVC SDR-26 6" PIPE WITH CONNECTIONS MADE WITH TWO NON- SHEAR MISSION COUPLINGS.-- PARKWAY						
66 Irma Ontiveros 2108 S. Lombard Avenue	16-20-332-016-0000	R	6/3/2021 Impr-L	90674-0	\$650.00	\$40.00
R/R FASCIA AND GUTTERS AROUND THE GARAGE, ALUMINUM DOWNSPOUTS GARAGE						
67 Gerardo & Christina Diaz 2404 S. Grove Avenue	16-30-111-025-0000	R	6/3/2021 Fence-L	90675-0	\$6,000.00	\$135.00
INSTALL A NEW 5FT + 1FT OPEN LATTICE FRONT YARD FENCE BETWEEN THE 2 HOUSES ON THE SOUTH SIDE OF THIS PROPERTY- THIS FENCE MUST BE AT LEAST 15FT FROM THE FRONT LOT LINE. INSTALL AT 6FT SOLID FENCE ALONG THE ALLEY ON THE SOUTH SIDE OF THE GARAGE. - HAS PERM						
68 Luis Gonzalez & Tracy Santos 3831 S. Wisconsin Avenue	16-31-326-013-0000	R	6/3/2021 Fence-L	90676-0	\$13,000.00	\$135.00
REMOVE THE FENCE ON THE NORTH SIDE OF THE PROPERTY (HAS PERMISSION FROM 3829 WIS) AND INSTALL A 5FT + 1 FT OPEN LATTICE METAL POST (NO SHARP POINTS) AND WOOD PANEL FENCE FROM THE A FEW FT PAST THE REAR OF THE HOUSE TO THE ALLEY. REMOVE THE FENCE ON THE SO						
69 Jesus Valle-Garcia & Antonio V 1630 S. Euclid Avenue	16-19-400-027-0000	R	6/3/2021 Impr-L	90677-0	\$4,000.00	\$145.00
REMOVE AND REPLACE DAMAGED BRICKS WHERE NEEDED ON THE HOUSE AND GARAGE AND TUCKPOINT. REPLACE MISSING SECTION OF FASCIA.						
70						

Report Of Building/Improvement Permits Issued By The City Of Berwyn

Thursday, July 1, 2021

Between: 6/1/2021 And 6/30/2021

Name and Address	P.I.N. #	Census Class	Permit Issued	Permit #	Cost Of Improvements	Cost Of Permit
R & I Real Estate Investments 3240-42 S. Oak Park Avenue	16-31-127-028-0000	C	6/4/2021 Bldg-B	9362-2	\$0.00	\$200.00
PAYING FOR INSPECTION FEES. 2 PLUMBING FINAL INSPS, ELECTRICAL ROUGH AND WATER PRESSURE TEST.						
71 Merriment Homes Inc. 2626 S. Kenilworth Avenue	16-30-304-036-0000		6/4/2021 Bldg-B	9631-1	\$0.00	\$50.00
PAYING FOR THE ADDITIONAL PRE-POUR INSPECTION FOR THE SIDEWALK AND CURB.						
72 Earl Lafin 2229 S. East Avenue	16-30-204-018-0000	R	6/4/2021 Elec-L	90180-1	\$0.00	\$50.00
ELECTRICAL REINSPECTION -- R/R 1 METER SOCKET, INSTALL GROUND ROD, REPLACE 3 RECEPTACLES, INSTALL 1 LIGHT						
73 John & Mollie Scott 3643 S. Kenilworth Avenue	16-31-314-009-0000	R	6/4/2021 Plum-L	90320-1	\$0.00	\$150.00
PAYING FOR PLUMBING UNDERGROUND PVS INSTALLATION, BEDDING AND HEAD TEST.						
74 Berwyn Plaza LLC 6901 W. Ogden Avenue	16-31-305-044-0000	C	6/4/2021 Impr-L	90678-0	\$76.00	\$90.00
INSTALLATION FO NAPCA FIRE RADIO TOE TO EXISTING FIRE ALARM SYSTEM.						
75 Robert Kaucky (O) 2605 S. Ridgeland Avenue	99-99-999-000-0541		6/4/2021 Sign-L	90679-0	\$3,490.00	\$170.00
INTERNALLY ILLUMINATED LIGTH BOX 2FT X 1IN. WILL BE INSTALLED ON THE WALL AT THE MAIN ENTRANCE .						
76 Andra Degante Flores 1248 S. Lombard Avenue	16-20-103-039-0000	R	6/4/2021 Impr-L	90680-0	\$500.00	\$40.00
COMPLIANCE VIOLATION - ALL BASEMENT WINDOWS ARE BOARDED UP, ALL BOARD UP PLYWOOD MUST BE REMOVED AND BASEMENT WINDOWS MUST ALL BE REPAIRED/REPLACED TO CODE, REPAIR ALL CLOSET DOORS AS NEEDED, EXTERIOR PREMISES MUST BE MAINTAINED FREE OF WEEDS, OVERGROWN G						
77 John E. Bomher 6519 W. 26th Street	16-30-229-037-0000	C/R	6/4/2021 Impr-L	90681-0	\$11,250.00	\$390.00
INSTALLATION OF A FIRE ALARM SYSTEM						
78 Paul & Jacklyn Alvarez 2836 S. Harvey Avenue	16-29-318-036-0000	R	6/4/2021 Impr-L	90682-0	\$2,000.00	\$90.00
EXTEND EXISTING PATIO BY 6FT IN WIDTH. CONCRETE MUST PITCH TOWARDS OWN PROPERTY NOT NEIGHBOR'S OR CITY.						
79 Thomas J. & Vivian Nimietz 2641 S. Grove Avenue	16-30-306-020-0000	R	6/4/2021 Impr-L	90683-0	\$19,152.00	\$360.00
INSTALLATION OF ROOFTOP SOLAR PANELS. MUST HAVE TAP CONNECTORS						
80 Alfonso Reyes & Migdalia Rey 2434 S. East Avenue	16-30-219-025-0000	R	6/4/2021 Impr-L	90684-0	\$16,416.00	\$315.00
INSTALLATION OF ROOF TOP SOLAR PANELS - NEW ELECTRICAL METER -- MUST HAVE TAP CONNECTORS.						

81

Report Of Building/Improvement Permits Issued By The City Of Berwyn

Thursday, July 1, 2021

Between: 6/1/2021 And 6/30/2021

Name and Address	P.I.N. #	Census Class	Permit Issued	Permit #	Cost Of Improvements	Cost Of Permit
Antonio Lopez 1613 S. Ridgeland Avenue	16-20-300-007-0000	R	6/4/2021 Impr-L	90685-0	\$6,840.00	\$165.00
INSTALLATION OF ROOFTOP SOLAR PANELS - NEED NEW ELECTRICAL METER - MUST HAVE TAP CONNECTORS.						
82 Maura Waldron & Joseph Carm 1239 S. Kenilworth Avenue	16-19-106-024-0000	R	6/4/2021 Elec-L	90686-0	\$975.00	\$90.00
INSTALL 240 VOLT ELECTRICAL LINE						
83 Ernest & Pernee Herdle 1824 S. Wisconsin Avenue	16-19-309-030-0000	R	6/4/2021 HVAC-L	90687-0	\$4,985.00	\$140.00
A/C REPL 13 SEER 3 TON 3FT FROM PROPERTY LINE.						
84 Francisca Sanchez Maceda & 6417 W. 26th Street	16-30-231-035-0000	R	6/4/2021 Elec-L	90688-0	\$400.00	\$90.00
INSTALL SIMPLEX OUTLET FOR GARAGE DOOR OPENER, LABEL BREAKERS, REPLACE TWO PRONG OUTLETS WITH THREE PRONGS, REPLACE LAUNDRY OUTLET WITH GFCI						
85 Alexander & Teresa Antonio 2121 S. Harvey Avenue	16-20-332-008-0000	R	6/4/2021 Impr-L	90689-0	\$400.00	\$40.00
ATF- GARAGE OVERHEAD REPLACEMENT						
86 Cathleen Knobbe 2641 S. Clinton Avenue	16-30-304-025-0000	R	6/4/2021 Impr-L	90690-0	\$5,000.00	\$235.00
REMOVE TUB AND REPLACE WITH WALK-IN SHOWER ON THE 1ST FLOOR, R/R KITCHEN SINK, R/R KITCHEN COUNTERTOPS-CABINET DOORS ONLY AND EPOXY THE COUNTERTOP ONLY. NO DRYWALL						
87 Jaya Chitta & Revathi Jangiti 3109 S. Clarence Avenue	16-31-203-004-0000	R	6/4/2021 Impr-L	90691-0	\$7,524.00	\$180.00
INSTALLATION OF ROOFTOP SOLAR PANELS, ELECTRICAL SERVICE MUST BE BROUGHT TO CODE.						
88 Felicity & George Rodriguez 3514 S. Wisconsin Avenue	16-31-301-020-0000	R	6/4/2021 Fence-L	90692-0	\$4,028.00	\$135.00
R/R FENCE FROM REAR OF HOUSE TO GARAGE ON THE NORTH SIDE OF PROPERTY 6FT TALL.						
89 Yolanda Lopez Madrid & Steph 2530 S. Oak Park Avenue	16-30-117-030-0000	R	6/4/2021 HVAC-L	90693-0	\$17,775.55	\$190.00
R/R FURNACE AND A/C UNIT. A/C CONDENSERS MUST BE LOCATED BEHIND THE HOUSE 3' FROM PROPERTY LOT LINE AND ELECTRICAL METER.						
90 Jeremy & Shelia Daugherty 2213 S. Kenilworth Avenue	16-30-103-011-0000	R	6/4/2021 Impr-L	90694-0	\$800.00	\$190.00
OPEN BULBS IN BASEMENT TO FULLY ENCLOSED, BEDROOM OUTLETS 3, REINFORCE HANDRAILS, GFCI SWITCHES INSTALLED IN BASEMENT, REPLACE COVER OUTLETS, REPAIR FLOOR BOARD IN ATTIC, REINFORCE LANDING AREA, REPLACE PLASTIC WATER SUPPLY HOSES, INSTALL SIMPLEX TYPE OUT						

91

Report Of Building/Improvement Permits Issued By The City Of Berwyn

Thursday, July 1, 2021

Between: 6/1/2021 And 6/30/2021

Name and Address	P.I.N. #	Census Class	Permit Issued	Permit #	Cost Of Improvements	Cost Of Permit
Adelaida Alvarado 6533 W. Cermak Road	16-30-204-007-0000	C	6/4/2021 Impr-L	90695-0	\$7,700.00	\$180.00
REMOVING EXISTING ALUMINUM AND GLASS AND WILL BE INSTALLING THE DOOR AND PANELS. 1 DOOR 46"X100 WITH TRANSOM, 2 PANELS 40"X100" , 4 PANELS 65"X100". 1/4 CLEAR TEMPER GLASS.						
92 Three Brothers, LLp 6412 W. 37th Street	16-31-419-032-0000	R	6/4/2021 Impr-L	90696-0	\$750.00	\$90.00
INSTALL AN EGRESS WINDOWS IN THE 2ND FLOOR BEDROOM TO CODE.						
93 Vanessa & Ambrosio Zaragoza 1613 S. East Avenue	16-19-404-006-0000	R	6/4/2021 Roof-L	90697-0	\$7,500.00	\$170.00
TEAR OFF AND REROOF WITH NEW SHINGLES ON THE HOUSE, ICE AND WATER SHIELD, FELT PAPER, FLASHING AT CHIMNEY.						
94 2125 S HARLEM, LLC 2125 S. Harlem Avenue	16-19-324-046-0000	R	6/4/2021 Impr-L	90698-0	\$11,000.00	\$120.00
REMOVE OLD GUTTER SYSTEM, INSTALL NEW 5K GUTTER AND 3X4 DOWNSPOUT.						
95 3051 S. Harlem, LLC 3051 S. Harlem Avenue	16-30-320-037-0000		6/4/2021 Impr-L	90699-0	\$11,000.00	\$120.00
REMOVE OLD GUTTER SYSTEM, INSTALL NEW 5K GUTTER AND 3X4 DOWNSPOUT						
96 3053 S. HARLEM, LLC 3053 S. Harlem Avenue	16-30-320-038-0000	C	6/4/2021 Impr-L	90700-0	\$11,000.00	\$120.00
REMOVE OLD GUTTER SYSTEM, INSTALL NEW 5K GUTTER AND 3X4 DOWNSPOUT						
97 Alfredo Perez 1325 S. Clarence Avenue	16-19-211-019-0000	R	6/4/2021 Impr-L	90701-0	\$0.00	\$0.00
PRELIMINARY ELECTRICAL INSPECTION TO DETERMINE LOCATION OF CONDUIT						
98 Victor M. Ramirez 1826 S. Clinton Avenue	16-19-312-031-0000	R	6/4/2021 Impr-L	90702-0	\$500.00	\$240.00
DEMO A WALL TO CREATE A LARGER BEDROOM, DEMO THE ARCH WALLS IN THE LIVING ROOM AND BACK KITCHEN, R/R DRYWALL ON WALLS WHERE NEEDED AND RELOCATE ELECTRIC BASED OFF THE WALLS BEING DEMO'ED.						
99 Kristin N. Bush 1220 S. Maple Avenue	16-19-100-027-0000	R	6/4/2021 Plum-L	90703-0	\$1,769.00	\$90.00
REMOVE/REPLACE DRUM TRAP. CONNECTING IT TO THE EXISTING 2" GALVANIZED DRAIN.						
100 JAMES LESTER PRICE 3707 S. Grove Avenue	16-31-323-003-0000	R	6/4/2021 Impr-L	90704-0	\$2,486.00	\$40.00
R/R GARAGE OVERHEAD DOOR - SAME SIZE.						
101 M. & E. Lopez 2615 S. Grove Avenue	16-30-306-010-0000	R	6/4/2021 Impr-L	90705-0	\$1,200.00	\$90.00
R/R THE SIDEWALK BEHIND THE HOUSE AND EXTEND SIDEWALK TO THE EXISTING PATIO. 6/23/2021 ADDING THE REPLACEMENT OF 5 BACK PORCH WINDOWS						

102

Report Of Building/Improvement Permits Issued By The City Of Berwyn

Thursday, July 1, 2021

Between: 6/1/2021 And 6/30/2021

Name and Address	P.I.N. #	Census Class	Permit Issued	Permit #	Cost Of Improvements	Cost Of Permit
Jorge & Myrian Garcia 2105 S. East Avenue	16-19-428-002-0000	R	6/4/2021 Impr-L	90706-0	\$900.00	\$90.00
CONCRETE PATIO - REPAIR THE EXISTING CONCRETE SIDEWALK IN THE BACK YARD NEXT TO THE BUILDING AND ADD A 24'X10' SECTION OF CONCRETE. MASONRY REPAIRS TO THE WESTSIDE OF THE GARAGE AND TUCKPOINT THE EXTERIOR GARAGE WALLS.						
103						
Edwin Molina & Cecilia Trujillo 2646 S. Clarence Avenue	16-30-402-038-0000	R	6/4/2021 Fence-L	90707-0	\$0.00	\$135.00
R/R FENCE FROM REAR OF HOUSE TO END OF GARAGE ON THE SOUTH SIDE OF PREOPERTY 5FT+1FT OPEN LATTICE. R/R FENCE FROM REAR OF HOUSE TO END OF GARAGE ON THE NORTH SIDE OF PROPERTY 5FT+1FT OPEN LATTICE (HAS NEIGHBOR PERMISSION FROM 2644 CLARENCE). JULIE DIG#						
104						
The Smith Family Revocable Li 1242 S. Grove Avenue	16-19-106-043-0000	R	6/4/2021 Impr-L	90708-0	\$300.00	\$150.00
DEMO AND REBUILD THE STAIRS - LANDING TO REMAIN -- STAIRS MUST BE ON 42" DEEP PIERS.						
105						
Lori & Derek Janu-Chossek 1347 S. Cuyler Avenue	16-20-108-017-0000	R	6/4/2021 Plum-L	90709-0	\$0.00	\$85.00
R/R WATER HEATER - WATER HEATERS REQUIRE EXPANSION TANKS.						
106						
Jim Hagen and Donald S. Marv 3218 S. Wisconsin Avenue	16-31-109-023-0000	R	6/4/2021 Impr-L	90710-0	\$2,000.00	\$40.00
REMOVING AND REPLACING 3 TOTAL WINDOWS. IN THE GARAGE, KITCHEN WINDOW AND 3RD FLOOR						
107						
Leticia Uribe & L. Bacilisa 2522 S. Ridgeland Avenue	16-30-231-023-0000	R	6/4/2021 Fence-L	90711-0	\$0.00	\$135.00
RMEOVIGN AND REPLACING EXISTING FENCE FROM REAR OF HOUSE TO THE ALLEY 6FT CHAIN LINK FENCE						
108						
Molly J. Masters & Nicholas G. 3205 S. Wisconsin Avenue	16-31-110-002-0000	R	6/7/2021 Gar-B	9761-0	\$29,500.00	\$325.00
DEMO AND REBUILD A 24'X22' 12'8" (H) GARAGE.						
109						
Gerardo Roman 2318 S. Highland Avenue	16-29-109-028-0000	R	6/7/2021 Bldg-B	9762-0	\$10,200.00	\$405.00
INSTALL BOILERS TO FORCED AIR WITH NEW FURNACE, DUCTWORK AND A/C UNIT. A/C CONDENSERS MUST BE LOCATED BEHIND THE HOUSE 3' FROM PROPERTY LOT LINE AND ELECTRICAL METER. ALL BEDROOMS REQUIRE A RETURN.						
110						

Report Of Building/Improvement Permits Issued By The City Of Berwyn

Thursday, July 1, 2021

Between: 6/1/2021 And 6/30/2021

Name and Address	P.I.N. #		Census Class	Permit Issued	Permit #	Cost Of Improvements	Cost Of Permit
111 Errol McLendon & Wendy Clare 1411 S. Wenonah Avenue	16-19-119-005-0000	DEMO EXISTING GARAGE 12X18 FRAME, SLAB, APRON AND 2X18 WALK. NEW 19X20 GARAGE, FRAME CONCRETE SLAB AND 5' APRON.	R	6/7/2021 Gar-B	9763-0	\$24,235.00	\$325.00
112 Alison N Teague 3812 S. Ridgeland Avenue	16-31-424-063-0000	REMOVE CONCRETE SLAB 14X22, APRON 5' AND WALK 3X6. NEW GARAGE FRAME 18X22, CONCRETE SLAB 18X22 APRON 18X3 AND WALK 3X6	R	6/7/2021 Gar-B	9764-0	\$21,850.00	\$300.00
113 Cynthia Orrico 6921 W. 30th Place	16-30-323-026-0000	R/R FRONT STEPS AND APPROACH - REINSTALL EXISTING HANDRAIL. CONCRETE MUST PITCH TOWARDS OWN PROPERTY NOT NEIGHBOR'S OR CITY.	R	6/7/2021 Impr-L	90712-0	\$5,985.00	\$150.00
114 KARRAH CULLERS 2938 S. Oak Park Avenue	16-30-319-030-0000	ATF - BASEMENT REMODEL TO INCLUDE AN OPEN RECREATIONAL SPACE AND AN AREA FOR A FUTURE BATHROOM THAT WILL BE USED AS STORAGE FOR RIGHT NOW. INSTALL WINDOWS TO EGRESS CODE. EXTEND DUCT WORK	R	6/7/2021 Impr-L	90713-0	\$1,400.00	\$450.00
115 Luis H. Treto 1336 S. Euclid Avenue	16-19-208-037-0000	DUMPSTER TO BE ON THE STREET. DUMPSTERS/PODS REQUIRE A FLASHING BARRICADE ON THE SIDE OF INCOMMING TRAFFIC.	R	6/7/2021 Dump-L	90714-0	\$0.00	\$50.00
116 Loyola University Health Syste 3249 S. Oak Park Avenue	16-31-215-016-0000	EXPANSION OF AN EXISTING FIRE ALARM SYSTEM TO ACCOMMODATE BASEMENT AND PENTHOUSE RENOVATIONS (FOR PHARMACY)	C	6/7/2021 Impr-L	90715-0	\$4,600.00	\$285.00
117 Veronica Serna Jimenez 1339 S. Cuyler Avenue	16-20-108-015-0000	TEAR OFF AND RESHINGLE THE HOUSE.	R	6/7/2021 Roof-L	90716-0	\$8,500.00	\$185.00
118 Michael Hannah 1340 S. Ridgeland Avenue	16-19-215-040-0000	POD CONTAINER TO BE ON THE STREET- MOVING OUT. DUMPSTERS/PODS REQUIRE A FLASHING BARRICADE ON THE SIDE OF INCOMMING TRAFFIC.	R	6/7/2021 POD-L	90717-0	\$0.00	\$50.00
119 Ralph Householder 3816 S. Lombard Avenue	16-32-327-034-0000	INSTALLING EGRESS WINDOW TO CODE. STORAGE POD TO BE PUT ON THE STREET.	R	6/7/2021 Impr-L	90718-0	\$500.00	\$100.00

Report Of Building/Improvement Permits Issued By The City Of Berwyn

Thursday, July 1, 2021

Between: 6/1/2021 And 6/30/2021

Name and Address	P.I.N. #	Census Class	Permit Issued	Permit #	Cost Of Improvements	Cost Of Permit
120 Milan Savic 2513 S. Euclid Avenue	16-30-225-005-0000	R	6/7/2021 Impr-L	90719-0	\$420.00	\$40.00
GRIND UT LOOSE AND CRACKED MORTAR JOINTS ON WING WALL AS NEEDED AND SPOT TUCK POINT W/ COMPATIBLE COLO RMORTAR, RESET LOOSE FOOT STONE ON BOTTOM OF SOUTH WING WALL, GRIND OUT LOOSE AND CRACKED MORTAR JOINTS NEAR THE GAS METER AND AROUND THE FRONT GLASS BL						
121 Richard & Carol Vitacca 2839 S. Cuyler Avenue	16-29-317-017-0000	R	6/7/2021 Impr-L	90720-0	\$3,795.00	\$245.00
DEMO AND REBUILD CHIMNEY TO SAME HEIGHT. INSTALL NEW CHIMNEY CAP AND LINER. TUCKPOINT CHIMNEY FROM ROOF DOWN, SPOT TUCKPOINT LARGE CRACKS ON FRONT OF HOUSE.						
121 Sibyl Krucoff 3226 S. Clarence Avenue	16-31-217-020-0000	R	6/7/2021 Impr-L	90721-0	\$3,600.00	\$145.00
GRIND AND TUCKPOINT ENTIRE CHIMNEY. RESEAL CAP AND FLASH SPOT TUCKPOINT HOUSE.						
122 Maria J. & Victor A. Barahona 1303 S. Clarence Avenue	16-19-211-012-0000	R	6/7/2021 Impr-L	90722-0	\$16,012.00	\$315.00
INSTALL PV ROOFTOP SOLAR MODULES						
123 Casimir Gorski 3819 S. Maple Avenue	16-31-325-008-0000	R	6/7/2021 Impr-L	90723-0	\$1,600.00	\$50.00
REPLACING RUSTED IRON RAILING ON FRONT STAIRS WITH RUST FREE ALUMINUM RAILING						
124 Victor & Pauline Hernandez 7120 W. 26th Street	16-30-327-006-0000	R	6/7/2021 Roof-L	90724-0	\$20,735.00	\$365.00
TEAR OFF AND REROOF ON THE HOUSE- FLAT ROOF						
125 Manohar Jethani 3635 S. Harlem Avenue	16-31-308-055-0000	C	6/7/2021 Sign-L	90725-0	\$9,500.00	\$260.00
REPLACING EXISTING POLE SIGN AND ADDING A NEW 2 SIDED LED SIGN 2X8- ELECTRICAL EXISTS						
126 Luis Alberto Restrepo 1402 S. Clinton Avenue	16-19-120-020-0000	R	6/7/2021 Roof-L	90726-0	\$600.00	\$125.00
REMOVING AND REPLACING ROOF ON THE HOUSE (SOUTH SIDE) SHINGLES, FELT PAPER, ICE AND WATER SHIELD						
127 David & Adriana Martinez 6439 W. 33rd Street	16-31-220-031-0000	R	6/7/2021 Impr-L	90727-0	\$0.00	\$0.00
PRE-POOL INSPECTION TO DETERMINE IF LOCATION OF ABOVE GROUND POOL WILL BE TO CODE.						
128 Antoinette Rosario 3629 S. Scoville Avenue	16-31-412-012-0000	R	6/7/2021 Roof-L	90728-0	\$13,089.01	\$245.00
TEAR OFF AND RESHINGLE THE HOUSE.						
129						

Report Of Building/Improvement Permits Issued By The City Of Berwyn

Thursday, July 1, 2021

Between: 6/1/2021 And 6/30/2021

Name and Address	P.I.N. #	Census Class	Permit Issued	Permit #	Cost Of Improvements	Cost Of Permit
David & Duselina Alcacio 3624 S. Lombard Avenue 130	16-32-311-013-0000	R	6/7/2021 Impr-L	90729-0	\$1,850.00	\$140.00
INSTALL EGRESS WINDOW TO CODE IN THE BASEMENT RECREATIONAL ROOM AND 2ND FLOOR BEDROOM. REPAIR ELECTRIC IN GARAGE						
Raul & Salvador Casillas 2119 S. Harvey Avenue 131	16-20-332-007-0000	R	6/7/2021 Impr-L	90730-0	\$1,013.00	\$40.00
REMOVING AND REPLACING GARAGE OVERHEAD DOOR- SAME SIZE.						
IL Property Solutions LLC 3739 S. Harvey Avenue	16-32-319-033-0000	R	6/8/2021 Bldg-B	9715-2	\$0.00	\$50.00
ELECTRICAL ROUGH RE-INSPECTION - 1ST FLR: KITCHEN, LIVING ROOM, FULL EXISTING BATH, TWO BEDROOMS. BSMT: FINISHED, EXISTING 3/4 BATH, 1 EXISTING BEDROOM, LAUNDRY ROOM, MECHANICAL ROOM. TWO BATHROOM REMODELS (TILES & FIXTURES), KITCHEN REMODEL (TILES & FIXT						
Pilsen-Little Village Mental Heal 2600 S. Ridgeland Avenue 132	16-30-404-023-0000	C	6/8/2021 Bldg-B	9766-0	\$500,000.00	\$8,850.00
REMODEL 2 BATHROOMS, R/R WINDOWS, ADDING AN ELEVATOR AND POURING NEW CONCRETE. DUMPSTERS/PODS REQUIRE A FLASHING BARRICADE ON THE SIDE OF INCOMMING TRAFFIC.						
Brian A. Vazzana & Veronica M 1831 S. Euclid Avenue 133	16-19-409-014-0000	R	6/8/2021 Elec-L	90731-0	\$285.00	\$90.00
COMPLIANCE- ELECTRIC ONLY. REPLACING 2 PRONG OUTLET IN GARAGE TO GFCI, REPLACE DUPLEX OUTLET FOR GARAGE DOOR OPENER WITH 15 AMP SIMPLEX OUTLET.						
Milan Fink 1302 S. Wenonah Avenue 134	16-19-110-019-0000	R	6/8/2021 Impr-L	90732-0	\$500.00	\$90.00
REPLACING WOOD STAIRS IN THE BACK OF THE HOUSE. PER CDL OK TO LAG BOLT TO CONCRETE						
Joseph & Bridget LaPietra 3738 S. Clarence Avenue 135	16-31-417-037-0000	R	6/8/2021 Impr-L	90733-0	\$7,500.00	\$180.00
REPLACING REAR STEPS, INCLUDING 12' OF RETAINING WALL						
Jaime Torres & Liliانا Torres 6520 W. Pershing Road 136	16-31-423-105-0000	R	6/8/2021 Impr-L	90734-0	\$1,500.00	\$190.00
GROUND LEVEL DECK 20 1/2" OFF GROUND WITH HOT TUB AND ROOFED OVER PATIO. OK PER CDL FOR ROOFED OVER PATIO TO BE LAG BOLTED TO EXISTING CONCRETE. OUTLET EXISTS.						
John & Sylvia Alvarado 2526 S. Scoville Avenue 137	16-30-228-019-0000	R	6/8/2021 Impr-L	90735-0	\$600.00	\$40.00
REMOVIGN AND REPLACING AWNING ON THE GARAGE, SIDE OF PROPERTY AND IN FRONT OF PROPERTY						
138						

Report Of Building/Improvement Permits Issued By The City Of Berwyn

Thursday, July 1, 2021

Between: 6/1/2021 And 6/30/2021

Name and Address	P.I.N. #	Census Class	Permit Issued	Permit #	Cost Of Improvements	Cost Of Permit
139 Ramirez & Becerra 2213 S. Highland Avenue	16-29-102-011-0000	R	6/8/2021 Impr-L	90736-0	\$3,905.00	\$140.00
	A/C REPL 13 SEER 2.5 TON 3FT FROM PROPERTY LINE.					
140 Maria D. Leon 1303 S. Harvey Avenue	16-20-110-002-0000	R	6/8/2021 Plum-L	90737-0	\$11,500.00	\$315.00
	EMERGENCY- SEWER REPAIR PARKWAY INSTALLING CLEAN OUT STATION (ON PRIVATE PROPERTY)					
141 SUSANA URQUIZA 2410 S. East Avenue	16-30-219-017-0000	R	6/8/2021 Impr-L	90738-0	\$4,101.00	\$135.00
	R/R 2 BEDROOM WINDOWS AND R/R 2 BATHROOM WINDOWS. ----- 2 EGRESS					
142 3200 Lake Shore LLC 1927 S. Euclid Avenue	16-19-417-036-0000	C	6/8/2021 Impr-L	90739-0	\$300.00	\$75.00
	REBUILD THE BRICK WALLS WHERE MISSING AND COLLAPSED ON THE GARAGE.					
143 James Vondra 1243 S. Harvey Avenue	16-20-103-024-0000	R	6/8/2021 Impr-L	90740-0	\$0.00	\$40.00
	REMOVING AND REPLACING EXISTING SIDEWALK IN THE BACKYARD					
144 Adam S. Gonzalez & Marisol A 3532 S. Wenonah Avenue	16-31-302-029-0000	R	6/8/2021 Roof-L	90741-0	\$7,000.00	\$155.00
	REMOVE AND REPLACE ROOF ON THE HOUSE NAD GARAGE WITH SHINGLES , ICE AND WATER SHIELD, FELT, ROOF VENTS					
145 Lurdes A. Llapa 3416 S. East Avenue	16-31-233-018-0000	R	6/8/2021 Fence-L	90742-0	\$6,700.00	\$135.00
	REMOVIGN AND REPLACING FENCE ON THE SOUTH SIDE OF THE PROPERTY FROM REAR OF HOUSE WITH A GATE TO THE REAR OF PROPERTY . FENCE WILL BE 5FT+1FT OPEN LATTICE. JULIE DIG# ATTACHED. (HAS NEIGHBOR PERMISSION)					
146 First Rate Properties 6405 W. 34th Street B	99-99-999-000-0696		6/8/2021 Impr-L	90743-0	\$1,500.00	\$290.00
	BUILDING 2 WALLS TO CREATE CONFERENCE ROOM.---- FUTURE MODIFICATION TO EXISTING FIRE ALARM. MUST ADD CONTRACTOR TO PERMIT BEFORE ANY WORK CAN BE DONE.					
147 Maria Garcia 1520 S. Oak Park Avenue	16-19-131-031-0000	R	6/8/2021 Impr-L	90744-0	\$10,944.00	\$225.00
	INSTALLATION OF ROOFTOP SOLAR PANELS, REPLACEMENT OF METER ENCLOSURE, AND SERVICE ENTRANCE CONDUCTORS. METER NEEDS TO BE REPLACED. MUST HAVE TAP CONNECTORS.					
148 John & Ana Fuentes 1523 S. East Avenue	16-19-228-011-0000	R	6/8/2021 Impr-L	90745-0	\$10,944.00	\$225.00
	INSTALLATION OF ROOFTOP SOLAR PANELS AND REPLACEMENT OF METER ENCLOSURE TO ALLOW FOR METER LUG ADAPTER INTERCONNECTION. MUST HAVE TAP CONNECTORS.					

Report Of Building/Improvement Permits Issued By The City Of Berwyn

Thursday, July 1, 2021

Between: 6/1/2021 And 6/30/2021

Name and Address	P.I.N. #	Census Class	Permit Issued	Permit #	Cost Of Improvements	Cost Of Permit
149 Edgar Alas 1940 S. Cuyler Avenue	16-20-321-029-0000	R	6/8/2021 Fence-L	90746-0	\$6,460.00	\$185.00
R/R FENCE ON THE SOUTH SID EOF PROPERTY FROM REAR OF HOUSE TO THE GARAGE (SOUTH SIDE) 5FT+1FT OPENLATTICE. INSTALLING FENCE/GATE FROM HOUSE TO HOUSE 5FT+1FT LATTICE AND GARAGE TO GARAGE 6FT SOLID ON THE NORTH SIDE OF PROPERTY. (FENCE CONNECTION TO DO) HA						
149 Henry Gonzalez & Leticia Vazq 3702 S. Wesley Avenue	16-31-416-021-0000	R	6/8/2021 Impr-L	90747-0	\$0.00	\$50.00
DUMPSTER TO BE ON THE STREET. DUMPSTERS/PODS REQUIRE A FLASHING BARRICADE ON THE SIDE OF INCOMMING TRAFFIC.						
150 Dorothy Ann Lyssendo 3826 S. Wenonah Avenue	16-31-326-024-0000	R	6/8/2021 HVAC-L	90748-0	\$9,836.00	\$190.00
R/R FURNACE AND A/C UNIT. A/C CONDENSERS MUST BE LOCATED BEHIND THE HOUSE 3' FROM PROPERTY LOT LINE AND ELECTRICAL METER.						
151 Nello and Frances Parrillo 1240 S. Highland Avenue	16-20-101-033-0000	R	6/8/2021 Impr-L	90749-0	\$1,000.00	\$40.00
SEAL CRACK BETWEEN SIDEWALK & FOUNDATION WITH SEALANT.						
152 Chicago Title #800236360 6214 W. 35th Street	16-32-303-042-0000	R	6/8/2021 Impr-L	90750-0	\$950.00	\$40.00
TUCKPOINT CHIMNEY						
153 Randy & Maria Allori 2408 S. Wesley Avenue	16-30-217-020-0000	R	6/8/2021 Impr-L	90751-0	\$1,500.00	\$90.00
R/R CONCRETE YARD SIDEWALK FROM ALLEY TO BACK OF HOUSE AND RELOCATE TO THE NORTH OF FENCE LINE. ADDING NEW CONCRETE PATIO TO TIE INTO SIDEWALK 11*21. JULIE CALLED.						
154 Mariana Vazquez 7014 W. 16th Street	16-19-303-002-0000	R	6/8/2021 Impr-L	90752-0	\$500.00	\$140.00
CREATE A NEW WALL ON THE INSIDE OF THE STAIRWELL TO CREATE PRIVACY- THE WALL WILL NOT GO ALL THE WAY UP TP THE CEILING.						
155 Maribel Zapata 3807 S. East Avenue	16-31-423-002-0000	R	6/8/2021 Impr-L	90753-0	\$2,500.00	\$0.00
REMOVE SIDING AND INSTALL TYVEK AND INSTALL NEW SIDING ON THE HOUSE.						
156						

Report Of Building/Improvement Permits Issued By The City Of Berwyn

Thursday, July 1, 2021

Between: 6/1/2021 And 6/30/2021

Name and Address	P.I.N. #	Census Class	Permit Issued	Permit #	Cost Of Improvements	Cost Of Permit
157 T. A. Stone 2635 S. Cuyler Avenue	16-29-301-017-0000	R	6/8/2021 Impr-L	90754-0	\$13,324.00	\$360.00
REBUILD NORTH ELEVATION PARAPET WALL, 2.5 FEET BELOW COPING, CHICAGO COMMON BRICK SECTION ONLY, REBUILD SOUTH ELEVATION PARAPET WALL SECTION, FROM SE CORNER TO CHIMNEY, 2.5 FEET BELOW COPING, SPOT POINT NORTH, SOUTH AND WEST ELEVATION AS NEEDED, REPLACE L						
158 J & H Valle 1936 S. Scoville Avenue	16-19-420-029-0000	R	6/8/2021 Fence-L	90755-0	\$0.00	\$135.00
REMOVING AND REPLACING FENCE FROM REAR OF HOUSE TO THE GARAGE 5FT SOLID + 1FT OPEN LATTICE, R/R GATE AT THE REAR OF HOUSE 5FT SOLID + 1FT LATTICE SOLID. INSTALLING SLIDING GATE AT THE ALLEY SIDE 6FT SOLID.						
159 Ricardo Acevedo & Lorena Var 2706 S. Cuyler Avenue	16-29-308-021-0000	R	6/8/2021 Impr-L	90756-0	\$10,000.00	\$285.00
REPLACING ROOF WITH SHINGLES, INSTALL ROOF DECKING, ROOF FLASHING AS NEEDED, UNDERLAYMENT, ICE AND WATER SHIELD, REPLACING SIDING WITH NEW VINYL SIDING.						
160 Paul McGraw 1248 S. Maple Avenue	16-19-100-038-0000	R	6/8/2021 Impr-L	90757-0	\$13,000.00	\$330.00
RE-ROOF ON THE HOUS EAND GARAGE, REPLACING ALUMNINUM SIDIN ON THE HOUSE ONLY, REPLACING WINDOW WRAPS/GUTTERS.						
161 David Reyes Salvador 6747 W. Riverside Drive	16-30-200-026-0000	R	6/8/2021 Impr-L	90758-0	\$300.00	\$40.00
INTERIOR DEMO - DEMO TO THE STUDS - NO STRUCTURAL DEMO.						
162 David M. Buckbee & Cassandr 3612 S. Wesley Avenue	16-31-401-045-0000	R	6/8/2021 Impr-L	90759-0	\$500.00	\$40.00
GRIND AND TUCKPOINT THE HOUSE WHERE NEEDED AND R/R AROUND 50 BRICKS.						
163 Andrew & Tressa Slater 1529 S. Grove Avenue	16-19-131-015-0000	R	6/8/2021 Fence-L	90760-0	\$2,346.00	\$135.00
REMOVE AND INSTALL A 5FT WOOD FENCE WITH 4FT GATE ALONG THE FRONT OF THE PROPERTY TO THE PRIVATE SIDEWALK, THEN DOWN THE PRIVATE SIDE WALK AND THEN ACROSS THE PRIVATE SIDEWALK TO THE LOT LINE - OK PER CDL						
164 Maria Ramos & Maximo Ramos 1522 S. Cuyler Avenue	16-20-123-029-0000	R	6/8/2021 Impr-L	90761-0	\$4,500.00	\$135.00
R/R 18 WINDOWS IN THE 1ST FLOOR LIVING ROOM, DINING ROOM, KITCHEN, PORCH AND 2 BEDROOMS - WINDOWS TO EGRESS CODE WHERE REQUIRED -- R/R 2 WINDOWS IN THE UNFINISHED ATTIC.						

Report Of Building/Improvement Permits Issued By The City Of Berwyn

Thursday, July 1, 2021

Between: 6/1/2021 And 6/30/2021

Name and Address	P.I.N. #	Census Class	Permit Issued	Permit #	Cost Of Improvements	Cost Of Permit
Vicente Escamilla 2640 S. East Avenue	16-30-403-034-0000	R	6/8/2021 Impr-L	90762-0	\$1,500.00	\$40.00
TUCKPOINT THE FRONT OF THE BUILDING IF GRINDING MUST TENT OR TARP AREA. WET GRINDING IS ALSO ALLOWED.						
165 3338-3344 Maple Ave LLC 3338-44 S. Maple Avenue	16-31-120-026-0000	R	6/8/2021 Impr-L	90763-0	\$37,000.00	\$1,165.00
REMODEL THE KITCHEN AND BATHROOM AND R/R WINDOWS TO EGRESS CODE IN UNITS 3344-1, 3344-2, 3344-3.						
166 Erika Kirchgatterer 6928 W. 34th Street	16-31-132-035-0000	R	6/9/2021 Gar-B	9765-0	\$39,111.00	\$325.00
DEMO EXISTING GARAGE AND BUILD NEW 24X24X12(H)						
167 Dr. Housing Painting Corp 1519 S. East Avenue	16-19-228-009-0000	R	6/9/2021 Impr-L	88579-1	\$0.00	\$100.00
PAYING FOR ADDITIONAL ELECTRICAL UNDERGROUND AND ELECTRICAL SERVICE INSPECTIONS						
168 LBS Management LLC 6243 W. 26th Street	16-29-126-032-0000	C	6/9/2021 Impr-L	89703-1	\$0.00	\$50.00
ROUGH PLUMBING REINSPECTION						
169 George Keating 6238 W. 26th street 405	16-29-302-038-1019		6/9/2021 HVAC-L	90764-0	\$4,286.00	\$140.00
R/R A/C UNIT. A/C CONDENSERS MUST BE LOCATED BEHIND THE HOUSE 3' FROM PROPERTY LOT LINE AND ELECTRICAL METER.						
170 Douglas R. & Walega & Caroly 2532 S. Wesley Avenue	16-30-225-026-0000	R	6/9/2021 Roof-L	90765-0	\$6,550.00	\$0.00
T/O AMD REROOF FLAT DORMER ROOF AND REROOF OVER EXISTING 1 LAYER OF SHINGLES ON GARAGE ROOF						
171 Francisco Gamez & Marha Mun 3604 S. Harvey Avenue	16-32-310-031-0000	R	6/9/2021 HVAC-L	90766-0	\$4,140.00	\$140.00
R/R A/C UNIT. MUST BE 3' FROM LOT LINE						
172 Luz Elena Gutierrez 1922 S. Lombard Avenue	16-20-324-028-0000	R	6/9/2021 Impr-L	90767-0	\$800.00	\$40.00
SPOT TUCKPOINT THE HOUSE. WATER HEATERS REQUIRE EXPANSION TANKS.						
173 Robert L. Matias, Jr. & Nancy E 6534 W. Cermak Road	16-19-428-026-0000	C	6/9/2021 Roof-L	90768-0	\$7,850.00	\$170.00
TEAR OFF AND REROOF THE BUILDING WITH MOD BIT.						
174 Tiburcio Mendez 1516 S. Home Avenue	16-19-127-022-0000	R	6/9/2021 Impr-L	90769-0	\$1,000.00	\$40.00
REMOVE AND REPLACE GARAGE SIDING.						
175 Juliana C. Contro 3412 S. Grove Avenue	16-31-134-032-0000	R	6/9/2021 Impr-L	90770-0	\$12,980.00	\$255.00
INSTALL NEW PAVER PATIO 165 SQ FEET SECTIONS IN FRONT OF THE GARAGE AND CONNECTING TO THE ESICTING SIDEWALK. ALL PAVERS MUST PITCH TO OWNE PROPERTY. JULIE #a1600372						
176						

Report Of Building/Improvement Permits Issued By The City Of Berwyn

Thursday, July 1, 2021

Between: 6/1/2021 And 6/30/2021

Name and Address	P.I.N. #	Census Class	Permit Issued	Permit #	Cost Of Improvements	Cost Of Permit
Edward & Sara Ionescu 2116 S. Wenonah Avenue	16-19-326-018-0000	R	6/9/2021 Impr-L	90771-0	\$18,248.85	\$545.00
INSTALL 159 FT OF INTERIOR DRAIN ILE, SUMP PUMP SYSTEM - 2 PUMPS DISCHARGE TO REAR OF BUILDING, 3FT OF 4" TRENCH DRAIN, 636 SQ FT OF WALL LINER. PERMA-DRY AIR SYSTEM AND SINGLE RECEPTACLE OUTLET ON DEDICATED CIRCUIT.						
177						
Steven Clairmont & cassandra 1631 S. Gunderson Avenue	16-19-406-004-0000	R	6/9/2021 Impr-L	90772-0	\$5,970.00	\$200.00
INSTALL A GALVANIZED EGRESS WINDOW WELL 49" X 36" 60"D W/COVER 40" X 40" IN SWING WINDOW -- WINDOW TO EGRESS CODE.						
178						
Eleanor Koval 6432 W. Pershing Road	16-31-424-026-0000	R	6/9/2021 Elec-L	90773-0	\$350.00	\$90.00
ADD 1 OUTLET IN 2 BEDROOM - WIRE MOLD AND INSTALL GFI IN GARAGE.						
179						
Samuel Vela Mota 2312 S. Lombard Avenue	16-29-111-025-0000	R	6/9/2021 Elec-L	90774-0	\$2,800.00	\$105.00
BRING ELECTRICAL IN THE GARAGE TO CODE, INSTALL A GFCI AND DEVICE AND LIGHT.						
180						
Lawrence Solnes 3619 S. Gunderson Avenue	16-31-413-008-0000	R	6/9/2021 Dump-L	90775-0	\$0.00	\$50.00
DUMPSTER ON THE STREET TO REMOVE UNWANTED DEBRIS. DUMPSTERS/PODS REQUIRE A FLASHING BARRICADE ON THE SIDE OF INCOMMING TRAFFIC.						
181						
Dominic Morrone 1811 S. Wisconsin Avenue	16-19-310-005-0000	R	6/9/2021 Plum-L	90776-0	\$14,500.00	\$50.00
SEWER REPAIR.						
182						
PMG Berwyn Investments 3200 S. Oak Park Avenue	16-31-107-043-0000		6/9/2021 Impr-L	90777-0	\$95,000.00	\$1,485.00
STRIP AMD REPLACE RUBBER MEMEBRANE AT PARKING LOT. RESTRIPE EXISTING PARKING SPACES (40) AND RESET 8 PARKING BLOCKS						
183						
Felix Zavala 2113 S. Elmwood Avenue	16-19-431-005-0000	R	6/9/2021 Fence-L	90778-0	\$1,500.00	\$135.00
R/R WOODEN FENCE AT ALLEY AND REPLACE WITH WROUGHT IRON/WOOD SLIDING FENCE WITH 6' HEIGHT. JULIE DIG # A1593178						
184						
FNMA 3725 S. Wenonah Avenue	16-31-319-009-0000	R	6/9/2021 Impr-L	90779-0	\$4,600.00	\$385.00
ATF FOR BATHROOM REMODEL, ANY OPEN LIGHT BULBS MUST BE MADE FULY ENCLOSED REPAIR GFCI ELECTRICAL OUTLETS LEFT OF KITCHEN SINK, ELECTRICAL CONUIT IN BASEMENT SOUTH WALL NOT PROPERLY STAPPED-B RING TO CODE, EXPOSED ELECTRIAL WIRES IN JUCTION BOX MUST BE BRO						

185

Report Of Building/Improvement Permits Issued By The City Of Berwyn

Thursday, July 1, 2021

Between: 6/1/2021 And 6/30/2021

Name and Address	P.I.N. #	Census Class	Permit Issued	Permit #	Cost Of Improvements	Cost Of Permit
186 Miguel Avalos 1427 S. Harvey Avenue	16-20-118-011-0000	R	6/9/2021 Roof-L	90780-0	\$1,500.00	\$50.00
187 Marie Corvatta 2738 S. Highland Avenue	16-29-309-036-0000	R	6/9/2021 Impr-L	90781-0	\$12,500.00	\$330.00
188 Sergio & Edy Muralles 1846 S. Kenilworth Avenue	16-19-313-037-0000	R	6/9/2021 Impr-L	90782-0	\$14,348.68	\$385.00
189 Rocio Figueroa 6930 W. Pershing Road	16-31-328-046-0000	R	6/9/2021 Impr-L	90783-0	\$5,000.00	\$135.00
190 German & Lumir Luna 1215 S. Harvey Avenue	16-20-103-013-0000	R	6/10/2021 Gar-B	9768-0	\$12,000.00	\$300.00
191 David T & Angela F Crawford N 3834 S. Wenonah Avenue	16-31-326-042-0000	R	6/10/2021 Bldg-B	9769-0	\$6,500.00	\$240.00
192 Nicolae F. Cazacu 1333 S. Clinton Avenue	16-19-113-014-0000	R	6/10/2021 Impr-L	90356-1	\$3,500.00	\$120.00
193 Jean M Gentile & Kevin Geiger 6510 W. 26th Place	16-30-405-012-0000	R	6/10/2021 Dump-L	90571-1	\$0.00	\$50.00
194 IH3 Property Illinois, LLC 2824-26 S. Harvey Avenue	16-29-318-030-0000	R	6/10/2021 Impr-L	90784-0	\$1,600.00	\$190.00

Report Of Building/Improvement Permits Issued By The City Of Berwyn

Thursday, July 1, 2021

Between: 6/1/2021 And 6/30/2021

Name and Address	P.I.N. #	Census Class	Permit Issued	Permit #	Cost Of Improvements	Cost Of Permit
<u>Philip & Debra Reilly</u> 3503 S. Elmwood Avenue	16-31-409-002-0000	R	6/10/2021 Impr-L	90785-0	\$5,500.00	\$150.00
<u>195</u> <u>Mary E. & Kevin T. O'Halloran</u> 6614 W. 34th Street	16-31-233-031-0000	R	6/10/2021 Impr-L	90786-0	\$9,850.00	\$210.00
<u>196</u> <u>Alicia & Rafael Navarro</u> 3710 S. Wenonah Avenue	16-31-318-014-0000	R	6/10/2021 HVAC-L	90787-0	\$12,430.00	\$140.00
<u>197</u> <u>Roy W. Kohnke, Sr. & Roy W.</u> 2737 S. Harvey Avenue	16-29-311-016-0000	R	6/10/2021 Impr-L	90788-0	\$2,450.00	\$105.00
<u>198</u> <u>Gerald E. Nealy</u> 2626 S. Euclid Avenue	16-30-400-027-0000	R	6/10/2021 Impr-L	90790-0	\$8,000.00	\$280.00
<u>199</u> <u>L O Realty Company</u> 6420 W. Cermak Road	99-99-999-000-0014	C	6/10/2021 Impr-L	90791-0	\$2,000.00	\$0.00
<u>200</u> <u>Victor Ostguin Abd Barbara Ost</u> 1527 S. Wesley Avenue	16-19-226-012-0000	R	6/10/2021 Roof-L	90792-0	\$2,500.00	\$40.00
<u>201</u> <u>William Andel Trust</u> 3749 S. Oak Park Avenue	16-31-415-019-0000	R	6/10/2021 Roof-L	90793-0	\$5,825.00	\$140.00
<u>202</u> <u>Lizabeth Lineras</u> 1851 S. Grove Avenue	16-19-315-021-0000	R	6/10/2021 Fence-L	90794-0	\$1,000.00	\$85.00
<u>203</u> <u>Isreal Hernandez</u> 1426 S. Oak Park Avenue	16-19-123-029-0000	R	6/10/2021 Roof-L	90795-0	\$4,000.00	\$175.00
<u>204</u>						

Report Of Building/Improvement Permits Issued By The City Of Berwyn

Thursday, July 1, 2021

Between: 6/1/2021 And 6/30/2021

Name and Address	P.I.N. #	Census Class	Permit Issued	Permit #	Cost Of Improvements	Cost Of Permit
Cesar F Deleon & Gridy Alexan 205 MA & M Goldbranson	2222 S. Gunderson Avenue 16-30-205-026-0000	R/R SOFFIT AND FASCIA ON THE HOUSE.	R	6/10/2021 Impr-L	90796-0	\$2,000.00 \$40.00
206 David Pasten-Rojano & 207 Jose Rodriguez, Maria Vasquez	3233 S. Wisconsin Avenue 16-31-110-009-0000	KITCHEN REMODEL, R/R CABINETS, COUNTER TOP AND SINK, BRING ELECTRIC AND PLUMBING TO CODE. INSTALL NEW DRYWALL ON THE CEILING AND WALLS. FLOOR TILE AND PAINTING. R/R RADIATOR.	R	6/10/2021 Impr-L	90797-0	\$15,600.00 \$650.00
208 James Stastny Trust	3747 S. Kenilworth Avenue 16-31-322-015-0000	R/R FRONT CONCRETE STEPS.	R	6/10/2021 Impr-L	90798-0	\$800.00 \$90.00
209 James & Deborah Ringstadt	1338 S. Clinton Avenue 16-19-112-041-0000	R/R MAIN ENTRANCE FLAT PORCH ROOF	R	6/10/2021 Roof-L	90799-0	\$200.00 \$50.00
210 Genevieve Castaneda & Javier	2233 S. Wesley Avenue 16-30-202-011-0000	TUCKPOINT SOUTH EAST CHIMNEY	R	6/10/2021 Impr-L	90800-0	\$850.00 \$40.00
211 Erika Nava	3239 S. Highland Avenue 16-32-120-034-0000	TUCKPOINTING REPAIRS ON CHIMNEY	R	6/10/2021 Impr-L	90801-0	\$450.00 \$40.00
212 Daniel Ramos	3833 S. Oak Park Avenue 16-31-420-012-0000	INSTALL A 25' X 13' PAVER PATIO PAVERS MUST PITCH TOWARDS OWN PROPERTY NOT NEIGHBOR'S OR CITY.	R	6/10/2021 Impr-L	90802-0	\$2,158.61 \$105.00
213 Luis D. Blanco and Wendy San	2111 S. Clarence Avenue 16-19-427-004-0000	T/O AND RESHINGLE HOUSE AND GARAGE ROOF. CALL FOR FINAL INSPECTION.	R	6/10/2021 Roof-L	90803-0	\$400.00 \$200.00
214 RMG Homes LLC	3225 S. Wesley Avenue 16-31-217-012-0000	INSTALL A 14' X 14FT PAVER PATIO IN FRONT OF THE GARAGE.	R	6/10/2021 Impr-L	90804-0	\$1,500.00 \$90.00
215 Eric Fredericks & Nora Frederic	1602 S. Highland Avenue 16-20-301-021-0000	REVENT THE BASEMENT BATHROOM, INSTALL A VENT TO EJECTOR PIT AND DECONVERT THE GREY BOX, LAUNDRY MACHINE AND DRYER (THERE WILL NOT BE A LAUNDRY ROOM AT THIS PROPERTY).PAYING FOR ATF PLUMBING INSPECTION FROM THE ORIGINAL PERMIT.	R	6/11/2021 Bldg-B	9532-1	\$400.00 \$190.00
216	3606 S. Wenonah Avenue 16-31-310-014-0000	SEWER REPAIR IN THE STREET.	R	6/11/2021 Bldg-B	9539-2	\$10,000.00 \$385.00
	7053 W. 26th Parkway 16-30-300-022-0000	DEMO AND REBUILD A 24'X20' X 12'(H) GARAGE.	R	6/11/2021 Gar-B	9770-0	\$24,500.00 \$325.00

Report Of Building/Improvement Permits Issued By The City Of Berwyn

Thursday, July 1, 2021

Between: 6/1/2021 And 6/30/2021

Name and Address	P.I.N. #	Census Class	Permit Issued	Permit #	Cost Of Improvements	Cost Of Permit
217 Esthela Olivera 3626 S. Euclid Avenue	16-31-400-041-0000	R	6/11/2021 Impr-L	90789-0	\$1,520.00	\$435.00
R/R 1 WINDOW IN THE UNFINISHED ATTIC AND 1ST FLOOR BATHROOM. ---- ATF WORK FROM 2009 - BOILERS TO FORCED AIR WITH FURNACE AND DUCT WORK -- NO A/C UNIT. REPAIR BACK GATE, INSTALL ELECTRIC IN BASEMENT, REPAIR DRYWALL, FIX AND REPLACE WATER PIPES, REPLACE CA						
218 Jeff Dahlgren 3012 S. Oak Park Avenue	16-30-324-032-0000	R	6/11/2021 Impr-L	90805-0	\$500.00	\$40.00
TUCKPOINT WALL FRONT OF THE HOUSE, BUFF COLOR.						
219 Michael D. Chester 2718 S. Harvey Avenue	16-29-310-028-0000	R	6/11/2021 Roof-L	90806-0	\$4,500.00	\$125.00
REMOVE AND REPLACE ENTIRE ROOFING SYSTEM ON HOUSE, REPLACE ANY BAD DECKING, INSTALL NEW VENTS, LEAD FLASHINGS, INSTALL ICE AND WATER SHIELD, ARCHITECTURAL SHINGLES, FELT.						
220 Elizabeth G Koshy 3428 S. East Avenue	16-31-233-022-0000	R	6/11/2021 Impr-L	90807-0	\$2,500.00	\$115.00
TEAR OFF FLAT ROOF SECTION ON THE GARAGE, FLASHING, PEEL AND STICK MATERIAL						
221 Armando Orozco 2647 S. Euclid Avenue	16-30-401-024-0000	R	6/11/2021 Impr-L	90808-0	\$4,850.00	\$125.00
REMOVE OLD ROOF DOWN TO DECK, R/R GUTTERS, INSTALL ICE AND WATER SHIELD, FELT PAPER, NEW ROOF SHINGLES (HOUSE AND GARAGE), NEW VENTS, AND ALUMINUM CAPPING						
222 Joel Chrastka 3416 S. Wenonah Avenue	16-31-130-020-0000	R	6/11/2021 Impr-L	90809-0	\$2,318.00	\$40.00
REMOVIGN AND REPLACING GARAGE VERHEAD DOOR, REPLACIN EXISTING DOOR OPENER. -SAME SIZE						
223 Elmwood Place Condos 6430-36 W. 18th Street	99-99-999-000-0138	C	6/11/2021 Roof-L	90810-0	\$32,995.00	\$545.00
TEAR OFF AND REROOF THE BUILDING WITH MOD BIT.						
224 Jose Figueroa 1224 S. Wesley Avenue	16-19-201-031-0000	R	6/11/2021 Fence-L	90811-0	\$3,300.00	\$135.00
INSTALLING GATE AT THE FRONT OF PROEPRTY 5FT+1FT OPEN LATTICE FROM HOUSE TO HOUSE AND AT THE REAR OF PROPERTY 6FT SOLID FROM GARAGE TO GARAGE BOTH ON THE SOUTH SIDE (HAS NEIGHBOR PERMISSION) INSTALLING FENCE FROM REAR OF HOUSE TO END OF GARAGE ON THE NORT						

Report Of Building/Improvement Permits Issued By The City Of Berwyn

Thursday, July 1, 2021

Between: 6/1/2021 And 6/30/2021

Name and Address	P.I.N. #	Census Class	Permit Issued	Permit #	Cost Of Improvements	Cost Of Permit
Alfredo Reyes 1313 S. East Avenue	16-19-212-006-0000	R/R THE SIDEWALK ON THE SOUTHSIDE AND BEHIND OF THE HOUSE. ELECTRICAL METER SOCKET UPGRADE. CONCRETE MUST PITCH TOWARDS OWN PROPERTY NOT NEIGHBOR'S OR CITY.	R	6/11/2021 Impr-L	90812-0	\$2,000.00 \$190.00
225 Robert Dziedzic	2707 S. Ridgeland Avenue	16-29-308-004-0000	INSTALL A FIRE ALARM SYSTEM TO CODE.	C/R	6/11/2021 Impr-L	90813-0 \$3,500.00 \$270.00
226 Steve J & Sandy Ostrowski	6500 W. 33rd Street	16-31-225-039-0000	ANY OPEN BULB LIGHT FIXTURES MUST BE CONVERTED TO FULLY ENCLOSED BULB FIXTURES IN THE BASEMENT, ATF FOR MAIN LEVEL BATHROOM REMODEL, BEDROOM WINDOWS MUST BE UP TO EGRESS CODE, BASEMENT BATHROOM REQUIRES A PERMANENT CONTROLLABLE HEAT SOURCE INSTALLED TO CO	R	6/11/2021 Impr-L	90814-0 \$700.00 \$140.00
227 Rapport Builders LLC	1828 S. Highland Avenue	16-20-309-025-0000	INTERIOR REMODEL. 1ST FLOOR TO CONSIST OF- KITCHEN, DINING ROOM, LIVING ROOM, FULL BATH EXISTING, 1 EXISTING BEDROOM. 2ND FLOOR/ATTIC TO CONSIST OF- RECREATIONAL ROOM, FULL BATH EXISTING, 3 EXISTING BEDROOMS. FINISHED BASEMENT TO CONSIST OF- FULL BATH EXI	R	6/14/2021 Bldg-B	9772-0 \$104,500.00 \$4,110.00
228 Rodriquez	3629 S. Wesley Avenue	99-99-999-000-0092	PLUMBING FINAL REINSPECTION ON WATER HEATER	R	6/14/2021 Plum-L	72867-1 \$0.00 \$50.00
229 M. Bielskus	2535 S. Clinton Avenue	16-30-115-014-0000	INSTALL NEW OUTLETS IN KITCHEN, REPLACE OLD ELECTRICAL PANEL AND UPGRADE TO A 200 AMP SERVICE AND INSTALL GROUNDING RO WATER METER.	R	6/14/2021 Elec-L	90276-1 \$55.00 \$55.00
230 Ahmad Rumaneh & Ihab Oweis	6332 W. 26th Street	16-29-300-008-0000	DUMPSTER ON STREET. DUMPSTERS/PODS REQUIRE A FLASHING BARRICADE ON THE SIDE OF INCOMMING TRAFFIC.	C/R	6/14/2021 Dump-L	90815-0 \$0.00 \$50.00
231 Chierici Property #1 LLC	3040 S. Clarence Avenue	16-30-417-041-0000	GRINDING AND TUCKPOINTING PARAPET WALL, GRINDING AND TUCKPOINTING ALL LIMESTONE, INSTALLING 2 LIMESTONE ON RIGHT SIDE WINDOW, WATERPROOF SEALING PARAPET.	R	6/14/2021 Impr-L	90816-0 \$1,425.00 \$40.00
232						

Report Of Building/Improvement Permits Issued By The City Of Berwyn

Thursday, July 1, 2021

Between: 6/1/2021 And 6/30/2021

Name and Address	P.I.N. #	Census Class	Permit Issued	Permit #	Cost Of Improvements	Cost Of Permit		
Tao Duan & Yan Wang 233 Mabel Eliza Fleming & Theresa	2821 S. Harlem Avenue ste 6 3020 S. Clarence Avenue	99-99-999-000-0737	INSTALL NON-ILLUMINATED SIGN AT PROPERTY (12x16).	R	6/14/2021 Sign-L	90817-0	\$0.00	\$0.00
234 Raymundo Ginez & Natalia Gin	3322 S. Wesley Avenue	16-31-222-025-0000	2 A/C REPLACEMENT 13 SEER 2 TON- 3FT FROM PROPERTY LINE	R	6/14/2021 HVAC-L	90818-0	\$8,745.00	\$140.00
235 Rafael & Silvia Perez	3322 S. Wesley Avenue	16-31-222-025-0000	INSTALL PAVER PATIO ON EAST SIDE OF GARAGE (20x11).	R	6/14/2021 Impr-L	90819-0	\$4,500.00	\$135.00
236 Flor Mejia	1514 S. Lombard Avenue	16-20-126-027-0000	A/C REPL 13 SEER 2 1/2 TON- 3DT FROM PROPERTY LINE	R	6/14/2021 HVAC-L	90820-0	\$5,417.00	\$140.00
237 Sara Tichy	1333 S. Maple Avenue	16-19-109-014-0000	AC REPL 13 SEER 2 1/2 TON-3FT FROM PROPERTY LINE	R	6/14/2021 HVAC-L	90821-0	\$8,000.00	\$140.00
238 Roger Seilheimer	1429 S. Wesley Avenue	16-19-218-013-0000	A/C REPL 13 SEER 3 TON- 3FT FROM PROPERTY LINE	R	6/14/2021 HVAC-L	90822-0	\$7,425.00	\$140.00
239 Angel & Gloria Favila	2835 S. Cuyler Avenue	16-29-317-015-0000	DUMPSTER TO BE PUT ON THE STREET . (FURNITURE REMOVAL). DUMPSTERS/PODS REQUIRE A FLASHING BARRICADE ON THE SIDE OF INCOMMING TRAFFIC.	R	6/14/2021 Dump-L	90823-0	\$0.00	\$50.00
240 Esthela Olivera	2811 S. Cuyler Avenue	16-29-317-043-0000	R/R GARAGE CONCRETE FLOOR & APRON. R/R EXISTING CONCRETE PAD (24x9). CONCRETE MUST PITCH TOWARDS OWN PROPERTY NOT NEIGHBOR'S OR CITY.	R	6/14/2021 Impr-L	90824-0	\$7,252.00	\$180.00
241 Harold Landt	3626 S. Euclid Avenue	16-31-400-041-0000	R/R 9 TTOAL WINDOWS 1ST FLOOR LIVING ROOM	R	6/14/2021 Impr-L	90825-0	\$7,779.00	\$130.00
242 Howard Kahn	1244 S. Maple Avenue	16-19-100-037-0000	R/R 12 WINDOWS TOTAL. LIVING ROOM (6), DINING ROOM (3), AND BEDROOM (3). BRING WINDOWS TO EGRESS CODE WHERE NEEDED.	R	6/14/2021 Impr-L	90826-0	\$8,300.00	\$195.00
243 Mathew & Sonya Raymond	3206 S. Kenilworth Avenue 1B	16-31-113-006-7003	R/R WATER HEATER TO CODE.		6/14/2021 Impr-L	90827-0	\$1,549.38	\$85.00
244	2627 S. Clarence Avenue	16-30-403-016-0000	TEAR OFF ANAD REROOF, GUTTERS, REMOVE PERGOLA. DOWNSPOUTS MUST DRAIN TO PRIVATE PROPERTY	R	6/14/2021 Impr-L	90828-0	\$9,500.00	\$285.00

Report Of Building/Improvement Permits Issued By The City Of Berwyn

Thursday, July 1, 2021

Between: 6/1/2021 And 6/30/2021

Name and Address	P.I.N. #	Census Class	Permit Issued	Permit #	Cost Of Improvements	Cost Of Permit		
Charles & Rosalba Burke 245	1801 S. Ridgeland Avenue	16-20-308-036-0000	R/R 1 KITCHEN WINDOW.	R	6/14/2021 Impr-L	90829-0	\$1,312.00	\$40.00
Emily Barrios 246	3425 S. Highland Avenue	16-32-132-055-0000	REMOVING AND REPLACING EXISTING WALKWAY FROM FRONT OF PROPERTY TO THE ALLEY, R/R CONCRETE STAIRS AND FRONT APPROACH. INSTALLING NEW CONCRETE PATIO 28X16.	R	6/14/2021 Impr-L	90830-0	\$8,500.00	\$195.00
Roberto & Margarita Ramirez 247	2116 S. Grove Avenue	16-19-330-017-0000	R/R A SECTION OF THE SIDEWALK ON THE SOUTH SIDE OF THE HOUSE.	R	6/14/2021 Impr-L	90831-0	\$1,200.00	\$90.00
Marceida M. Lopez 248	2430 S. Lombard Avenue	16-29-119-033-0000	INSTALL ADDITIONAL OUTLETS IN BASEMENT, OUTDORR PORCH, DINING ROOM & KITCHEN. REPLACE & INSTALL NEW LIGIHTS IN KITCHEN, GARAGE, BASEMENT, OUTDOOR. REPLACE EXISTING 100A PANEL 20 SPACE W/100A 30 SPACE PANEL. UPGRADE ELECTRICAL PANEL TO 30 CIRCUITS.	R	6/14/2021 Elec-L	90832-0	\$4,248.00	\$135.00
RUBEN SANCHEZ 249	1827 S. Cuyler Avenue	16-20-309-010-0000	R/R ASPHALT DRIVEWAY. R/R SECTION OF ASPHALT DRIVEWAY AT FRONT OF PROPERTY (PAD) W/ PAVERE SAME SIZE AS EXISTING.	R	6/14/2021 Impr-L	90833-0	\$1,000.00	\$90.00
Francisco & Maricela Meraz 250	2706 S. Grove Avenue	16-30-313-016-0000	R/R 5 FIRST FLOOR LIVING ROOM WINDOWS.	R	6/14/2021 Impr-L	90834-0	\$4,900.65	\$85.00
Mark Mrsnik 251	3239 S. Ridgeland Avenue	16-32-111-019-0000	R/R FENCE AT THE FRONT OF PROPERTY ON THE SOUTH SIDE 5FT+1FT OPEN LATTICE. INSTALLING NEW FENCE AT THE REAR OF PROPERTY ON THE SOUTH SIDE WITH OWN POST 6FT SOLID. INSTALLING GATE AT THE ALLEY SIDE ON THE NORTH SIDE OF THE PROPERTY 6FT SOLID USING OWN POST	R	6/14/2021 Fence-L	90835-0	\$0.00	\$135.00
Bradly Barth 252	1821 S. Clinton Avenue	16-19-313-009-0000	REMOVING AND REPLACING FENCE ON THE NORTH SIDE OF THE PROPERTY FROM THE REAR OF HOUSE TO THE END OF GARAGE 5FT. INSTALLING 2 GATES AT THE REAR OF HOUSE AND AT THE ALLEY ON THE SOUTH SIDE OF THE PROPERTY 5FT USING OWN POST. HAS NEIGHBOR PERMISSION	R	6/14/2021 Fence-L	90836-0	\$0.00	\$135.00

Report Of Building/Improvement Permits Issued By The City Of Berwyn

Thursday, July 1, 2021

Between: 6/1/2021 And 6/30/2021

Name and Address	P.I.N. #	Census Class	Permit Issued	Permit #	Cost Of Improvements	Cost Of Permit
253 Robert F. & Betty Ramirez 1922 S. Highland Avenue	16-20-322-025-0000	R	6/14/2021 Roof-L	90837-0	\$15,180.00	\$325.00
254 Fabiola Suarez 1221 S. Euclid Avenue	16-19-201-013-0000	R	6/14/2021 Impr-L	90838-0	\$1,430.00	\$90.00
255 Pedro Tamayo & Dayenis Urqui 1818 S. East Avenue	16-19-411-027-0000	R	6/15/2021 Bldg-B	9703-2	\$0.00	\$0.00
256 Francisco Allen 1423 S. Cuyler Avenue	16-20-116-010-0000	R	6/15/2021 Gar-B	9773-0	\$0.00	\$25.00
257 CASTALDO DEVELOPMENT, 3841 S. Cuyler Avenue	16-32-325-031-0000	R	6/15/2021 Impr-L	89857-1	\$0.00	\$50.00
258 Omar Pimental 3124 S. Clinton Avenue	16-31-104-023-0000	R	6/15/2021 Fence-L	90839-0	\$10,000.00	\$135.00
259 Rodriquez 3629 S. Wesley Avenue	99-99-999-000-0092	R	6/15/2021 Fence-L	90840-0	\$4,600.00	\$135.00

Report Of Building/Improvement Permits Issued By The City Of Berwyn

Thursday, July 1, 2021

Between: 6/1/2021 And 6/30/2021

Name and Address	P.I.N. #	Census Class	Permit Issued	Permit #	Cost Of Improvements	Cost Of Permit
VICTORINO ARGUETA PERE 1826 S. Wenonah Avenue 260	16-19-310-033-0000	R	6/15/2021 Impr-L	90841-0	\$4,350.00	\$185.00
Michael Angarone & Donna Pat 2110 S. Clinton Avenue 261	16-19-328-015-0000	R	6/15/2021 Elec-L	90842-0	\$545.00	\$90.00
Ronald & Laura Pacione 2424 S. Highland Avenue 262	16-29-117-027-0000	R	6/15/2021 HVAC-L	90843-0	\$5,300.00	\$140.00
Cellia Castillo 3715 S. Oak Park Avenue 263	16-31-415-007-0000	R	6/15/2021 Impr-L	90844-0	\$600.00	\$190.00
Norma Angeles 2712 S. Lombard Avenue 264	16-29-311-024-0000	R	6/15/2021 Impr-L	90845-0	\$4,500.00	\$135.00
Juan Aguirre & Sandra Garcia 1920 S. Wesley Avenue 265	16-19-417-023-0000	R	6/15/2021 Plum-L	90846-0	\$9,190.00	\$250.00
Sonia Martinez 3728 S. Elmwood Avenue 266	16-31-419-096-0000	R	6/15/2021 Roof-L	90847-0	\$8,822.00	\$220.00
Dolores Gordon 6506 Pershing Road 267	16-31-423-056-0000	R	6/15/2021 Impr-L	90848-0	\$5,839.24	\$225.00
Anthony Parqueth 3207 S. Ridgeland Avenue 268	16-32-111-049-0000	R	6/15/2021 Roof-L	90849-0	\$7,265.00	\$170.00

Report Of Building/Improvement Permits Issued By The City Of Berwyn

Thursday, July 1, 2021

Between: 6/1/2021 And 6/30/2021

Name and Address	P.I.N. #		Census Class	Permit Issued	Permit #	Cost Of Improvements	Cost Of Permit
<u>269</u> Ricardo & Ariana Macedo 1833 S. Cuyler Avenue	16-20-309-012-0000	TUCKPOINTING FRONT OF THE HOUSE	R	6/15/2021 Impr-L	90850-0	\$3,000.00	\$0.00
<u>270</u> Lucile F Evans 3131 S. Wisconsin Avenue	16-31-102-032-0000	INSTALL A 50 GALLON HOT WATER TANK W/ EXPANSION TANK. REMOVE SOFTENER OLD PIPES & REDO PIPES W/ NEW BALL VALVE & REPLACING TOLIET.	R	6/15/2021 Impr-L	90851-0	\$5,515.45	\$85.00
<u>271</u> STKH Enterprises, LLC 2241 S. Gunderson Avenue	16-30-206-021-0000	REMOVING AND REPLACING SIDEWALK ON THE SOUTH SIDE OF PROPERTY FROM FRONT OF PROPERTY TO THE GARAGE. ABOUT 493 SQ FT OF CONCRETE	R	6/15/2021 Impr-L	90852-0	\$4,900.00	\$135.00
<u>272</u> John & Jose Mendoza 1630 S. Ridgeland Avenue	16-19-407-021-0000	R/R CONCRETE PATIO IN THE BACKYARD, ADDING ABOUT 1FT OF CONCRETE TO EXISTING PATIO, R/R CONCRETE WALKWAY TO GARAGE, R/R CONCRETE GARDEN WALKWAY IN FRONT OF HOUSE, INSTALLING ABOUT 1FT OF RIVER ROCK NEXT TO HOUSE ON THE SOUTH SIDE. JULIE IDG# ATTACHED.	R	6/15/2021 Impr-L	90853-0	\$2,500.00	\$105.00
<u>273</u> Roberto Heredia & Michael Ken 6540 W. 26th Street	16-30-404-004-0000	REPLACING AIR CONDITIONER W/ 3 TON CONDENSOR AND COIL WITH NEW LINESET TO EXISTING LOCATION AND EXISTING FURNACE AND ELECTRIC	R	6/15/2021 HVAC-L	90854-0	\$4,500.00	\$140.00
<u>274</u> Anthony S. & Nick A. Cerabona 1634 S. Wenonah Avenue	16-19-302-032-0000	REPLACE AIR CONDITIONING UNIT WITH 2.5 TON CONDENSOR AND 2.5 TON AIR HANDLER TO EXISTING LINESET AND ELECTRIC	R	6/15/2021 HVAC-L	90855-0	\$7,350.00	\$140.00
<u>275</u> Jose Luis Patino 1333 S. East Avenue	16-19-212-047-0000	INSTALLING NEW ASPHALT PATIO/SLAB NEXT TO GARAGE ON THE SOUTH SIDE OF PROPERTY 38X4.5	R	6/15/2021 Impr-L	90856-0	\$250.00	\$90.00
<u>276</u> D. Tomasewski 3017 S. Oak Park Avenue	16-30-415-008-0000	R/R FRONT PORCH DECKS BOARDS, RISERS, TREADS AND HANDRAILS TO CODE.	R	6/15/2021 Impr-L	90857-0	\$2,500.00	\$55.00
<u>277</u> Joseph Zajac 6851 W. 30th Place	16-30-324-016-0000	REMOVE GUTTER AND DOWNSPOUT, REPLACE FASCIA BOARD, CAP THE FASCIA BOARD WITH WHITE ALUM, REINSTALL THE PREVIOUSLY SAVED GUTTER. RESEAL WITH CAP SEALER,	R	6/15/2021 Impr-L	90858-0	\$960.00	\$0.00

Report Of Building/Improvement Permits Issued By The City Of Berwyn

Thursday, July 1, 2021

Between: 6/1/2021 And 6/30/2021

Name and Address	P.I.N. #	Census Class	Permit Issued	Permit #	Cost Of Improvements	Cost Of Permit
277 Terry and Louise Mcmanmon 1636 S. Oak Park Avenue	16-19-307-034-0000	R	6/15/2021 Elec-L	90859-0	\$2,675.00	\$105.00
ADD AN ADDITIONAL METER- CHANGE METER RACK FROM 3 METERS TO 4 METERS. INSTALL EMERGENCY LIGHTING IN THE FRONT AND REAR HALLWAYS, SMOKE DETECTIONS ARE REQUIRED IN ALL BEDROOMS AND AT ALL 3 LEVELS IN THE FRONT AND REAR HALLWAYS, SMOKE/CO2 DETECTORS ARE REQ						
278 Oscar & Victoria Quiroz 1402 S. Scoville Avenue	16-19-220-021-0000	R	6/15/2021 Impr-L	90860-0	\$2,000.00	\$90.00
TUCKPOINTING ON THE HOUSE AND GARAGE AS NEEDED. ADDING A NEW LAYER OF SIDING ON THE PORCH.						
279 Nenci & Socorro Rodriguez 1342 S. Lombard Avenue	16-20-110-033-0000	R	6/15/2021 Impr-L	90861-0	\$2,500.00	\$105.00
INSTALL A 4FT WIDE SIDEWALK IN FRONT OF THE GARAGE & A 15FT ROUND CIRCLE PATIO IN FRONT OF THE GARAGE. CONCRETE MUST PITCH TOWARDS OWN PROPERTY NOT NEIGHBOR'S OR CITY.						
280 Carlos Rios 2842 S. Harvey Avenue	16-29-318-039-0000	R	6/15/2021 Fence-L	90862-0	\$6,600.00	\$135.00
INSTALLING FENCE ON THE NORTH SIDE OF PROPERTY FROM BACK OF HOUSE THE ALLEY 5FT+1FT OPEN LATTICE. INSTALLING 6FT SOLID GATE AT THE ALLEY CONNECTING TO GARAGE. INSTALLING GATE ON THE SOUTH SIDE PF PROPERTY AT THE BACK OF HOUSE USING OWN POST 5FT+1FT OPEN L						
281 Edward & Ana M. Espinoza 2948 S. Wisconsin Avenue	16-30-315-032-0000	R	6/15/2021 Impr-L	90863-0	\$3,400.00	\$100.00
INSTALL IRRIGATION SYSTEM SURROUNDING HOUSE INCLUDING PARKWAY						
282 Patricia Flory 3034 S. Euclid Avenue	16-30-415-041-0000	R	6/15/2021 Impr-L	90864-0	\$2,000.00	\$40.00
REMOVIGN AND REPLACING 6 TOTAL WINDOWS IN THE 1ST FLOOR LIVING ROOM (3) AND 2ND FLOOR LIVING ROOM (3)						
283 SMC Sisters Convent 1431 S. Euclid Avenue	16-19-217-001-0000	C	6/16/2021 Impr-L	89909-1	\$0.00	\$100.00
PAYING FOR AS BUILT INVOICE FROM FSC-----RETROFIT EXISTING BUILDING W/ NEW FIRE SPRINKLER SYSTEM IN ACCORDANCE W/ NFPA & LOCAL FIRE CODES.						
284 Nicole Petrey 1847 S. Gunderson Avenue	16-19-414-019-0000	R	6/16/2021 Impr-L	90865-0	\$4,250.00	\$145.00
TUCKPOINT NORTH, SOUTH, & EAST SIDE PARAPET WALLS. IF GRINDING MUST TENT OR TARP AREA. WET GRINDING IS ALSO ALLOWED.						
285						

Report Of Building/Improvement Permits Issued By The City Of Berwyn

Thursday, July 1, 2021

Between: 6/1/2021 And 6/30/2021

Name and Address	P.I.N. #	Census Class	Permit Issued	Permit #	Cost Of Improvements	Cost Of Permit
Gregorio Hernandez-Ortega 1331 S. Elmwood Avenue 286	16-19-215-014-0000	R	6/16/2021 HVAC-L	90866-0	\$4,325.00	\$140.00
R/R A/C UNIT. A/C CONDENSERS MUST BE LOCATED BEHIND THE HOUSE 3' FROM PROPERTY LOT LINE AND ELECTRICAL METER.						
Daniel Head 2519 S. Elmwood Avenue 287	16-30-231-008-0000	R	6/16/2021 HVAC-L	90867-0	\$5,225.00	\$140.00
R/R A/C UNIT. A/C CONDENSERS MUST BE LOCATED BEHIND THE HOUSE 3' FROM PROPERTY LOT LINE AND ELECTRICAL METER.						
Jose & Veronica Alonzo 3623 S. East Avenue 288	16-31-411-006-0000	R	6/16/2021 HVAC-L	90868-0	\$9,185.00	\$190.00
R/R FURNACE AND A/C UNIT -- RE0USE EXISTING LINER. A/C CONDENSERS MUST BE LOCATED BEHIND THE HOUSE 3' FROM PROPERTY LOT LINE AND ELECTRICAL METER.						
Juan C. & Mayra A. Espinosa 2121 S. Kenilworth Avenue 289	16-19-330-008-0000	R	6/16/2021 Impr-L	90869-0	\$7,900.00	\$235.00
JOB STOP/ATF: R/R GUTTERS ON HOUSE. R/R SIDING ON HOUSE. DOWNSPOUTS MUST DISBURSE ONTO PRIVATE PROPERTY.						
L & N Beringer 3620 S. Ridgeland Avenue 290	16-31-414-028-0000	R	6/16/2021 Fence-L	90870-0	\$1,990.00	\$135.00
INSTALL 5FT CHAIN LINK GATE (CANNOT SWING MORE THAN 2FT INTO THE ALLEY) ALONG THE ALLEY AND A 6FT WOOD FENCE NEXT TO THE GARAGE ALONG THE ALLEY.						
Maria Araiza 2447 S. Clinton Avenue 291	16-30-110-016-0000	R	6/16/2021 Fence-L	90871-0	\$4,600.00	\$100.00
REMOVE THE SOUTHSIDE FENCE FROM THE END OF THE HOUSE TO THE FRONT OF THE GARAGE AND INSTALL A 6FT WOOD FENCE.						
Eduardo Prieto 6448 W. 28th Place 292	16-30-414-038-0000		6/16/2021 HVAC-L	90872-0	\$3,500.00	\$140.00
INSTALLATION OF 2 1/2 TON A/C WITH COIL, LINESETS, PAD, WHIPS, DISCONNECTS, SHEET METAL, DRAINS, THERMOSTAT AND SEAL OF DUCT.						
Maria Rodarte, Jorge Carrillo T 2341 S. Ridgeland Avenue 293	16-29-108-017-0000	R	6/16/2021 Impr-L	90873-0	\$900.00	\$40.00
R/R LIVING ROOM WINDOW.						
Eusebio Molina Jr 3720 S. Gunderson Avenue 294	16-31-418-029-0000	R	6/16/2021 Impr-L	90874-0	\$3,000.00	\$0.00
INSTALLING A 35' X 17' PATIO IN THE REAR YARD. CONCRETE MUST PITCH TOWARDS OWN PROPERTY NOT NEIGHBOR'S OR CITY.						
Gregory C. Delgado 1640 S. Wenonah Avenue 295	16-19-302-035-0000	R	6/16/2021 Impr-L	90875-0	\$1,500.00	\$90.00
REMOVING AND REPLACING EXISTING WALKWAY FROM THE BACK OF THE HOUSE INCLUDING SERVICE WALKWAY TO THE GARAGE. NO SIZE CHANGE.						

Report Of Building/Improvement Permits Issued By The City Of Berwyn

Thursday, July 1, 2021

Between: 6/1/2021 And 6/30/2021

Name and Address	P.I.N. #	Census Class	Permit Issued	Permit #	Cost Of Improvements	Cost Of Permit
296 Trina Whiteside 2710 S. Highland Avenue	16-29-309-024-0000	R	6/16/2021 Impr-L	90876-0	\$10,168.00	\$425.00
INTERIOIR DRAIN TILE, SUMP PUMP, UNDERGROUND EXTENSION, RUN NEW ELECTRIC FOR SYSTEM. DISCHARGE TO REAR OF PROPERTY. JULIE DIG # ATTACHED A1593773						
297 Alex & Amelia Campos 1630 S. Grove Avenue	16-19-306-025-0000	R	6/16/2021 Impr-L	90877-0	\$3,011.00	\$90.00
REMOVIGN AND RPELACING 3 WINDOWS IN THE PARTIALLY FINISHED BASEMENT. BRING WINDOWS TO EGRESS CODE WHERE NEEDED.						
298 Miguel A. & Nancy Palacios 1331 S. Euclid Avenue	16-19-209-014-0000	R	6/16/2021 Fence-L	90878-0	\$0.00	\$135.00
REMOVING AND REPLACING FENCE ON THE NORTH SIDE OF PROPERTY FROM BACK OF HOUSE TO THE GARAGE 4FT HEIGHT. REMOVING AND REPLACING FENCE ON THE SOUTH SIDE OF PROPERTY WITH NEIGHBOR PERMISSION FROM BACK OF HOUSE THE THE GARAGE 5FT+1FT OPEN LATTICE. JULIE DIG A						
299 Abraham Pulido 1608 S. Scoville Avenue	16-19-404-023-0000	R	6/16/2021 Fence-L	90879-0	\$7,000.00	\$135.00
INSTALL NEW 5FT + 1FT OPEN LATTICE FENCE ON SOUTH SIDE OF PROPERTY TO CODE (NO FENCE EXISTS CURRENTLY). INSTALL NEW 6FT SOLID FENCE AT ALLEY TO CODE.						
300 Blanca & Pedro Gaitan 1516 S. Oak Park Avenue	16-19-131-030-0000	R	6/16/2021 Roof-L	90880-0	\$1,600.00	\$40.00
REMOVING AND REPLACING GARAGE ROOF WITH SHINGLES						
301 Mr. Zitnik 1404 S. Gunderson Avenue	16-19-221-022-0000	R	6/17/2021 Gar-B	9774-0	\$21,500.00	\$325.00
DEMO & REBUILD GARAGE 18 x 20 x 12 (H). JULIE DIG #A1680916						
302 Berwyn Gateway Partners II, L 7124 W. Cermak Road	16-19-324-034-0000	C	6/17/2021 Impr-L	90881-0	\$110,000.00	\$3,160.00
INTERIOR REMODELING TO STARBUCKS. NEW BEVERAGE CASEWORK, RELOCATING SOME BAR EQUIPMENT/SINKS, NEW FINISHES AND FIXTURES IN THE BAR AND CAFÉ AREA.						
303 L O'Connell 3111 S. Clarence Avenue	16-31-203-005-0000	R	6/17/2021 Roof-L	90882-0	\$9,100.00	\$185.00
ROOF REPLACEMENT ON THE HOUSE ONLY WITH SHINGLES, WATER SHIELD MEMBRANE, FELT, CHIMNEY FLASHING						
304 Alberto Moreno & Sandra Ibarra 3201 S. Scoville Avenue	16-31-213-010-0000	R	6/17/2021 Impr-L	90883-0	\$3,500.00	\$40.00
R/R 650 FT OF HARDWOOD FLOORING AT PROPERTY.						

Report Of Building/Improvement Permits Issued By The City Of Berwyn

Thursday, July 1, 2021

Between: 6/1/2021 And 6/30/2021

Name and Address	P.I.N. #		Census Class	Permit Issued	Permit #	Cost Of Improvements	Cost Of Permit
305 Patrick Mooney & Samntha Mic 2902 S. Wisconsin Avenue	16-30-315-016-0000	R/R GARAGE OVERHEAD DOOR. SAME SIZE.	R	6/17/2021 Impr-L	90884-0	\$2,967.54	\$55.00
306 Justina Haka & Neal Christyso 6927 W. 31st Street	16-30-325-026-0000	REMOVE AND REPLACE EXISTING CABINETS, NO WALLS WILL BE MOVED OR TAKEN DOWN., SMALL PIECES OF DRYWALL, NO KITCHEN HOOD.	R	6/17/2021 Impr-L	90885-0	\$9,000.00	\$395.00
307 V. Sanchez & G. Sandoval 3140 S. Kenilworth Avenue	16-31-105-022-0000	REMOVING AND REPLACING EXISTING CONCRETE PATIO WITH NEW STAMPED CONCRETE AND EXTENDING PATIO APPROX 2' MORE. REMOVING AND REPLACING WALKWAY FROM GARAGE TO REAR OF PROPERTY. JULIE DIG# ATTACHED.	R	6/17/2021 Impr-L	90886-0	\$4,300.00	\$135.00
308 Joseph Huizar 2730 S. Harvey Avenue	16-29-310-033-0000	REMOVE CONCRETE WALKWAY FROM END OF HOUSE TO START OF GARAGE AND MOVE 6 INCHES OVER TO CREATE NEW CONCRETE WALK. ORIGINAL SIDEWALK LOCATION WILL BE GRASS AREA. CONCRETE MUST PITCH TOWARDS OWN PROPERTY NOT NEIGHBOR'S OR CITY.	R	6/17/2021 Impr-L	90887-0	\$2,000.00	\$90.00
309 Thomas & Maureen Ferrara 6923 W. 26th Street	16-30-115-030-0000	R/R GUTTERS ON THE HOUSE. DOWNSPOUTS MUST DISBURSE ONTO PRIVATE PROPERTY.	R	6/17/2021 Impr-L	90888-0	\$1,848.00	\$340.00
310 Daniel Woolridge 2325 S. Elmwood Avenue	16-30-215-008-0000	ATF- INSTALLATION OF ELECTRICAL PERMANENT CONTROLLABLE HEAT SOURCE WITH THERMOSTAT IN ATTIC. ELECTRIC WALL HEATER ALLOWED, MUST BE CORRECT SIZE FOR ROOM, HAVE THERMOSTAT AND WIRED CORRECTLY.	R	6/17/2021 Impr-L	90889-0	\$500.00	\$140.00
311 Marisol Alvelo & Saul Gonzalez 3644 S. Harvey Avenue	16-32-310-026-0000	INSTALL PAVERS ON SOUTH SIDE OF GARAGE 20 x 9.8. R/R ALLEY GATE/FENCE WITH MOTOR OPERATED SLIDING GATE.	R	6/17/2021 Impr-L	90890-0	\$0.00	\$0.00
312 Nancy Notari & Diane Lallone 2246 S. Scoville Avenue	16-30-204-038-0000	TEAR OFF AND RE-ROOF WITH SHINGLES, ICE AND WATER SHIELD, AND SYNTHETIC FELT. HOUSE AND GARAGE.	R	6/17/2021 Roof-L	90891-0	\$5,500.00	\$140.00

Report Of Building/Improvement Permits Issued By The City Of Berwyn

Thursday, July 1, 2021

Between: 6/1/2021 And 6/30/2021

Name and Address	P.I.N. #	Census Class	Permit Issued	Permit #	Cost Of Improvements	Cost Of Permit
Arnulfo Cerrillo 3737 S. Euclid Avenue	16-31-416-015-0000	R	6/17/2021 Impr-L	90892-0	\$3,500.00	\$120.00
R/R CONCRETE WALKWAY FROM END OF HOUSE TO ALLEY. R/R WALKWAY FROM REAR DOOR TO WALKWAY (GANGWAY). R/R GARAGE SERVICE WALK. ALL TO CODE. CONCRETE MUST PITCH TOWARDS OWN PROPERTY NOT NEIGHBOR'S OR CITY. WILL BE INSTALLING NEW CONCRETE SIDEWALK 7X3						
313 Robert Jr. and Doreena Velasq	1545 S. Oak Park Avenue	99-99-999-000-0059	C	6/17/2021 Impr-L	90893-0	\$4,200.00 \$185.00
INSTALL A 16' X 18' PATIO BEHIND THE BUILDING - CONCRETE MUST PITCH TOWARDS OWN PROPERTY NOT NEIGHBOR'S OR CITY.						
314 Robert & Doreena Velasquez	1543 S. Oak Park Avenue	16-19-224-047-0000	R	6/17/2021 Impr-L	90894-0	\$0.00 \$0.00
R/R SIDEWALK FROM THE FRONT GATE TO THE BACK OF THE HOUSE. CONCRETE MUST PITCH TOWARDS OWN PROPERTY NOT NEIGHBOR'S OR CITY.						
315 Roxanne M. Lavallie & June O.	2112 S. Home Avenue	16-19-327-016-0000	R	6/17/2021 Impr-L	90895-0	\$1,900.00 \$90.00
R/R FRONT STEPS.						
316 Wesley & Debra Bitner	6951 W. 30th Street	16-30-318-020-0000	R	6/17/2021 Impr-L	90896-0	\$7,986.12 \$230.00
INSTALL A OUTDOOR STAIR LIFT AT FRONT ENTRANCE - USING EXISTING POWER SUPPLY.						
317 Jose Serrano	2625 S. Grove Avenue	16-30-306-014-0000	R	6/17/2021 Roof-L	90897-0	\$11,834.64 \$315.00
TEAR OFF AND RESHINGLE THE HOUSE. R/R GUTTER ON THE HOUSE. -- DOWNSPOUTS MUST DISBURSE ONTO PRIVATE PROPERTY.						
318 Mark J. Matise	6969 W. Riverside Drive	16-30-109-032-0000	R	6/17/2021 Impr-L	90898-0	\$23,087.38 \$495.00
TEAR OFF AND RESHINGLE THE HOUSE. R/R GUTTERS ON THE HOUSE AND GARAGE. DOWNSPOUTS MUST DISBURSE ONTO PRIVATE PROPERTY.						
319 Noe Rosales Cervantes	2823 S. Ridgeland Avenue	16-29-316-012-0000	R	6/17/2021 Impr-L	90899-0	\$750.00 \$240.00
COMPLIANCE VIOLATIONS - KITCHEN SINK WATER SUPPLY HOSES NOT BE METAL GRADED TYPE, ANY OPEN LIGHT BULB FIXTURES IN CLOSETS, ROOM AND THE BASEMENT CEILING MUST BE CONVERTED TO FULL Y ENCLOSED BULB FIXTURES, ELECTRICAL OUTLETS AT LAUNDRY ARE MUST BE GFCI, EA						
320						

Report Of Building/Improvement Permits Issued By The City Of Berwyn

Thursday, July 1, 2021

Between: 6/1/2021 And 6/30/2021

Name and Address	P.I.N. #	Census Class	Permit Issued	Permit #	Cost Of Improvements	Cost Of Permit
321 Adrian Gaytan 1236 S. Grove Avenue	16-19-106-040-0000	R	6/17/2021 Impr-L	90900-0	\$100.00	\$115.00
COMPLIANCE: INSTALL EGRESS WINDOW IN BASEMENT. INSTALL HEAD SOURCE TO BASEMENT BATHROOM BY EXTENDING DUCTWORK TO BATHROOM. INSTALL COVER PLATE TO BOX IN GARAGE.						
322 Roberto & Margarita Ramirez 2116 S. Grove Avenue	16-19-330-017-0000	R	6/17/2021 HVAC-L	90901-0	\$10,000.00	\$570.00
BOILERS TO FORCED AIR HEAT IN 2 UNIT -- INSTALL 2 FURNACES AND DUCT WORK ---- NO A/C UNITS BEING INSTALL AT THIS TIME.						
323 Tawmy Avery 1510 S. Wenonah Avenue	16-19-126-016-0000	R	6/17/2021 Impr-L	90902-0	\$1,200.00	\$140.00
R/R ALLEY FENCE ON BOTH SIDES OF GARAGE W/ 4FT FENCE TO CODE. INSTALL 8" RETAINING WALL W/ BASE TO CODE. JULIE DIG #A1683438.						
324 R. & E. Vargas 2421 S. East Avenue	16-30-220-008-0000	R	6/18/2021 Bldg-B	9775-0	\$0.00	\$860.00
BUILD A NEW GARAGE, R/R DRIVEWAY AND SIDEWALK BEHIND THE HOUSE, SIDEWALK IN REAR YARD. GARAGE APRON. REMOVE NORTH SIDE FENCE FROM THE END OF HOUSE TO THE ALLEY AND INSTALL A 5FT FENCE. INSTALL FENCE BETWEEN BOTH GARAGES. HAS PERMISSION FROM 2419 EAST. REM						
325 Rigoberto Arauz 7000 W. 26th Parkway B	16-30-301-001-7001		6/18/2021 Elec-L	90657-1	\$0.00	\$50.00
ELECTRICAL SERVICE RE-INSPECTION----- REPLACE METER AND MAST TO 200 AMP.						
326 Hector & Sara Andrea Barajas 3330 S. Clinton Avenue	16-31-124-017-0000	R	6/18/2021 HVAC-L	90903-0	\$3,293.00	\$115.00
R/R FURNACE 80 EFF 90K BTU						
327 Juanita Madrigal 2616 S. Harvey Avenue	16-29-302-025-0000	R	6/18/2021 HVAC-L	90904-0	\$10,582.00	\$275.00
R/R FURNACE 80% EFF 70K BTU. R/R AC 13 SEER 2 TON. R/R WATER HEATER. A/C CONDENSERS MUST BE LOCATED BEHIND THE HOUSE 3' FROM PROPERTY LOT LINE AND ELECTRICAL METER. WATER HEATERS REQUIRE EXPANSION TANKS.						
328 AMANDA MILLER 3240 S. Maple Avenue	16-31-108-041-0000	R	6/18/2021 Roof-L	90905-0	\$4,500.00	\$125.00
R/R HOUSE SHINGLE ROOF TO CODE. ICE & WATER SHIELD TO CODE. NO POWER VENTS.						

Report Of Building/Improvement Permits Issued By The City Of Berwyn

Thursday, July 1, 2021

Between: 6/1/2021 And 6/30/2021

Name and Address	P.I.N. #	Census Class	Permit Issued	Permit #	Cost Of Improvements	Cost Of Permit
Jose I. & Hortencia Ibarra 1401 S. Clarence Avenue	16-19-219-001-0000	R	6/18/2021 Impr-L	90906-0	\$16,500.00	\$390.00
T/O & RE-ROOF HOUSE & GARAGE SHINGLE ROOFS TO CODE. R/R SOFFITS, FASCIAS, & GUTTERS. R/R SIDING ON GARAGE. R/R SIDING ON HOUSE DORMER. NO POWER VENTS. ICE AND WATER SHIELD TO CODE.						
329 Thomas & Wanda I. Cintron 1447 S. East Avenue	16-19-220-020-0000	R	6/18/2021 Fence-L	90907-0	\$2,920.00	\$135.00
REMOVING AND REPLACING EXISTING FENCE ON THE SOUTH SIDE OF PROPERTY (STREET SIDE) FROM REAR OF HOUSE TO THE GARAGE. FENCE WILL BE 5FT IN HEIGHT.						
330 Robert J. Bain & Deborah J. Ba 2231 S. Clarence Avenue	16-30-203-017-0000	R	6/18/2021 Impr-L	90908-0	\$9,779.00	\$200.00
REMOVE AND RPELACE ROOF ON THE HOUSE AND DETACHED GARAGE WITH SHINGLES,, ICE AND WATER SHIELD.						
331 Alejandro & Estela Martinez 3546 S. Lombard Avenue	16-32-303-040-0000	R	6/18/2021 Impr-L	90909-0	\$500.00	\$0.00
TUCKPOINTING ON THE HOUSE AS NEEDED.						
332 Dakun Huang and Hua Lian Ca 1231 S. Clarence Avenue	16-19-203-016-0000	R	6/18/2021 Fence-L	90910-0	\$3,500.00	\$135.00
R/R NORTH SIDE FENCE W/ 5FT + 1FT OPEN LATTICE FENCE. R/R SOUTH SIDE FENCE (NEIGHBOR PERMISSION ON FILE) W/ 5FT + 1FT OPEN LATTICE FENCE. R/R ALLEY GATE & FENCE W/ 6FT SOLID FENCE.						
333 Jennifer M. Kelliher 2322 S. Scoville Avenue	16-30-212-023-0000	R	6/18/2021 Impr-L	90911-0	\$17,328.00	\$480.00
R/R SIDEWALK ON THE SOUTH SIDE OF THE GARAGE, R/R GARAGE SLAB, R/R SIDEWALK BEHIND TH EHOUSE. R/R YARD SECTION OF DRIVEWAY AND SECTION OF THE RIVEWAY ALONG THE HOUSE. REMOVING AND REPLACING GARAGE OVERHEAD DOOR 16X17. DUMPSTERS/PODS REQUIRE A FLASHING BA						
334 Felicity & George Rodriguez 3514 S. Wisconsin Avenue	16-31-301-020-0000	R	6/18/2021 Impr-L	90912-0	\$10,350.00	\$225.00
TEAR OFF EXISTING SIDING, WRAP WITH MOPISTURE BARRIER, INSTALL NEW VINYL SIDING. -HOUSE						
335 Rebecca Sosa 2410 S. Clinton Avenue	16-30-109-017-0000	R	6/18/2021 Impr-L	90913-0	\$0.00	\$40.00
INSTALL POOL AT REAR OF PROPERTY TO CODE.						
336 John & Alicia Brucato 1833 S. Harvey Avenue	16-20-311-013-0000	R	6/18/2021 Impr-L	90914-0	\$7,200.00	\$150.00
INSTALL A 6" BACK WATER VALVE ALSO 6" CLEAN OUT IN FRONT YARD (PRIVATE PROPERTY). INSTALL 48" CONCRETE BASIN.						
337						

Report Of Building/Improvement Permits Issued By The City Of Berwyn

Thursday, July 1, 2021

Between: 6/1/2021 And 6/30/2021

Name and Address	P.I.N. #	Census Class	Permit Issued	Permit #	Cost Of Improvements	Cost Of Permit
338 David L. Wagge Sr. & Angela 3126 S. Clinton Avenue	16-31-104-024-0000	R	6/18/2021 Impr-L	90915-0	\$1,200.00	\$0.00
339 Soledad Morales 1337 S. Wesley Avenue	16-19-210-017-0000	R	6/18/2021 Impr-L	90916-0	\$1,200.00	\$90.00
340 Erasto Rodriquez 2347 S. Scoville Avenue	16-30-213-016-0000	R	6/18/2021 Fence-L	90917-0		\$135.00
341 Stephen Lancsak & Janet Lans 1246 S. Home Avenue	16-19-103-044-0000	R	6/18/2021 Roof-L	90918-0	\$13,880.29	\$295.00
342 Jessica Ruiz -meza 2410 S. Wesley Avenue	16-30-217-021-0000	R	6/18/2021 Roof-L	90919-0	\$15,453.80	\$290.00
343 Rosalba Barrios 3843 S. Home Avenue	16-31-328-030-0000	R	6/18/2021 Roof-L	90920-0	\$6,500.00	\$155.00
344 William Osetek 3534 S. Home Avenue	16-31-303-030-0000	R	6/18/2021 HVAC-L	90921-0	\$3,675.00	\$140.00
345 Octaviano Mendoza & Azusena 1308 S. Ridgeland Avenue	16-19-215-052-0000	R	6/18/2021 Impr-L	90922-0	\$3,000.00	\$105.00
346 The 1825 Kenilworth Trust 1825 S. Kenilworth Avenue	16-19-314-011-0000	R	6/18/2021 Impr-L	90923-0	\$3,325.00	\$70.00

Report Of Building/Improvement Permits Issued By The City Of Berwyn

Thursday, July 1, 2021

Between: 6/1/2021 And 6/30/2021

Name and Address	P.I.N. #	Census Class	Permit Issued	Permit #	Cost Of Improvements	Cost Of Permit
Love Real Estate Solutions LL 2335 S. Scoville Avenue	16-30-213-012-0000	R	6/21/2021 Bldg-B	9767-0	\$150,000.00	\$5,105.00
INTERIOR REMODEL WITH 2ND FLOOR ADDITION, NEW 20'X20'X16'(H) GARAGE. 1ST FLOOR WILL CONSIST OF KITCHEN, DINING ROOM, LIVING ROOM, POWDER ROOM, PANTRY, BREAKFAST AREA AND DEN AREA. THE 2ND FLOOR WILL CONSIST OF 3 NEW BEDROOMS, A NEW FULL BATHROOM, A NEW 3/						
347						
Agustin & Eve Rogel 3744 S. Lombard Avenue	16-32-319-039-0000	R	6/21/2021 Impr-L	90924-0	\$5,780.00	\$175.00
CHISEL OUT CRACKS AND LOOSE MORTAR AND PARGING BRICKS. TUCKPOINT ENTIRE HOUSE COMPLETELY.						
348						
JORGE & MARIA CURIEL 6436 W. 27th Place	16-30-411-018-0000	R	6/21/2021 Fence-L	90925-0	\$3,526.00	\$135.00
REMOVING AND REPLACING FENCE FROM THE REAR OF HOUSE TO THE ALLEY 5FT+1FT OPEN LATTICE ON THE WEST SIDE, REMOVING AND REPLACING FENCE FROM BACK OF HOUSE TO THE ALLEY ON THE EAST SIDE OF PROPERTY 5FT+1FT OPEN LATTICE WITH NEIGHBOR PERMISSION.. REMOVING AND						
349						
Alan Bardauskis 3424 S. Euclid Avenue	16-31-229-023-0000	R	6/21/2021 Impr-L	90926-0	\$6,700.00	\$140.00
REMOVE THE OLD STAIRS IN THE FRONT AND REAR OF THE HOUSE. REBUILD NEW STAIRS USING TREATED LUMBER. REPLACING CONCRETE IN THE FRONT APPROX. 4'X10' AND IN THE REAR APPROX 10'X10'						
350						
Ralph Householder 3816 S. Lombard Avenue	16-32-327-034-0000	R	6/21/2021 Elec-L	90927-0	\$800.00	\$140.00
REPAIR OR REPLACE GFCI OUTLET BASEMENT BATHROOM. REPAIR OR REPLACE 2 OPEN BULB LIGHTS IN BASEMENT LAUNDRY ROOM. ADD SWITCH IN LAUNDRY ROOM. ATF FOR RECESSED LIGHTING IN LIVING ROOM.						
351						
NICOLE WALLACE EL 3820 S. Ridgeland Avenue	16-31-424-066-0000	R	6/21/2021 Plum-L	90928-0	\$7,821.42	\$255.00
SEWER REPAIR LOCATED IN PARKWAY. CLEAN OUT CANNOT BE INSTALLED IN PARKWAY.						
352						
Victoria Luna 3232 S. Clarence Avenue	16-31-217-023-0000	R	6/21/2021 Impr-L	90929-0	\$12,485.00	\$455.00
EXTERIOR SEWER FLOOD CONTROL SYSTEM, SIMPLEX OUTLET IN VAULT ON DEDICATED 20 AMP CIRCUIT. 1 INTERIOR FOUNDATION CRACK REPAIR. NO DISCHARGE. CHECK VALVE OVER SEWER LINE TO VAULT.						
353						

Report Of Building/Improvement Permits Issued By The City Of Berwyn

Thursday, July 1, 2021

Between: 6/1/2021 And 6/30/2021

Name and Address	P.I.N. #		Census Class	Permit Issued	Permit #	Cost Of Improvements	Cost Of Permit
David Torrez and Melissa Torr 2525 S. Clinton Avenue	16-30-115-010-0000	R/R FURNACE. R/R AC. A/C CONDENSERS MUST BE LOCATED BEHIND THE HOUSE 3' FROM PROPERTY LOT LINE AND ELECTRICAL METER.	R	6/21/2021 HVAC-L	90930-0	\$7,730.00	\$190.00
354 Maria Teresa Lozano 3742 S. Cuyler Avenue	16-32-316-034-0000	REMOVIGN AND REPLACING FENCE FROM REAR OF HOUSE TO CONNECT TO END OF GARAGE 5FT+1FT OPEN LATTICE. REMOVING AND REPLACING FENCE ON THE STREET SIDE FROM END OF HOUSE TO THE GARAGE 5FT+1FT OPEN LATTICE.	R	6/21/2021 Fence-L	90931-0	\$9,530.00	\$135.00
355 Fabricio & Carolina Nava 3306 S. Wesley Avenue	16-31-222-017-0000	INSTALLING FENCE/GATE AT THE FRONT OF THE PROPERTY ON BOTH SIDES 5FT+1FT OPEN LATTICE. INSTALLING GATES ON BOTH SIDES OF THE GARAGE USING OWN POSTS 5FT+1FT OPEN LATTICE.	R	6/21/2021 Fence-L	90932-0	\$4,830.00	\$135.00
356 Rene A. Bernal & Maria T. Bern 1836 S. Cuyler Avenue	16-20-308-031-0000	INSTALL A 5FT + 1FT OPEN LATTICE FENCE ON THE NORTH SIDE OF THE PROPERTY FROM THE END OF THE HOUSE TO FRONT OF GARAGE. INSTALL A 5FT + 1FT OPEN LATTICE FENCE FROM HOUSE TO HOUSE AT THE FRONT OF THE PROPERTY MUST BE AT LEAST 15FT BACK FROM THE FRONT LOT LI	R	6/21/2021 Fence-L	90933-0	\$2,500.00	\$0.00
357 Jaime & Anna Borjas 3505 S. Highland Avenue	16-32-302-003-0000	INSTALL A 14'X14' GAZEBO/PERGOLA ON 42" DEEP PIERS. - MUST BE AT LEAST 3FT OFF THE LOT LINE AND CAN NOT NO TALLER THAN 12'	R	6/21/2021 Impr-L	90934-0	\$1,000.00	\$190.00
358 Louis & Rebekah Holland 3443 S. Clinton Avenue	16-31-133-015-0000	TUCKPOINT ENTIRE FOUNDATION. CHISEL OUT OLD MORTAR 1 1/2 INCHES DEEP AND RE-TUCKPOINT. WATER PROOF AFTER MORTAR CURES.	R	6/21/2021 Impr-L	90935-0	\$2,400.00	\$130.00
359 John Bax & Amy Johnson 3515 S. Grove Avenue	16-31-307-005-0000	INSTALL A 34" CHAIN LINK FENCE ON THE WEST SIDE OF THE PROPERTY -IN THE AREA WHERE THE GARAGE USE TO BE.	R	6/21/2021 Fence-L	90936-0	\$750.00	\$135.00
360 Brian Nagl 3643 S. Highland Avenue	16-32-310-012-0000	ELECTRICAL GFI IN LAUNDRY ROOM, OUTLET IN BEDROOM, GARAGE OUTLET.	R	6/21/2021 Elec-L	90937-0	\$150.00	\$100.00
361							

Report Of Building/Improvement Permits Issued By The City Of Berwyn

Thursday, July 1, 2021

Between: 6/1/2021 And 6/30/2021

Name and Address	P.I.N. #	Census Class	Permit Issued	Permit #	Cost Of Improvements	Cost Of Permit
362 Kenosha A King 1940 S. Clarence Avenue	16-19-418-029-0000	R	6/21/2021 Elec-L	90938-0	\$6,032.00	\$165.00
REPLACE 3 METER WITH 4 METER SOCKET WITH BREAKER. REPLACE 3 PANEL WITH NEW ONCE AND ADD ONE FOR PUBLIC PANEL.						
363 Maria J. & Victor A. Barahona 1303 S. Clarence Avenue	16-19-211-012-0000	R	6/21/2021 Roof-L	90939-0	\$8,100.00	\$170.00
REMOVE AND REPLACE APPROX 18-19 SQUARES OF SHINGLES AND UNDERLAYMENT. WILL BE USING GAF TIMERLINE HDZ SHINGLES, DRIP EDGE, ROOF FLASHINGS, PIPES, AND VENTS. ICE AND WATER SHIELD. --- HOUSE						
364 Sean Sullivan 3823 S. Kenilworth Avenue	16-31-330-010-0000	R	6/22/2021 Gar-B	9776-0	\$22,427.25	\$0.00
DEMO AND REBUILD A 20' X 20' X 16" PITCHED ROOF GARAGE.						
365 Berwyn Bottega Co 6712 W. Cermak Road	16-19-425-025-0000	C	6/22/2021 Impr-L	79058-2	\$0.00	\$50.00
paying for additional RPZ inspection.						
366 IH3 Property Illinois, LLC 2824-26 S. Harvey Avenue	16-29-318-030-0000	R	6/22/2021 Impr-L	90784-1	\$0.00	\$50.00
PAYING FOR PRE-POUR RE-INSPECTION-----ATF - R/R SIDEWALK ALONG THE NORTHSIDE OF THE HOUSE. CONCRETE MUST PITCH TOWARDS OWN PROPERTY NOT NEIGHBOR'S OR CITY.						
367 Juan Aguirre & Sandra Garcia 1920 S. Wesley Avenue	16-19-417-023-0000	R	6/22/2021 Plum-L	90846-1	\$0.00	\$50.00
PAYING FOR ELECTRIC ROUGH RE-INSPECTION-----INSTALLING A FLOOD CONTROL ON A SEPARATE CIRCUIT.						
368 Esteban & Susana Rivas 1930 S. Maple Avenue	16-19-316-029-0000	R	6/22/2021 Fence-L	90940-0	\$2,542.00	\$135.00
REMOVE AND REPLACE THE FENCE ON THE NORTH SIDE OF PROPERTY FROM THE END OF HOUSE TO THE END OF GARAGE AND ALONG ALLEY INSTALL 5FT+1FT OPEN LATTICE. HAS JULIE DIG # ATTACHED.						
369 Kevin A. Sadowski 1314 S. Highland Avenue	16-20-108-022-0000	R	6/22/2021 Fence-L	90941-0	\$500.00	\$135.00
INSTALLING FENCE ON THE NORTH SIDE OF PROPERTY FROM REAR OF HOUSE TO THE GARAGE 4FT CHAIN LINK. INSTALLING GATE TO ENCLOSE DRIVEWAY ON THE SOUTH SIDE 4FT CHAIN LINK.						
370 Maria Del Carmen Lozano 2744 S. Oak Park Avenue	16-30-313-106-0000	R	6/22/2021 Impr-L	90942-0	\$750.00	\$140.00
ATF- INSTALLED RECESSED LIGHTING IN LIVING ROOM. INSTALLING EGRESS WINDOW IN THE BASEMENT. BRING WINDOWS TO EGRESS CODE WHERE NEEDED.						

Report Of Building/Improvement Permits Issued By The City Of Berwyn

Thursday, July 1, 2021

Between: 6/1/2021 And 6/30/2021

Name and Address	P.I.N. #	Census Class	Permit Issued	Permit #	Cost Of Improvements	Cost Of Permit
alexander D. & Kristy M. Basse 3327-29 S. Wesley Avenue	16-31-223-014-0000	R	6/22/2021 Fence-L	90943-0	\$7,600.00	\$135.00
NORTH---REMOVE FENCE FROM MID OF HOUSE TO REAR OF HOUSE & ALONG THE GARAGE. REPLACE THE FENCE FROM THE END OF THE HOUSE TO FRONT OF GARAGE. SOUTH---REMOVE THE FENCE THAT RUNS FROM THE REAR CORNER OF THE HOUSE TO THE ALLEY. NEW FENCES BEING INSTALLED WILL						
371 Momcilo Ryan 3537 S. Kenilworth Avenue	16-31-306-017-0000	R	6/22/2021 Fence-L	90944-0	\$4,100.00	\$135.00
REMOVE AND REPLACING FENCE ON THE NORTH SIDE FROM BACK OF HOUSE TO THE ALLEY 5FT+1FT OPEN LATTICE. INSTALLING FENCE/GATE ON THE SOUTH SIDE REAR OF HOUSE 6FT SOLID. JULIE DIG# ATTACHED.						
372 Jose J. Navarrete 3633 S. Elmwood Avenue	16-31-414-014-0000	R	6/22/2021 Impr-L	90945-0	\$4,000.00	\$120.00
R.R CONCRETE STAIRS. R/R FRONT CONCRETE APPROACH. CONCRETE MUST PITCH TOWARDS OWN PROPERTY NOT NEIGHBOR'S OR CITY.						
373 Brendon Halm & Katherine O'M 3825 S. Cuyler Avenue	16-32-325-004-0000	R	6/22/2021 Impr-L	90946-0	\$3,000.00	\$105.00
R/R FRONT CONCRETE STAIRS TO CODE. CONCRETE MUST PITCH TOWARDS OWN PROPERTY NOT NEIGHBOR'S OR CITY.						
374 Claudia R Mamani 3244 S. Cuyler Avenue	16-32-111-042-0000	R	6/22/2021 Impr-L	90947-0	\$4,500.00	\$300.00
COMPLIANCE- STAIRS TO 2ND LEVEL MUST HAVE HANDRAILS INSTALLED TO CODE. STAIRWAY REQUIRES ATLEAST ONE SIDE OR EACH CONTINUOUS RUN OF TREADS HANDRAIL HEIGHT TO BE NO LESS THAN 34 INCHES AND NO MORE THAN 38INCHES MEASURE VERTICALLY FROM THE TREAD NOSING, REP						
375 Rocio Melero 2401 S. Scoville Avenue	16-30-221-001-0000	R	6/22/2021 Roof-L	90948-0	\$13,275.22	\$295.00
T/O & RE-ROOF HOUSE AND GARAGE SHINGLE ROOFS TO CODE. NO POWER VENTS. ICE AND WATER SHIELD TO CODE.						
376 Hector Garcia & Elsa Alejandra 6337 W. 26th Street	16-29-124-031-0000	C	6/22/2021 Impr-L	90949-0	\$950.00	\$40.00
TUCKPOINTING GROUND LEVEL ONLY						
377 Julio Chiquito & Phillip Rodrigu 3747 S. Grove Avenue	16-31-323-017-0000	R	6/22/2021 Impr-L	90950-0	\$1,663.00	\$90.00
R/R TWO (2) WINDOWS IN ATTIC AND BASEMENT. BRING WINDOWS TO EGRESS CODE WHERE NEEDED.						
378						

Report Of Building/Improvement Permits Issued By The City Of Berwyn

Thursday, July 1, 2021

Between: 6/1/2021 And 6/30/2021

Name and Address	P.I.N. #	Census Class	Permit Issued	Permit #	Cost Of Improvements	Cost Of Permit
379 Maria Garcia 1520 S. Oak Park Avenue	16-19-131-031-0000	R	6/22/2021 Impr-L	90951-0	\$8,300.00	\$195.00
REPLACE TWELVE (12) WINDOWS. TWO (2) IN KITCHEN, THREE (3) IN DINING ROOM, ONE (1) BATHROOM, TWO (2) IN BEDROOM. BRING WINDOWS TO EGRESS CODE WHERE NEEDED.						
380 Mr. Jandris 3235 S. Cuyler Avenue	16-32-112-016-0000	R	6/22/2021 Impr-L	90952-0	\$3,380.00	\$70.00
REPLACE FOUR (4) WINDOWS IN LIVING ROOM.						
381 Jose J Plascencia Jr. 3706 S. Clarence Avenue	16-31-417-108-0000	R	6/22/2021 Impr-L	90953-0	\$5,000.00	\$135.00
REMOVING AND REPLACING FRONT WINDOWS ON BOTH FLOORS. REPLACING FRONT APPROACH (EXISTING-PIC ATTACHED)						
382 Joseph & Theresa Maki 3544 S. Scoville Avenue	16-31-404-031-0000	R	6/22/2021 Impr-L	90954-0	\$0.00	\$0.00
PRE-LIMINARY FOR EGRESS WINDOWS--- MEASURE CHECK SIZE						
383 Robert & Genevieve Bianco 6928 W. 29th Street	16-30-317-039-0000	R	6/22/2021 Roof-L	90955-0	\$7,212.00	\$40.00
SHINGLE TEAR OFF OLD ROOF AND NEW ROOF TO BE INSTALLED. DUMPSTER ON THE STREET. DUMPSTERS/PODS REQUIRE A FLASHING BARRICADE ON THE SIDE OF INCOMMING TRAFFIC.						
384 Loyola University Health Syste 3249 S. Oak Park Avenue	16-31-215-016-0000	C	6/22/2021 Impr-L	90956-0	\$39,234.46	\$660.00
ASPHALT PATCH 2,900 SF IN 9 AREAS, CRACK SEAL 11,995 SF, SEALCOAT 118,852 SF AND LOT MARK 315 STALLS, 32 ADA AND 38 ARROWS.						
385 Lisa M. Ortiz 3715 S. Clinton Avenue	16-31-321-005-0000	R	6/22/2021 Fence-L	90957-0		\$135.00
R/R NORTH SIDE FENCE W/ 5FT + 1FT OPEN LATTICE FENCE (NEIGHBOR PERMISSION ON FILE). R/R SOUTH SIDE FENCE W/ 5FT + 1FT OPEN LATTICE FENCE. R/R GATE AND FENCE AT END OF HOUSE W/ 5FT + 1FT OPEN LATTICE FENCE.						
386 Adrienne Linzemann 3001 S. Oak Park Avenue	16-30-415-001-0000	R	6/22/2021 Elec-L	90958-0	\$0.00	\$0.00
CHANGE OUTLETS IN THE KITCHEN.						
387 Alberto & Melania Canelo 6534 W. 27th Place	16-30-411-006-0000	R	6/22/2021 Roof-L	90959-0	\$2,500.00	\$150.00
TEAR OFF AND RESHINGLE THE HOUSE AND GARAGE. NO POWER VENTS ICE AND WATER SHIELD TO CODE						

Report Of Building/Improvement Permits Issued By The City Of Berwyn

Thursday, July 1, 2021

Between: 6/1/2021 And 6/30/2021

Name and Address	P.I.N. #	Census Class	Permit Issued	Permit #	Cost Of Improvements	Cost Of Permit
Rogelio & Silvia Oseguera 2635 S. Home Avenue	16-30-303-023-0000	R	6/22/2021 Impr-L	90963-0	\$5,000.00	\$135.00
REMOVE THE SIDEWALK FROM THE BACK OF THE HOUSE TO THE ALLEY AND REPLACE WITH PAVERS- ALSO INCREASING THE WIDTH BY 1 FT. REMOVE EXISTING PATIO AND INSTALL A 26' X 12' PAVER PATIO BEHIND THE HOUSE. MUST PITCH TOWARDS OWN PROPERTY NOT NEIGHBOR'S OR CITY.						
388 ISAAC OSIO 1448 S. Gunderson Avenue	16-19-221-040-0000	R	6/23/2021 Bldg-B	9778-0	\$2,000.00	\$665.00
ATF: INSTALLED BATHROOM IN BASEMENT.						
389 Claudia R Mamani 3244 S. Cuyler Avenue	16-32-111-042-0000	R	6/23/2021 Impr-L	90960-0	\$10,944.00	\$225.00
INSTALLATION OF ROOFTOP SOLAR PANELS - MUST HAVE TAP CONNECTORS						
390 Ezequie Medina 6523 W. 27th Place	16-30-410-034-0000	R	6/23/2021 Impr-L	90961-0	\$12,996.00	\$255.00
INSTALLATION OF ROOF TOP SOLAR PANELS AND ELECTRICAL SERVICE UP TO CODE - MUST HAVE TAP CONNECTORS						
391 OCTAVIO & ANN TORRES 2222 S. Grove Avenue	16-30-103-028-0000	R	6/23/2021 Impr-L	90962-0	\$11,628.00	\$240.00
INSTALLATION OF ROOFTOP SOLAR PANELS AND ELECTRICAL SERVICE UPGRADE -MUST HAVE TAP CONNECTORS.						
392 Ariel Bolles & Spencer Ham 3432 S. Grove Avenue	16-31-134-024-0000	R	6/23/2021 Plum-L	90964-0	\$8,800.00	\$300.00
INSTALL 1" WATER SERVICE. JULIE DIG #A0981345						
393 Victor & Maria Aviles 2614 S. Harvey Avenue	16-29-302-024-0000	R	6/23/2021 Roof-L	90965-0	\$720.00	\$40.00
T/O 26FT OF RIDGE CAPS. OPEN 3" OF WOOD. INSTALL RIDGE VENT AND CAP.						
394 Garcia & Robles 2513 S. Highland Avenue	16-29-126-006-0000	R	6/23/2021 Impr-L	90966-0	\$575.00	\$140.00
ADD GARAGE DOOR/PARTY DOOR 8X7						
395 Lawrence Solnes 3619 S. Gunderson Avenue	16-31-413-008-0000	R	6/23/2021 Dump-L	90967-0	\$0.00	\$50.00
DUMPSTER ON STREET. DUMPSTERS/PODS REQUIRE A FLASHING BARRICADE ON THE SIDE OF INCOMMING TRAFFIC.						
396 David Liesse, Trustee of the Da 3531 S. Kenilworth Avenue	16-31-306-045-0000	R	6/23/2021 HVAC-L	90968-0	\$7,335.00	\$140.00
A/C REPL 13 SEER 2 TON 3FT FROM PROPERTY LINE.						
397 Gerald & Denise Zabojsnik 3437 S. Oak Park Avenue	16-31-229-014-0000	R	6/23/2021 HVAC-L	90969-0	\$5,683.00	\$140.00
A/C REPL 13 SEER 3 TON 3FT FROM PROPERTY LINE						
398						

Report Of Building/Improvement Permits Issued By The City Of Berwyn

Thursday, July 1, 2021

Between: 6/1/2021 And 6/30/2021

Name and Address	P.I.N. #	Census Class	Permit Issued	Permit #	Cost Of Improvements	Cost Of Permit
1224 Grove Berwyn LLC 1224 S. Grove Avenue	16-19-106-034-0000	R	6/23/2021 Elec-L	90970-0	\$1,600.00	\$140.00
INSTALLING 2 GFCI'S IN GARAGE, REMOVE 1/2 EMT GOING IN TO GROUND, DIG TRENCH 18" DEEP FROM HOUSE TO GARAGE, REMOVE OVERHEAD POWER FOR GARAGE.						
399 6822 Windsor, LLC 6822-36 W. Windsor Avenue	16-31-126-005-0000	C	6/23/2021 Impr-L	90971-0	\$3,800.00	\$170.00
INSTALL FIRE SUPPRESSION SYSTEM TO EXISTING KITCHEN HOOD.						
400 Steven Kenneth Kuhn and Cath 1304 S. Scoville Avenue	16-19-212-025-0000	R	6/23/2021 Impr-L	90972-0	\$3,740.00	\$120.00
INSTALL 170SQ FT PAVER APTIO IN THE BACKYARD. JULIE DIG # ATTACHED.						
401 Maribel Arenas 3630 S. Euclid Avenue	16-31-400-043-0000	R	6/23/2021 Fence-L	90973-0	\$6,000.00	\$135.00
R/R NORTH SIDE FENCE W/ 5FT + 1FT OPEN LATTICE VINYL FENCE (NEIGHBOR PERMISSION ON FILE). R/R ALLEY FENCE W/ 6FT SOLID VINYL FENCE CONNECTING GARAGE & NEIGHBOR'S GARAGE (NEIGHBOR PERMISSION ON FILE). JULIE DIG #X1671184.						
402 7050 Ogden LLC 7050 W. Ogden Avenue	99-99-999-000-0256	C	6/23/2021 Elec-L	90974-0	\$3,600.00	\$120.00
INSTALL 2 EV CHARGERS. 1 ON OUTSIDE OF BUILDING & 1 IN MECHANIC BAY.						
403 Enrique Sanchez 1843 S. Cuyler Avenue	16-20-309-014-0000	R	6/23/2021 Impr-L	90975-0	\$400.00	\$240.00
REMOVE THE NORTH SIDE FENCE FROM THE END OF THE HOUSE TO THE ALLEY AND INSTALL 5FT+1FT OPEN LATTICE. REMOVE AND INSTALL A 6FT FENCE ALONG THE THE ALLEY. ON THE SOUTH SIDE INSTLL A 5FT+1FT OPEN LATTICE FENCE ALONG THE DRIVEWAY FROM THE REAR CORNER OF THE H						
404 Mario Villegas & Luis A. Pinto 1415 S. East Avenue	16-19-220-007-0000	R	6/23/2021 Impr-L	90976-0	\$3,600.00	\$145.00
TUCKPOINT WHOLE HOUSE AS NEEDED. REPLACE 16 BRICKS. IF GRINDING MUST TENT OR TARP AREA. WET GRINDING IS ALSO ALLOWED.						
405 LUIS ARREOLA & MARIA SAN 3721 S. Grove Avenue	16-31-323-042-0000	R	6/23/2021 Impr-L	90977-0	\$4,500.00	\$400.00
COMPLIANCE VIOLATIONS - ALL WINDOWS MUST BE FULLY OPERABLE AND IN GOOD REPAIR, REPLACE TUB SURROUND WALLS WITH WATER TYPE MATERIAL TO CODE, REPLACE ALL RUSTING PLUMBING WHERE NEEDED, BASEMENT BATHROOM MUST HAVE A PERMEANT CONTROLLABLE HEAT SOURCE INSTALLE						
406						

Report Of Building/Improvement Permits Issued By The City Of Berwyn

Thursday, July 1, 2021

Between: 6/1/2021 And 6/30/2021

Name and Address	P.I.N. #	Census Class	Permit Issued	Permit #	Cost Of Improvements	Cost Of Permit
407 Roberto Montano 3601 S. Highland Avenue	16-32-310-033-0000	R	6/23/2021 Fence-L	90978-0	\$1,800.00	\$135.00
INSTALL A 5FT + 1FT OPEB LATTICE FENCE BETWEEN THE TWO HOUSES TOWARDS THE FRONT. THIS FENCE MUST BE AT LEAST 15FT BACK FROM THE FRONT OF THE PROPERTY (LOT LINE). INSTALL A 6FT FENCE BETWEEN THE TWO GARAGES. INSTALL A 6FT SOLID FENCE AT NORTH SIDE OF PROPE						
408 Fanny Huang 3513 S. Wisconsin Avenue	16-31-302-009-0000	R	6/23/2021 Impr-L	90979-0	\$5,000.00	\$235.00
INSTALL 15 x 15 COMPOSITE DECK IN YARD. MUST SIT ON 42" DEEP PIERS. JULIE DIG #A1743440						
409 Miguel & Alejandra Hernandez 6912 W. Riverside Drive	16-30-110-002-0000	R	6/23/2021 Impr-L	90980-0	\$8,000.00	\$300.00
INSTALL NEW 1" COPPER WATER SERVICE.						
410 Frances Henrix 1819 S. Grove Avenue	16-19-315-008-0000	R	6/23/2021 Roof-L	90981-0	\$6,200.00	\$155.00
REROOF THE BUILDING WITH MOD BIT.						
411 Gustavo & Elizabeth Chavez 1638 S. Elmwood Avenue	16-19-406-017-0000	R	6/23/2021 Roof-L	90982-0	\$8,750.00	\$185.00
FLAT ROOF TEAR OFF AND INSTALL 1/2" INSULATION, LIBERTY BASE AND MOD BIT TORCH DOWN.						
412 Jose Ortiz 1303 S. Euclid Avenue	16-19-209-002-0000	R	6/23/2021 Impr-L	90983-0	\$600.00	\$90.00
INSTALL EGRESS WINDOW IN BASEMENT TO CODE. REPAIR LIGHT SWITCH FOR BASEMENT BEDROOM CLOSET. PATCH & PAINT BASEMENT DRYWALL AS NEEDED. ENCLOSE OPEN LIGHT BULBS IN FURNACE ROOM.						
413 Natali Gonzales-Nazario 6433 W. 34th Street	16-31-228-023-0000	R	6/24/2021 Gar-B	9779-0	\$10,000.00	\$325.00
DEMO EXISTING GARAGE AND BUILDING NEW 24X22X16(HEIGHT) GARAGE						
414 Fermin & Carmen Rodriguez 2711 S. Wesley Avenue	16-30-408-006-0000	R	6/24/2021 Impr-L	88349-2	\$0.00	\$50.00
PLUMBING ROUGH RE-INSPECTION FEE ONLY (INSP PASSED ALREADY)						
415 Jean Miller 1507 S. Maple Avenue	16-19-125-003-0000	R	6/24/2021 Elec-L	90984-0	\$5,990.00	\$40.00
INSTALL NEW 3 GANG METER FITTING, INSTALL 200 AMP RISER, INSTALL PUBLIC PANEL, PROPERLY GROUNDED SERVICE TO CODE, INSTALL EMERGENCY LIGHT FRONT AND REAR HALLWAYS.						

Report Of Building/Improvement Permits Issued By The City Of Berwyn

Thursday, July 1, 2021

Between: 6/1/2021 And 6/30/2021

Name and Address	P.I.N. #	Census Class	Permit Issued	Permit #	Cost Of Improvements	Cost Of Permit
<u>416</u> Esther Sanchez & Maria Avila 1829 S. Clinton Avenue	16-19-313-011-0000	R	6/24/2021 Elec-L	90985-0	\$1,150.00	\$40.00
REPLACE KITCHEN GFCI OUTLETS WITH NEW GFCI OUTLETS, REPLACE LAUNDRY OUTLETS WITH GFCI OUTLETS. INSTALL ELECTRICAL BASEBOARD HEATERS IN 1ST FLOOR BATHROOM. REPLACE 2ND FLOOR BATHROOM EXHAUST FAN WITH A BATH FAN WITH HEATER.						
<u>417</u> Consuelo & Anselmo Saucedo 2840 S. Lombard Avenue	16-29-319-036-0000	R	6/24/2021 Fence-L	90986-0	\$1,300.00	\$135.00
REMOVING AND REPLACING FENCE ON THE NORTH SIDE OF PROPERTY FROM REAR OF HOUSE TO THE END OF GARAGE 5FT+1FT OPEN LATTICE . HAS NEIGHBOR PERMISSION FROM 2838 LOMBARD.						
<u>418</u> Jose & Lucila Abraham 2114 S. Wenonah Avenue	16-19-326-017-0000	R	6/24/2021 Roof-L	90987-0	\$13,800.00	\$260.00
SHINGLE ROOF TEAR OFF ON DWELLING AND DETACHED GARAGE, WRAP WINDOWS IN ALUMINUM, MINOR VINYL SIDING REPAIRS ON GARAGE, DOWNSPOUT REPAIRS ON SOUTH GUTTERS.						
<u>419</u> 6700 W 26th Street 6700 W. 26th Street 0	99-99-999-000-0619		6/24/2021 Impr-L	90988-0	\$30,000.00	\$0.00
RUNNING GAS MAIN						
<u>420</u> Michael Emery & Evelyn Perez 6406 W. 32nd Street	16-31-214-036-0000	R	6/24/2021 Impr-L	90989-0	\$2,839.00	\$105.00
R/R GUTTERS & DOWNSPOUTS ON THE HOUSE.						
<u>421</u> William & Dolore Williams 3508 S. Harvey Avenue	16-32-302-030-0000	R	6/24/2021 Impr-L	90990-0	\$3,049.00	\$120.00
R/R GUTTERS & DOWNSPOUTS AT PROPERTY. DOWNSPOUTS MUST DISBURSE ONTO PRIVATE PROPERTY.						
<u>422</u> Trevor & Nicoline M.E Shoffer 2322 S. Wesley Avenue	16-30-209-026-0000	R	6/24/2021 Impr-L	90991-0	\$280.00	\$40.00
R/R DOWNSPOUT ON BACK RIGHT SIDE OF THE HOME & WILL DRAIN INTO RAIN BARREL.						
<u>423</u> Michael D. Chester 2718 S. Harvey Avenue	16-29-310-028-0000	R	6/24/2021 Impr-L	90992-0	\$0.00	\$375.00
SOLAR PANEL INSTALLATION ON TOP OF THE HOUSE.						
<u>424</u> Ezequiel & Carmen O. Holguin 2310 S. Lombard Avenue	16-29-111-024-0000	R	6/24/2021 Impr-L	90993-0	\$21,100.00	\$490.00
R/R EXISTING SIDEWALK ON THE SOUTH SIDE OF THE PROPERTY FROM THE CITY WALK TO THE ALLEY. R/R PATIO BEHIND THE HOUSE (SAME SIZE). INSTALL A 12' W X 14' L X 12' H ROOFED OVER PATIO ON THE EAST SIDE OF THE GARAGE. INSTALL A 4.5' W X 32' L X 12' H ROOFED OVER						

Report Of Building/Improvement Permits Issued By The City Of Berwyn

Thursday, July 1, 2021

Between: 6/1/2021 And 6/30/2021

Name and Address	P.I.N. #	Census Class	Permit Issued	Permit #	Cost Of Improvements	Cost Of Permit
AnnMarie R. Quetzacoatl 3632 S. Wesley Avenue	16-31-401-052-0000	R	6/24/2021 Impr-L	90994-0	\$1,800.00	\$140.00
CONCRETE RETAINING WALL TO AVOID FENCE FROM FALLING UNDER FENCE. REMOVING AND REPLACING WALKWAY FROM REAR OF HOUSE TO THE ALLEY ON THE NORTH SIDE.						
425 Juliana Garcia	1833 S. Euclid Avenue	16-19-409-015-0000	R	6/24/2021 Impr-L	90995-0	\$5,000.00 \$235.00
REPLACE BACK WOODEN STAIRS W/ CONCRETE, PATIO, SIDEWALKS, GUTTERS. R/R FRONT CANOPY. CONCRETE MUST PITCH TOWARDS OWN PROPERTY NOT NEIGHBOR'S OR CITY.						
426 Fernando Munoz	1306 S. Scoville Avenue	16-19-212-026-0000	R	6/24/2021 Impr-L	90996-0	\$10,000.00 \$260.00
INSTALL A ROOFED OVER PATIO WITH STEEL ON THE BACK OF THE HOUSE - 23'W X 19' L X 12' H.						
427 Maria V. Garcia	2318 S. Ridgeland Avenue	16-30-215-025-0000	R	6/24/2021 Impr-L	90997-0	\$2,500.00 \$130.00
REPAIR ROOF. REPLACE MISSING SHINGLES AND UNEVEN SHINGLES AS NEEDED. SPOT TUCKPOINT AS NEEDED. CAP CHIMNEY.						
428 Reidy / Kallas	1225 S. Scoville Avenue	16-19-205-016-0000	R	6/24/2021 Impr-L	90998-0	\$4,600.00 \$185.00
R/R REAR PORCH AND STAIRS - REBUILDING ON EXISTING STAIR WALL FOUNDATION.						
429 Cellia Castillo	3715 S. Oak Park Avenue	16-31-415-007-0000	R	6/24/2021 Roof-L	90999-0	\$5,124.00 \$140.00
TEAR OFF AND RESHINGLE ROOF ON THE HOUSE, SYNTHETIC UNDERLAYMENT OVER ROOF DECKING, ICE AND WATER SHIELD.						
430 WOMOB Fresenius Berwyn, LL	2601 S. Harlem Avenue	16-30-327-017-0000	C	6/24/2021 Impr-L	91000-0	\$10,702.30 \$225.00
POWER WASH BUILDING, REPAINT BUILDING OUTSIDE, REPAIR AND SEAL PARKING LOT, REPAIR OUTSIDE DOORS, REPAIR GAS LINES, REPLACE PARKING LOT LIGHT BULBS, REPAIR BUILDING ENTRANCE, INSTALL 2 WINDOWS IN THE 2ND FLOOR AND PAINT 2ND FLOOR STORAGE ROOM.						
431 Abraham Pulido	1608 S. Scoville Avenue	16-19-404-023-0000	R	6/24/2021 Impr-L	91001-0	\$5,000.00 \$135.00
NEW PARKING SLAB 23X18. REMOVE AND REPLACE EXISTING GARAGE APRON 13X4						
432						

Report Of Building/Improvement Permits Issued By The City Of Berwyn

Thursday, July 1, 2021

Between: 6/1/2021 And 6/30/2021

Name and Address	P.I.N. #	Census Class	Permit Issued	Permit #	Cost Of Improvements	Cost Of Permit
David Reyes Salvador 6747 W. Riverside Drive	16-30-200-026-0000	R	6/25/2021 Bldg-B	9780-0	\$50,000.00	\$1,560.00
433						
Gustavo & Elizabeth Chavez 1638 S. Elmwood Avenue	16-19-406-017-0000	R	6/25/2021 Bldg-B	9781-0	\$60,000.00	\$1,730.00
434						
Esthela Olivera 3626 S. Euclid Avenue	16-31-400-041-0000	R	6/25/2021 Impr-L	90789-1	\$4,500.00	\$85.00
435						
Martha Hernandez 3016 S. Clarence Avenue	16-30-417-023-0000	R	6/25/2021 Roof-L	91002-0	\$7,800.00	\$170.00
436						
Marquita Courts 1347 S. East Avenue	16-19-212-058-0000	R	6/25/2021 Impr-L	91003-0	\$2,000.00	\$90.00
437						
Lyn Webb 3619 S. Wenonah Avenue	16-31-311-006-0000	R	6/25/2021 Elec-L	91004-0	\$2,550.00	\$105.00
438						
Patricia Gutierrez 2837 S. Cuyler Avenue	16-29-317-016-0000	R	6/25/2021 Impr-L	91005-0	\$4,500.00	\$160.00
439						
Juan Julian Hernandez & Irene 2231 S. Grove Avenue	16-30-104-017-0000	R	6/25/2021 Fence-L	91006-0	\$3,500.00	\$135.00
440						

Report Of Building/Improvement Permits Issued By The City Of Berwyn

Thursday, July 1, 2021

Between: 6/1/2021 And 6/30/2021

Name and Address	P.I.N. #	Census Class	Permit Issued	Permit #	Cost Of Improvements	Cost Of Permit
441 Elton Cruz & Maria Cruz Rodrig 1219 S. Oak Park Avenue	16-19-200-013-0000	R	6/25/2021 Fence-L	91007-0	\$750.00	\$135.00
			INSTALLING FENCE FROM FRONT OF HANDRAIL TO EXISTING FENCE ON THE NORTH SIDE. WILL ALSO INSTALL GATE- 5FT. JULIE DIG# ATTACHED. INSTALLING CHICKEN MESH ALONG THE HANDRAIL.			
442 L. Swartzel 7042 W. Pershing Road	16-31-326-040-0000	R	6/25/2021 Roof-L	91008-0	\$13,500.00	\$310.00
			T/O & RE-ROOF HOUSE & GARAGE SHINGLE ROOF TO CODE. REMOVE POWER VENT FROM HOUSE TO SOURCE. ICE AND WATER SHIELD TO CODE.			
443 Matt Construction Group Inc 6448 W. 28th Street	16-30-413-017-0000	R	6/25/2021 Impr-L	91009-0	\$0.00	\$40.00
			DEMO INTERIOR OF PROPERTY TO STUDS. NOTHING STRUCTURAL. DUMPSTER ON STREET. DUMPSTERS/PODS REQUIRE A FLASHING BARRICADE ON THE SIDE OF INCOMMMING TRAFFIC.			
444 ARACELI ESTRADA & LLECE 3622 S. Maple Avenue	16-31-308-032-0000	R	6/25/2021 Impr-L	91010-0	\$0.00	\$50.00
			PRELIMINARY PLUMBING INSPECTION TO DETERMINE WHAT NEEDS TO BE BROUGHT UP TO CODE.			
445 Jeff Schwarte 1339 S. Ridgeland Avenue	16-20-107-014-0000	R	6/25/2021 Plum-L	91011-0	\$11,400.00	\$1,740.00
			INCREASE WATER SERVICE FROM 1" FROM CITY MAIN TO B-BOX.			
446 David Parra 2813 S. Cuyler Avenue	16-29-317-006-0000		6/25/2021 Impr-L	91012-0	\$1,500.00	\$105.00
			INTERIOR DEMO OF PROPERTY TO THE STUDS. DEMO KITCHEN, BATHROOM AND WALLS. A PRELIMINARY STRUCTURAL INSPECTION OF A WALL THE OWNER WANT TO DEMO IN THE KITCHEN AND OF THE STAIRCASE THE OWNER WANTS TO RELOCATE.			
447 Matt R. Mischnick 1307 S. Home Avenue	16-19-112-004-0000	R	6/25/2021 Impr-L	91013-0	\$1,000.00	\$190.00
			COMPLIANCE VIOLATION - ALL ELECTRIC IN HOUSE AND GARAGE MUST BE BROUGHT TO CODE, COVER 2 BLANK SPACES IN THE BREAKER BOX. EACH BEDROOM MUST HAVE AN EGRESS WINDOWS INSTALLED CODE. WORKING SMOKE ALARMS REQUIRED ON BOTH LEVELS, FURNACE ROOM AND STAIRWELLS, W			
448 Victor M. Ramirez 1826 S. Clinton Avenue	16-19-312-031-0000	R	6/25/2021 Dump-L	91014-0	\$0.00	\$50.00
			DUMPSTER ON STREET. DUMPSTERS/PODS REQUIRE A FLASHING BARRICADE ON THE SIDE OF INCOMMMING TRAFFIC.			

Report Of Building/Improvement Permits Issued By The City Of Berwyn

Thursday, July 1, 2021

Between: 6/1/2021 And 6/30/2021

Name and Address	P.I.N. #	Census Class	Permit Issued	Permit #	Cost Of Improvements	Cost Of Permit
449 Macarena Corral-Quintero 1315 S. Ridgeland Avenue	16-20-107-005-0000	R	6/28/2021 Plum-L	54588-1	\$0.00	\$50.00
450 Frank Diaz 1330 S. Scoville Avenue	16-19-212-036-0000	R	6/28/2021 Impr-L	76789-3	\$0.00	\$100.00
451 James & Jacqueline Ramos 2419 S. Clarence Avenue	16-30-219-006-0000	R	6/28/2021 Roof-L	91015-0	\$2,400.00	\$125.00
452 Rafael Ruiz, Jr. 3515 S. Elmwood Avenue	16-31-409-046-0000	R	6/28/2021 HVAC-L	91016-0	\$6,500.00	\$190.00
453 R & B Nosbisch 2936 S. Oak Park Avenue	16-30-319-029-0000	R	6/28/2021 Impr-L	91017-0	\$2,350.00	\$0.00
454 Joseph & Virginia Colosimo 3415 S. Wesley Avenue	16-31-232-006-0000	R	6/28/2021 Impr-L	91018-0	\$3,250.00	\$145.00
455 Matthew R Colony & Kristin M. 1938 S. Maple Avenue	16-19-316-033-0000	R	6/28/2021 Impr-L	91019-0	\$5,034.00	\$175.00
456 Patrick & Eileen Cauglin 3208 S. Wenonah Avenue	16-31-110-018-0000	R	6/28/2021 Roof-L	91020-0	\$7,900.00	\$170.00
457 Joseph P. Karnik and Sheryl L. 7107 W. 34th Street	16-31-121-020-0000	R	6/28/2021 Roof-L	91021-0	\$4,100.00	\$40.00
458 Gabriel & Lisa M. Callozo 1915 S. Home Avenue	16-19-320-005-0000	R	6/28/2021 Dump-L	91022-0	\$0.00	\$50.00

Report Of Building/Improvement Permits Issued By The City Of Berwyn

Thursday, July 1, 2021

Between: 6/1/2021 And 6/30/2021

Name and Address	P.I.N. #	Census Class	Permit Issued	Permit #	Cost Of Improvements	Cost Of Permit
459 Natali Gonzales-Nazario 6433 W. 34th Street	16-31-228-023-0000	R	6/28/2021 Impr-L	91023-0	\$1,000.00	\$105.00
DEMO PARTIRION WALLS IN BASEMENT (PER APPROVED INSP), REPLACE FASCIA AND SOFFIT, INSTALLING NEW EGRESS WINDOW IN THE ATTIC NORTH ELEVATION.						
460 Noel & Daisy Cruz 1407 S. Maple Avenue	16-19-117-003-0000	R	6/28/2021 Impr-L	91024-0	\$9,926.00	\$210.00
R/R NINE (9) WINDOWS AT PROPERTY. BEDROOM #1 ONE (1). BEDROOM #2 ONE (1). BRING WINDOWS TO EGRESS CODE WHERE NEEDED.						
461 Eduardo Chavez 3744 S. Oak Park Avenue	16-31-323-036-0000	R	6/28/2021 Roof-L	91025-0	\$9,673.00	\$200.00
TEAR OFF AND RE-ROOF ON THE HOUSE, ICE AND WATER SHIELD, REPLACE WOOD AS NEEDED, FLET PAPER, NEW VENTS						
462 Joyce L. Colton & Louis M. We 1645 S. Wenonah Avenue	16-19-303-020-0000	R	6/28/2021 Impr-L	91026-0	\$25,025.00	\$845.00
KITCHEN REMODEL WITH LIGHTING AND ELECTRICAL MODIFICATIONS. INSTALLING KITCHEN HOOD SYSTEM.						
463 Christopher A. Camacho & Dia 1434 S. Wenonah Avenue	16-19-118-034-0000	R	6/28/2021 Impr-L	91027-0	\$1,000.00	\$90.00
ATF INSTALL OF PAVER PATIO 18' X 30' - ALL PAVERS MUST PITCH TO OWN PROPERTY - ALL REMAINING LAND MUST BE GRASS.						
464 John Druska 1643 S. Wisconsin Avenue	16-19-302-021-0000	R	6/28/2021 Impr-L	91028-0	\$2,350.00	\$130.00
DEMO CHIMNEY DOWN TO ROOF FLASHING. REBUILD CHIMNEY BACK TO ORIGINAL HEIGHT. INSTALL AND SEAL A NEW CHIMNEY CAP.						
465 Sam Q Tomasello 2319 S. Scoville Avenue	16-30-213-006-0000	R	6/29/2021 HVAC-L	90461-1	\$0.00	\$65.00
HVAC FINAL RE-INSPECTION-----INSTALL MITSUBISHI SYSTEM. SPLIT HEATING & COOLING SYSTEM. SUPPLEMENT HEATING.						
466 Hugo Bustos 1345 S. Grove Avenue	16-19-115-023-0000	R	6/29/2021 Impr-L	91029-0	\$4,000.00	\$70.00
REPLACING SIDING ON THE GARAGE. TEAR OFF AND REROOF GARAGE ROOF.						
467 Erika Andrade Lazaro 1227 S. Kenilworth Avenue	16-19-106-018-0000		6/29/2021 Impr-L	91030-0	\$0.00	\$0.00
DUMPSTER ON STREET. DUMPSTERS/PODS REQUIRE A FLASHING BARRICADE ON THE SIDE OF INCOMMING TRAFFIC.						
468 Alicia Silva Perez 3311 S. Wesley Avenue	16-31-223-006-0000		6/29/2021 Dump-L	91031-0	\$0.00	\$0.00
DUMPSTER ON STREET. DUMPSTERS/PODS REQUIRE A FLASHING BARRICADE ON THE SIDE OF INCOMMING TRAFFIC.						

Report Of Building/Improvement Permits Issued By The City Of Berwyn

Thursday, July 1, 2021

Between: 6/1/2021 And 6/30/2021

Name and Address	P.I.N. #	Census Class	Permit Issued	Permit #	Cost Of Improvements	Cost Of Permit
469 Walter Boiko 3204 S. Cuyler Avenue	16-32-111-056-0000	R	6/29/2021 HVAC-L	91032-0	\$6,420.00	\$190.00
470 Jose Alvarez & Maria D. Alvare 1424 S. Wenonah Avenue	16-19-118-030-0000	R	6/29/2021 Impr-L	91033-0	\$11,013.00	\$240.00
471 Petar Jovanovic 3140 S. Harvey Avenue	16-32-108-013-0000	R	6/29/2021 Plum-L	91034-0	\$0.00	\$50.00
472 Eloy Carrera 1445 S. East Avenue	16-19-220-019-0000	R	6/29/2021 POD-L	91035-0	\$0.00	\$50.00
473 Kyle & Robin Gallagher 1228 S. Oak Park Avenue	16-19-107-030-0000	R	6/29/2021 Impr-L	91036-0	\$1,150.00	\$115.00
474 Manuel & Maria Del Rio 1436 S. Grove Avenue	16-19-122-031-0000	R	6/29/2021 Fence-L	91037-0	\$1,100.00	\$135.00
475 Chicago Title and Trust Compa 1812 S. Euclid Avenue	16-19-408-026-0000	R	6/29/2021 Impr-L	91038-0	\$840.00	\$40.00
476 Stephanie M. Cabrera Ramirez 1519 S. Euclid Avenue	16-19-225-008-0000	R	6/29/2021 Dump-L	91039-0	\$0.00	\$0.00
477 Maureen Cavanaugh 3646 S. Clarence Avenue	16-31-410-014-0000	R	6/29/2021 Impr-L	91040-0	\$0.00	\$0.00
478 Jacqueline Pereda 3648 S. Clarence Avenue	16-31-410-015-0000	R	6/29/2021 Impr-L	91041-0	\$0.00	\$0.00

Report Of Building/Improvement Permits Issued By The City Of Berwyn

Thursday, July 1, 2021

Between: 6/1/2021 And 6/30/2021

Name and Address	P.I.N. #	Census Class	Permit Issued	Permit #	Cost Of Improvements	Cost Of Permit
Jesus & Sylvia Casas 6852 W. Riverside Drive 479	16-30-111-003-0000	R	6/29/2021 Impr-L	91042-0	\$6,500.00	\$165.00
Gabriel Silva 3832 S. Cuyler Avenue	16-32-324-039-0000	R	6/29/2021 Fence-L	91043-0	\$2,500.00	\$135.00
Ramon Leon & Isedora Alejo 1217 S. Oak Park Avenue 480	16-19-200-052-0000	R	6/29/2021 Fence-L	91045-0	\$1,500.00	\$135.00
Jose C. Benitez 3305 S. Clinton Avenue 481	16-31-125-042-0000	R	6/29/2021 Impr-L	91047-0	\$200.00	\$0.00
Dr. Housing Painting Corp 1519 S. East Avenue 482	16-19-228-009-0000	R	6/29/2021 Impr-L	91048-0	\$6,500.00	\$150.00
Angel Esparza 2523 S. Elmwood Avenue 483	16-30-231-010-0000	R	6/29/2021 Impr-L	91049-0	\$6,000.00	\$200.00
Rafael Villegas 2242 S. Scoville Avenue 484	16-30-204-039-0000	R	6/29/2021 Impr-L	91050-0	\$2,000.00	\$90.00
Abdon & Yolanda Medina 1511 S. Home Avenue 485	16-19-128-005-0000	R	6/29/2021 Roof-L	91051-0	\$10,000.00	\$200.00
486						

Report Of Building/Improvement Permits Issued By The City Of Berwyn

Thursday, July 1, 2021

Between: 6/1/2021 And 6/30/2021

Name and Address	P.I.N. #	Census Class	Permit Issued	Permit #	Cost Of Improvements	Cost Of Permit
Lawrence R. Hosty & Nancy J. 1342 S. Cuyler Avenue 487	16-20-107-034-0000	R	6/29/2021 Impr-L	91052-0	\$450.00	\$0.00
ALBERTO VILLEGAS & ANAC 3815 S. Wenonah Avenue 488	16-31-327-005-0000	R	6/29/2021 Elec-L	91053-0	\$3,500.00	\$120.00
Jessica Patrocoa Davila 1434 S. Grove Avenue 489	16-19-122-030-0000	R	6/29/2021 Fence-L	91054-0		\$0.00
Adam Borzecki 3843 S. Wesley Avenue 490	16-31-422-025-0000	R	6/30/2021 Bldg-B	9111-1	\$0.00	\$50.00
R. Pavone & D. Vela 2843 S. Home Avenue 491	16-30-312-067-0000	R	6/30/2021 Gar-B	9666-2	\$0.00	\$100.00
Edward & Myrna Curra 3121 S. Wesley Avenue 492	16-31-202-008-0000	R	6/30/2021 Gar-B	9782-0	\$35,801.00	\$40.00
Erika Romero & Jorge Gonzale 3341 S. Harvey Avenue 493	16-32-123-031-0000	R	6/30/2021 Gar-B	9783-0	\$32,300.00	\$350.00
Raymundo & Rosaura Razo 3825 S. Oak Park Avenue 494	16-31-420-010-0000	R	6/30/2021 Bldg-B	9784-0	\$8,200.00	\$375.00
Martin S. Martinez & Nancy Ma 2844 S. Highland Avenue 495	16-29-317-038-0000	R	6/30/2021 Bldg-B	9785-0	\$2,000.00	\$765.00

Report Of Building/Improvement Permits Issued By The City Of Berwyn

Thursday, July 1, 2021

Between: 6/1/2021 And 6/30/2021

Name and Address	P.I.N. #	Census Class	Permit Issued	Permit #	Cost Of Improvements	Cost Of Permit
496 Martin & Irma Marquez 2518 S. Gunderson Avenue	16-30-229-019-0000	R	6/30/2021 Impr-L	91044-0	\$3,400.00	\$220.00
REMOVING EXISTING WALKWAY ON THE SOUTH SIDE AND REPLACE TO GO NEXT TO THE HOUSE. R/R FENCE ON THE NORTH SIDE FROM REAR OF HOUSE TO THE END OF GARAGE 5FT+1FT OPEN LATTICE. JULIE DIG# ATTACHED. REMOVIGN AND REPLACING FRONT APPROACH LEADING TO FRONT STAIRS.						
497 Linda S. Adami Trust 3617 S. Wisconsin Avenue	16-31-310-005-0000	R	6/30/2021 Impr-L	91055-0	\$12,100.00	\$140.00
CHIMNEY FOR SPOT GRIND/SPOT TUCKPOINT/SPOT REBUILD. REBUILD STAIRCASE SIDE WALL. REPLACE EXTERIOR LINTEL ABOVE 2 WINDOWS. IF GRINDING MUST TENT OR TARP AREA. WET GRINDING IS ALSO ALLOWED.						
498 Fey Family Trust 7005 W. Ogden Avenue	16-31-311-022-0000	C/R	6/30/2021 Impr-L	91056-0	\$3,000.00	\$40.00
TUCKPOINTING AS NEEDED.						
499 BERWYN DEVELOPMENT PR 1329 S. Clinton Avenue	16-19-113-012-0000	R	6/30/2021 Impr-L	91057-0	\$0.00	\$50.00
PRELIMINARY ELECTRICAL & PLUMBING TO SEE WHAT IS NOT TO CODE--WHOLE HOUSE						
500 Jasmine Guel & Vince Soto 3733 S. Home Avenue	16-31-320-014-0000	R	6/30/2021 Impr-L	91058-0	\$5,000.00	\$135.00
TEAR OFF EXISTING SIDING, WRAP WITH MOISTURE BARRIER, INSTALL NEW VINYL SIDING ON GARAGE AND FRONT PORCH.						
501 RDK Ventures LLC 6400 W. Ogden Avenue	16-31-407-031-0000	C	6/30/2021 Impr-L	91059-0	\$14,000.00	\$530.00
R/R HOT DOG GRILL, DISPLAY CABINETS AND EQUIPMENT FOR FRESH BAKED COOKIES & PRETZELS, UPGRADE ELECTRIC FOR NEW EQUIPMENT.						
502 Jose Arroyo & Connie Michelle 3110 S. Grove Avenue	16-31-106-022-0000	R	6/30/2021 HVAC-L	91060-0	\$5,015.00	\$140.00
A/C REPLACEMENT 13 SEER 3 TON						
503 Reidy / Kallas 1225 S. Scoville Avenue	16-19-205-016-0000	R	6/30/2021 HVAC-L	91061-0	\$4,400.00	\$140.00
A/C REPL 13 SEER 3 TON 3FT FROM PROPERTY LINE.						
504 Ruben Soto 3636 S. Wesley Avenue	16-31-401-054-0000	R	6/30/2021 HVAC-L	91062-0	\$21,312.00	\$280.00
R/R TWO (2) FURNACE & TWO (2) AC. A/C CONDENSERS MUST BE LOCATED BEHIND THE HOUSE 3' FROM PROPERTY LOT LINE AND ELECTRICAL METER.						
505 Francisca N Almeida Valdivia 6703 W. 16th Street	16-19-225-048-0000	R	6/30/2021 Impr-L	91063-0	\$1,700.00	\$40.00
R/R GARAGE ROOF TO CODE. ICE AND WATER SHIELD TO CODE.						

Report Of Building/Improvement Permits Issued By The City Of Berwyn

Thursday, July 1, 2021

Between: 6/1/2021 And 6/30/2021

Name and Address	P.I.N. #	Census Class	Permit Issued	Permit #	Cost Of Improvements	Cost Of Permit
506 Yan Cui 1943 S. Scoville Avenue	16-19-421-014-0000	R	6/30/2021 Impr-L	91064-0	\$10,200.00	\$0.00
5 UNIT: UPGRADE ELECTRICAL SERVICE TO CODE. COMPLIANCE VIOLATIONS. REPLACE EXPOSED WATER PIPE WITH COPPER/ CHANGE KITCHEN CABINETS. REMODEL BATHROOMS. PAINTING ALL UNITS.						
507 Lawrence Boyle 3244 S. Wenonah Avenue	16-31-110-032-0000	R	6/30/2021 Roof-L	91065-0	\$4,450.00	\$125.00
T/O & RE-ROOF HOUSE SHINGLE ROOF TO CODE. ICE AND WATER SHIELD TO CODE. NO POWER VENTS.						
508 Victor & Juan Castellanos 2406 S. Wesley Avenue	16-30-217-019-0000	R	6/30/2021 Plum-L	91066-0	\$3,200.00	\$120.00
SEWER REPAIR PRIVATE PROPERTY - PROVIDE VIDEO TO BUILDING DEPARTMENT ONCE SEWER REPAIR IS COMPLETE						
509 Ines & Jose Rayas 2345 S. Home Avenue	16-30-105-018-0000	R	6/30/2021 Impr-L	91067-0	\$4,000.00	\$170.00
INSTALL SPRINKLER ON PRIVATE PROPERTY.						
510 Guy G. Hawkins & Melody L H 2509 S. Gunderson Avenue	16-30-230-004-0000	R	6/30/2021 Impr-L	91068-0	\$1,595.00	\$85.00
REPLACING 40 GALLON WATER HEATER						
511 Eduardo Del LA Torre & Dolore 7008 W. Cermak Road	16-19-327-030-0000	C/R	6/30/2021 Impr-L	91069-0	\$3,000.00	\$605.00
COMPIANCE: INSTALL EXHAUST FAN IN 1ST FLR POWDER ROOM. REPAIR OR REPLACE GFCI IN 1ST FLR POWDER ROOM. CLEAN AND CHECK RPZ VALVE. ENCLOSE ELECTRICAL JUNCTION BOX IN 1ST FLR REAR STORAGE ROOM (CEILING AREA). REPAIR PLUMBING LEAKS ON 1ST FLR CEILING AREAS. IN						
512 PAUL ESCAMILLA 6540 W. 27th Place	16-30-411-004-0000	R	6/30/2021 Impr-L	91070-0	\$3,500.00	\$595.00
REMODEL THE KITCHEN, R/R CABINETS, COUNTERTOP AND SINK. INSTALL A KITCHEN HOOD SYSTEM. REMOVE KITCHEN DMV AND WASTE TO OPPOSITE SIDE, WEST WALL. R/R DRYWALL IN KITCHEN. MOVE LAUNDRY ROOM TO OPPOSITE OF BASEMENT.						
513 Jessyca Monsalve 1936 S. Kenilworth Avenue	16-19-321-029-0000	R	6/30/2021 Impr-L	91072-0	\$350.00	\$190.00
COMPLIANCE- BASEMENT BATHROOM MUST HAVE AN ERESS WINDOW INSTALLED TO CODE, BASEMENT BATHROOM MUST HAVE PERMANENT CONTROLLABLE HEAT SOURCE TO CODE, OPEN BULB LIGHTS IN BASEMENT APARTMENT CLOSET AND BASEMENT FURNACE ROOM MUST BE FULLY ENCLOSED BULB FIXTURE,						

Report Of Building/Improvement Permits Issued By The City Of Berwyn

Thursday, July 1, 2021

Between: 6/1/2021 And 6/30/2021

Name and Address	P.I.N. #	Census Class	Permit Issued	Permit #	Cost Of Improvements	Cost Of Permit
514 Jessyca Monsalve 1936 S. Kenilworth Avenue	16-19-321-029-0000	R	6/30/2021 Impr-L	91073-0	\$3,500.00	\$645.00
JOB STOP- TOP FLOOR REAR UNTI. REMOVIGN AND RPELACING CABINETS, REPLACING TILE IN THE BATHROOM, ADDING STAIN FLOOR, REPLACING DRYWALL IN BATHROOM, REPLACING BACKSPLASH.						
515 Ramon Valladarez 1544 S. Grove Avenue	16-19-130-045-0000	R	6/30/2021 Plum-L	91074-0	\$5,900.00	\$1,650.00
INCREASE WATER SERVICE TO 1" - FROM THE CITY MAIN TO THE B-BOX AND THEN FROM THE B-BOX TO THE HOUSE. PARKWAY MUST BE RE-SODDED.						
516 Yuliana Avila 2334 S. Highland Avenue	16-29-109-036-0000	R	6/30/2021 Dump-L	91075-0	\$0.00	\$50.00
DUMPSTER TO BE ON THE STREET. DUMPSTERS/PODS REQUIRE A FLASHING BARRICADE ON THE SIDE OF INCOMMING TRAFFIC.						
517 Onofrio Agozzino 1828 S. Euclid Avenue	16-19-408-032-0000	R	6/30/2021 Impr-L	91076-0	\$6,000.00	\$175.00
REPLACE DAMAGED BRICKS FROM WEST SIDE OF THE HOUSE AROUND 3 FEET ON THE TOP PARAPET WALL, GRIND AND TUCKPOINT FRONT FACIAL BRICK PARAPET WALL, GRIND AND TUCKPOINT FRONT ENTRANCE BRICK WALL, GRIND AND TUCKPOINT CHIMNEY ON THE TOP.						
518 Martin & Marina Mcnicholas 2629 S. Wesley Avenue	16-30-402-017-0000	R	6/30/2021 Impr-L	91077-0	\$150.00	\$50.00
COMPLIANCE VIOLATIONS - SEVERAL WINDOWS ARE MISSING HANDLES, REPLACE ANDY MISSING WINDOWS HANDLES AS NEEDED, UPPER SECTIONS OF STAIRWAY LEADING TO THE BASEMENT MUST HAVE HANDRAILS INSTALLED TO CODE, ATF FOR ADDITIONAL ELECTRICAL WORK BEING INSTALLED IN TH						
519 Lamar & Aiza Burgos 3709 S. Wenonah Avenue	16-31-319-004-0000	R	6/30/2021 Impr-L	91078-0	\$350.00	\$50.00
ATF BATHROOM REMODEL- REPLACED SINK AND VANITY.						
520 Jay & Carol Hallberg 3814 S. Wisconsin Avenue	16-31-325-018-0000	R	6/30/2021 Impr-L	91079-0	\$0.00	\$125.00
INSTALLING ABOVE GROUND POOL PER PRE APPROVED INSP, WILL ALSO RUN POWER AND GFI PROTECTED.						

520 Building and Local Improvement Permits Issued During Period

Totals \$4,196,759.29 \$119,710.00

Robert J. Lovero
Mayor



**Collections and
Licensing**

6700 West 26th Street Berwyn, Illinois 60402-0701 Telephone: (708) 788-2660 Fax: (708) 749-8910
www.berwyn-il.gov

K-5

July 8, 2021

Honorable Mayor Robert J. Lovero
And Members of the City Council
Berwyn City Hall
Berwyn, Illinois 60402

Dear Mayor and Council Members:

Attached please find a list of business licenses, which were issued, by the Collection and Licensing Department for the month of May - June 2021. Included are storefronts & phone use only businesses. I am also providing a list of businesses that have applied for a license with a current status of Application Review/Pending as well as businesses waiting for inspections with a status of Inspections Pending.

Respectfully,

Jeannette Rendon

Jeannette Rendon
For Benjamin Daish
Finance Director

Inspections Pending

Business Name	Address	Last Update	Phone	ID #
<i>All Meal Prep</i> 6908 W. Windsor Avenue Berwyn IL 60402		5/29/2019	(312) 313-2011	18637
<i>Berwyn Auto</i> 6317 W. Ogden Avenue Berwyn IL 60402		9/12/2018	(708) 788-3300	18083
<i>Cricket Wireless</i> 6946 W. Cermak Road Berwyn IL 60402		12/2/2019	(708) 317-4547	19004
<i>Gregory Rodriguez d.b.a</i> 6219 W. 26 th Street Berwyn IL 60402	<i>The Barber's Shop</i>	5/18/2020	(224) 392-7257	19210
<i>Little Fenix Restaurant</i> 3248 - 50 Grove Avenue S. Berwyn IL 60402		6/16/2021		19851
<i>Pennan Properties</i> 2721 S. Ridgeland Avenue Berwyn IL 60402		7/19/2019	(708) 406-7550	18700
<i>Turano Fleet Maintenance Facility</i> 1431 S. Harlem Avenue Berwyn IL 60402		5/25/2016	(708) 788-9220	16750
Total Businesses				7

BERWYN BUSINESSES - LICENSED IN MAY - JUNE 2021 (STOREFRONTS)

<u>Address</u>		<u>Business Name</u>	<u>Owner</u>	<u>Phone #</u>
6910 W.	Cermak Road	Berwyn Custom Tattoo Company	Omar Bates	956-7689
6901 W.	Cermak Road	Marissa Gutierrez d.b.a. Spa Tozi	Marissa Gutierrez	870-1218
2137 S.	Oak Park Avenue	Pro Makeup Art	Ashley Roldan	844-4059
6405 W.	34 th Street	Alex Mendoza Law, P.C.	Alex Mendoza	508-6010
2137 S.	Oak Park Avenue	Venice Beauty Bar	Michelle Martinez	998-2238

Robert J. Lovero
Mayor



Collections and
Licensing

6700 West 26th Street Berwyn, Illinois 60402-0701 Telephone: (708) 788-2660 Fax: (708) 749-8910
www.berwyn-il.gov

K-6

July 8, 2021

Honorable Mayor Robert J. Lovero
And Members of the City Council
Berwyn City Hall
Berwyn, Illinois 60402

Dear Mayor and Council Members:

The Local Ordinance Fines, which were collected by the City of Berwyn (Building/Neighborhood Affairs) and recorded by the Collection department in May - June 2021, amounted to \$37,293.00. Report copies are in their respective files and balancing copies are referred to the Finance Department on a daily basis or as received and recorded.

I, the undersigned, hereby acknowledge the sum of \$37,293.00 as herein above mentioned.

Jeannette Rendon *JR*
For Benjamin Daish
Finance Director

<u>ACCOUNT NUMBER</u>	<u>AMOUNT</u>
25455	\$37,293.00
Through 40880	
	amount totaled due to
	number of transactions
TOTAL	\$37,293.00

Robert J. Lovero
Mayor



**Collections and
Licensing**

6700 West 26th Street Berwyn, Illinois 60402-0701 Telephone: (708) 788-2660 Fax: (708) 749-8910
www.berwyn-il.gov

K-7

July 8, 2021

Honorable Mayor Robert J. Lovero
And Members of the City Council
Berwyn City Hall
Berwyn, Illinois 60402

Dear Mayor and Council Members:

The Compliance Tickets, which were collected by the Records Division of the Police Department and recorded by the Collections Department in May - June 2021 amounted to \$8,510.00

A report copy for each month is attached and ticket copies are on file in the Records Division of the Berwyn Police Department.

I, the undersigned, hereby acknowledge
The total sum of \$8,510.00 as herein above
mentioned.

Jeannette Rendon 
For Benjamin Daish
Finance Director

<u>ACCOUNT NUNMBER</u>	<u>AMOUNT</u>
26046	\$8,510.00
Through 40481	
	Amount totaled due to
	Number of transaction
TOTAL	\$8,510.00

Robert J. Lovero
Mayor



Collections and
Licensing

6700 West 26th Street Berwyn, Illinois 60402-0701 Telephone: (708) 788-2660 Fax: (708) 749-8910
www.berwyn-il.gov

July 8, 2021

K-8

Honorable Mayor Robert J. Lovero
And Members of the City Council
Berwyn City Hall
Berwyn, Illinois 60402

Dear Mayor and Council Members:

The adjudication fines collected in accordance with Local Ordinance Tickets, by the Police Department and recorded by the Collection department during May - June 2021 amounted to \$3,550.00

Ticket copies are on file with the Parking Division located in the City of Berwyn's Police Department.

I, the undersigned, hereby acknowledge the total sum of \$3,550.00 as herein above mentioned.

Jeannette Rendon *JR*
For Benjamin Daish
Finance Director

<u>ACCOUNT NUNMBER</u>	<u>AMOUNT</u>
26603	\$3,550.00
Through 40481	
	Amount totaled due to
	Number of transaction
TOTAL	\$3,550.00

Robert J. Lovero
Mayor



Collections and
Licensing

6700 West 26th Street Berwyn, Illinois 60402-0701 Telephone: (708) 788-2660 Fax: (708) 749-8910
www.berwyn-il.gov

July 8, 2021

K-9

Honorable Mayor Robert J. Lovero
And Members of the City Council
Berwyn City Hall
Berwyn, Illinois 60402

Dear Mayor and Council Members:

The parking violation tickets, (P) tickets, which were collected by the parking violation fine clerk and the Collection department during May - June 2021 amounted to \$117,880.00
A copy of these ticket numbers and amounts are attached and tickets are on file in the parking fine Collector's Office.

I, the undersigned, hereby acknowledge
the total sum of \$117,880.00 as herein above
mentioned.

Jeannette Rendon 
For Benjamin Daish
Finance Director

<u>ACCOUNT NUNMBER</u>	<u>AMOUNT</u>
26046	\$117,880.00
Through 40481	
	Amount totaled due to
	Number of transaction
TOTAL	\$117,880.00

Robert J. Lovero
Mayor



**Collections and
Licensing**

6700 West 26th Street Berwyn, Illinois 60402-0701 Telephone: (708) 788-2660 Fax: (708) 749-8910
www.berwyn-il.gov

July 8, 2021

K-10

Honorable Mayor Robert J. Lovero
And Members of the City Council
Berwyn City Hall
Berwyn, Illinois 60402

Dear Mayor and Council Members:

The Seizure and Impound Fees collected by the Records Division of the Berwyn Police Department and recorded by the Collection department during May - June 2021, amounted to \$17,100.00.

The Police Department Records Division has report copies on file.

I, the undersigned, hereby acknowledge the total sum of \$17,100.00 as herein above mentioned.

Jeannette Rendon *JR*
For Benjamin Daish
Finance Director

<u>ACCOUNT NUNMBER</u>	<u>AMOUNT</u>
26046	\$17,100.00
Through 39904	
	Amount totaled due to Number of transaction
TOTAL	\$17,100.00

Robert J. Lovero
Mayor



**Collections and
Licensing**

6700 West 26th Street Berwyn, Illinois 60402-0701 Telephone: (708) 788-2660 Fax: (708) 749-8910
www.berwyn-il.gov

July 8, 2021

K-11

Honorable Mayor Robert J. Lovero
And Members of the City Council
Berwyn City Hall
Berwyn, Illinois 60402

Dear Mayor and Council Members:

The Court Fines collected by the Municipal Department, Circuit Court of Cook County, Illinois, District 4, recorded by the Collection department totaling \$7,776.11
A copy of the report is on file at the City of Berwyn Police Department.

I, the undersigned, hereby acknowledge
the total sum of \$7,776.11 as herein
above mentioned.

Jeannette Rendon 
For Benjamin Daish
Finance Director

Amount: \$7,776.11
Applied: During the month of June 2021

Mayor
Robert J. Lovero



1st Ward Alderman
James "Scott" Lennon

K-12

July 13, 2021

The Honorable Robert J. Lovero
Members of the City Council

RE: Handicap Parking Application #1351

Ladies and Gentlemen:

After careful review, I concur with the staff recommendation and respectfully submit the attached application for a **DENIAL** of a handicap **SPACE**.

<u>Address</u>	<u>Applicant Name</u>	<u>Application #</u>
3734 S. Oak Park Ave.	Joseph Zverina	1351

Thank you very much,

James "Scott" Lennon
1st Ward Alderman

JSL/sla

Enc: Handicap Application



Berwyn Police Department

6401 West 31st. Street
Berwyn, Illinois 60402
708-795-5600
Fax 708-795-5627
Emergency Call 911

Handicapped - Parking / Zone Request Form

To : Mayor Robert J. Lovero
From: Berwyn Police Department Community Service Division
Date : 3/1/2021
Officer: T. Young# 183

Applicant Name: Joseph Zverina
Address: 3734 Oak Park Ave Berwyn Il 60402
Telephone:
Nature of Disability:

Information

Doctor's Note/ Affidavit:	Yes <input checked="" type="checkbox"/> No <input type="checkbox"/>	Interviewed:	Yes <input checked="" type="checkbox"/> No <input type="checkbox"/>
Owner's Support Letter	Yes <input checked="" type="checkbox"/> No <input type="checkbox"/>	Handicapped Plate	Yes <input type="checkbox"/> No <input checked="" type="checkbox"/>
Garage:	Yes <input checked="" type="checkbox"/> No <input type="checkbox"/>	Handicapped Placard	Yes <input checked="" type="checkbox"/> No <input type="checkbox"/>
Driveway:	Yes <input type="checkbox"/> No <input checked="" type="checkbox"/>	Wheelchair:	<input type="checkbox"/>
Off Street:	Yes <input type="checkbox"/> No <input checked="" type="checkbox"/>	Walker / Cane:	<input type="checkbox"/>
On Street:	Yes <input checked="" type="checkbox"/> No <input type="checkbox"/>	Oxygen:	<input type="checkbox"/>

Meets Police Dept Requirements	Space	Yes <input type="checkbox"/> No <input checked="" type="checkbox"/>
	Zone	Yes <input checked="" type="checkbox"/> No <input type="checkbox"/>

Report # 21-01762

1ST Ward Alderman: JAMES "SCOTT" LENNON

Staff Recommendation	
Approved <input type="checkbox"/>	Denied <input checked="" type="checkbox"/>

OFFICIAL SWORN POLICE REPORT

Berwyn Police Department

6401 W 31st Street Berwyn, IL 60402 (708) 795-5600

Incident#: 21-01762

STATION COMPLAINT UCR/Offense Code 9041 (Applicant File)			INCIDENT # 21-01762		
REPORT TYPE Incident Report	RELATED CAD # C21-010281	DESCRIPTION Applicant File			
DOT #	LOCATION OF OFFENSE (HOUSE NO., STREET NAME) 3734 S OAK PARK AV Berwyn, IL 60402 (41.823867,-87.792885)				
Primary Officer YOUNG, TERRY					
HOW RECEIVED Telephone	WHEN REPORTED 02/26/2021 09:02	TIME OF OCCURRENCE 02/26/2021 09:02	STATUS CODE	STATUS DATE	

INVOLVED ENTITIES

NAME Zverina, Joseph					DOB	AGE 89
ADDRESS 3734 S OAK PARK AV Berwyn, IL 60402				FBI #	IR #	
SEX M	RACE: ETH:	HGT	WGT	HAIR	PHONE Home	
EYES	SID #	DL #	DL State		ALT PHONE Home	
CLOTHING				Handcuff Double Locked	Prints Taken	Criminal History
Employer						
UCR 9041 Applicant File, 1				TYPE Reporting Party	RELATED EVENT #	Count 0
STATUTE						

DRAFT

INVOLVED VEHICLES

VEH/PLATE #	STATE IL	TYPE Carrall/SUV	INVOLVEMENT Involved	VIN # 3GNAXKEVXLS604109
YEAR 2020	MAKE Chevrolet	MODEL Equinox	COLOR Silver/Aluminum	OWNER
COMMENTS				
Towed	Towed By		Tow Number	Impounded
				Hold

OFFICIAL SWORN POLICE REPORT

Berwyn Police Department

6401 W 31st Street Berwyn, IL 60402 (708) 795-5600

Incident#: 21-01762

STATION COMPLAINT UCR/Offense Code 9041 (Applicant File)			INCIDENT # 21-01762	
REPORT TYPE Incident Report	RELATED CAD # C21-010281	DESCRIPTION Applicant File		
DOT #	LOCATION OF OFFENSE (HOUSE NO., STREET NAME) 3734 S OAK PARK AV Berwyn, IL 60402 (41.823867,-87.792885)			
Primary Officer YOUNG, TERRY				
HOW RECEIVED Telephone	WHEN REPORTED 02/26/2021 09:02	TIME OF OCCURRENCE 02/26/2021 09:02	STATUS CODE	STATUS DATE

NARRATIVES

PRIMARY NARRATIVE

Joseph Zverina is requesting a handicap parking sign in front of his residence located at 3734 Oak Park. He drives a 2020 Silver Chevy Equinox II Berwyn VT# 3045, and has a valid Il handicap placard# DA77732. He resides in a single family home with a 2 car garage that is used for overnight vehicle storage. There are 2 handicap signs located at 3740 Oak Park, and 3741 Oak Park. There is a fire hydrant located in front of the residence. The area is mostly single family homes.

Joseph does not meet the requirements for handicap parking due to the fire hydrant by his residence, but may meet the requirement for a handicap drop off zone, would need measurement form public works.

REPORTING OFFICER YOUNG, TERRY	Unit # 183	SUPERVISOR	Unit #
-----------------------------------	---------------	------------	--------

DRAFT

Handicapped Space/Zone Police Department Site Inspection

Application # 1351

Police Department Designee C.S.O. Terry Young

Comments: Resides in a single family home with 2 car garage. 2 handicap signs located at 3740 Oak Park, and 3741 Oak Park. Fire hydrant in front of residence, may qualify for drop off zone after being measured. The area mostly single family homes.

Date: 3/1/2021

Police Report # 21-01762

Handicapped Space/Zone Public Works Site Inspection

Application # 1351

Public Works Director or Designee Dan Schiller

Comments: There is not sufficient parking for a reserved space in front of this property due to a fire hydrant. There is a 2 car garage on the property.

Meets Public Works Criteria:

Parking Space	Yes	<input type="checkbox"/>	No	<input checked="" type="checkbox"/>
Parking Zone	Yes	<input type="checkbox"/>	No	<input checked="" type="checkbox"/>

Date: 3/1/2021

Police Report # 21-01762

**Handicapped Space/Zone
Traffic Engineer Site Inspection**

Application # 1351

Traffic Engineer or Designee Nicole Campbell

Comments: Has a garage and stated that he parks in the garage.

Meets Traffic Criteria for:

Parking Space	Yes	0	No	X
Parking Zone	Yes	0	No	X

Date: 3/1/2021

Police Report # 21-01762

Rec'd by City Clerk: 3/2/2021
To Alderman: 3/2/2021
To Council: 7/13/21
Determination: DENY
Notice to Applicant:
Paid:
Sign #:

Comments:

The City of Berwyn
Mayor Robert J. Lovero



Margaret Paul
City Clerk

A Century of Progress with Pride

6700 West 26th Street Berwyn, Illinois 60402-0701 Telephone: (708) 788-2660 Fax: (708) 788-2675
www.berwyn-il.gov

Physician Form (A)

This form must be filled out in its entirety and signed by your physician.

Physician must state, by printing below, the nature of the patient's handicap

Does the patient utilize any of the following? :

Walker _____ Wheel Chair _____ Cane _____ Oxygen _____

I hereby certify that the physical conditions of the above named "Handicapped Person" constitutes him/her as a handicapped person as defined under the statutory provision Par. 1-159 (Physically Handicapped Person – Every natural person who has permanently lost the use of a leg or both legs or an arm or both arms or any combination thereof or any person who is so severely disabled as to be unable to move without the aid of crutches or a wheelchair.)

(Physician's Signature/Stamp)

2/11/2021

(Date)

MATTHEW ANDERSEN, MD

(Print Physician's Name)

6827 W. Stanley Ave. Berwyn IL

(Address and Telephone Number) 60402

Return the completed form to the City Clerk's Office at Berwyn City Hall
6700 West 26th Street, Berwyn, Illinois

The City of Berwyn
Mayor Robert J. Lovero



Margaret Paul
City Clerk

A Century of Progress with Pride

6700 West 26th Street Berwyn, Illinois 60402-0701 Telephone: (708) 788-2660 Fax: (708) 788-2675
www.berwyn-il.gov

Form B

Owner Consent For Handicap Sign

Placement/Drop-off Zone

I Joseph Zverina JR, owner/manager of the property at
3734 So. Oak Park Ave., state as follows:

1) That _____ is a tenant at the above listed property.

2) That _____ has no access to any parking on the premises.

3) That if Joseph Zverina JR is granted a handicapped sign or drop-off zone by the City of Berwyn, I have no objection to the placement of signs in front of this address.

4) I agree to notify the City of Berwyn if _____ no longer resides on the premises.

Signature/Date

Name: Joseph Zverina JR
Address: 3734 So. Oak Park Ave.
Phone#: _____



City Council Communication – Request for Block Party

K-13

To: Mayor Robert J. Lovero and Members of the Berwyn City Council

From: Residents of the 26 00 Block of Wesley (i.e. 1200 Block of Home)

Date: 8/7/2021

Re: Request for Block Party Approval

Dear Mayor Lovero and City Council:

The residents of the above listed street request approval for our Block Party to be held on:

Requested Date: 8/14, 2021 from 8:00 a.m. until 9:00 p.m.

Rain Date: 8/28, 2021 from 8:00 a.m. until 9:00 p.m.

We have also submitted the following forms with this request:

- Completed City of Berwyn Event Application, and
- A petition signed by at least 50% of the homeowners residing on our block.

I am the organizer of the Block Party. I have received and read the Berwyn Code of Ordinances regarding Block Parties ~~and Bounce Houses~~. My neighbors and I agree to abide by all the laws of the City of Berwyn and State of Illinois. In addition, we state that:

- We understand that the **use of fireworks is illegal** in Berwyn and in Illinois. We understand that our use of fireworks during our block party may result in the cancelling of our permit resulting in the ending of our party along with the possible issuance of tickets and fines.
- We also understand that Live Bands, DJ's or any amplified music must be kept at a reasonable level so as not to disturb other neighbors.
- We agree to clean up our block after the party.

As the permit holder, I understand that I am accepting responsibility for the activities conducted during the time of this permit. I also agree to notify all my neighbors of the date and time of the Block Party.

Thank you for considering our Block Party request,

Janine Beardon

Print Name

26 Wesley
Address

708-749-6452
Phone Number

janine.beardon@berwyn.il.gov
E-mail Address

PLEASE RETURN TO THE OFFICE OF THE CITY CLERK 8 WEEKS PRIOR TO YOUR REQUESTED DATE
6700 W 26th St, Berwyn, IL 60402 Phone: 708-749-6452



CITY OF BERWYN EVENT APPLICATION



Please provide information about your planned event:

Date of Event: 8/7/2021, 2021 Time: Start 8 AM End 9 PM

Allowed Event Times

Block Parties
8AM to 9PM

All Other Events
8AM to 11PM

Type: Block Party Parade Open Air Event Use of Public Way

Description of Event: _____

Location of Event: 2600 Wesley

(Please print)

Name of Applicant: Jeanine Boardon

Address: _____ Daytime Phone: _____

E-mail Address: _____ It. Phone: _____

Do you plan to use: (Please mark all that apply)

Live or Recorded Music <input type="checkbox"/>	Sound Equip. / Amplifiers <input type="checkbox"/>	Bounce Houses or Inflatables <input type="checkbox"/>
	Food Vendors <input type="checkbox"/>	Commercial Food Prep. Equipment <input type="checkbox"/>
Crafter / Vendors <input type="checkbox"/>	Alcohol Sales <input type="checkbox"/>	Portable Toilets and Sanitation <input type="checkbox"/>

Will you require any of the following City services? Yes No

* Please contact the Police Dept. for fee schedule if requesting Police Detail or Security.

Street Closure <input checked="" type="checkbox"/>	Rolling Street Closure <input type="checkbox"/>	Alley Closure <input type="checkbox"/>	Parade Route Closure <input type="checkbox"/>
Barricades <input checked="" type="checkbox"/>	*Police Detail/Security <input type="checkbox"/>	Traffic Control <input type="checkbox"/>	**Berwyn Public Library Book Reddler (Bike) <input type="checkbox"/>
**Fire Truck <input checked="" type="checkbox"/>	**McGruff <input checked="" type="checkbox"/>	**K-9 Unit <input type="checkbox"/>	**Police Explorers Unit <input type="checkbox"/>

** These City services supplied only if available on the day of the event and subject to personnel availability

City Council Approval IS REQUIRED for your event. (City Council meets the 2nd & 4th Tuesday of every month)

- Submit this application to the Clerk's Office **8 weeks** prior to the event date.
- A Certificate of Insurance is required for Parades, Outdoor Events, Use of Public Way, as well as for all food and beverage sales.
- A Food License is required from the Berwyn Public Health Department for ALL food sales.
- A City of Berwyn Temporary Liquor License is required for ALL alcoholic beverage sales.
- A route map must be submitted with this application for all parades / demonstrations.
- USE OF PUBLIC WAY: Provide a list of intersections/corner locations and all dates being requested for use of public way. Location and Date availability is subject to approval. Use of public way is limited to one group per day, one group per location, and on a First Come—First Serve basis.
- The City reserves the right to regulate, restrict and limit use of the public way at all times.



Petition – Request for Block Party

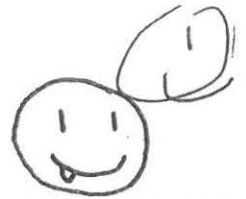

This petition must list signatures of residents who represent at least 50% of the homeowners on the block. YOU must notify ALL neighbors on the block - even those who did not sign the petition- of the block party date and time at least seven days in advance.

8 weeks prior to your Block Party date submit the completed petition along with a completed City of Berwyn Event Application and City Council Communication form to the Office of the Berwyn City Clerk so your application may be submitted to City Council for approval.

Petition for Block Party

The undersigned, being residents of the 2600 block of Wesley, hereby request the City of Berwyn to close the aforementioned block to vehicular traffic on 8/18/2021 with a rain date of 8/28/2021 from the hours of 8:00 a.m. until 9:00 p.m.

NAME:

ADDRESS:

Redacted	2625 Wesley Ave
	2629 WESLEY AVE
	2641 WESLEY AVE
	2646 Wesley Ave
	2632 Wesley Ave.
	2626 S. Wesley
	2624 Wesley. Ave 6500
	2613 Wesley Ave
	2615 Wesley Ave
	2627 Wesley Ave
	2616 Wesley Ave
	2618 Wesley Ave
	2639 Wesley Rd
	2647 Wesley
	2648 Wesley
	2642 Wesley
	2638 Wesley
	2634 Wesley
2620 Wesley	



Petition – Request for Block Party

The undersigned, being residents of the 2600 block of Wesley, hereby request the City of Berwyn to close the aforementioned block to vehicular traffic on 8/16/21 with a rain date of 8/28/21 from the hours of 8 a.m. to 9 p.m. to 9 a.m. pm

NAME: _____

ADDRESS: _____

Redacted

2610 Wesley aul
2635 WESLEY AVE.



City Council Communication – Request for Block Party

K-14

To: Mayor Robert J. Lovero and Members of the Berwyn City Council

From: Residents of the 18 00 Block of WENDONAH AVE (i.e. 1200 Block of Home)

Date: 8-14-2021

Re: Request for Block Party Approval

Dear Mayor Lovero and City Council:

The residents of the above listed street request approval for our Block Party to be held on:

Requested Date: 8/14/ 2021 from 8:00 a.m. until 9:00 p.m.

Rain Date: 8/21/ 2021 from 8:00 a.m. until 9:00 p.m.

We have also submitted the following forms with this request:

- Completed City of Berwyn Event Application, and
- A petition signed by at least 50% of the homeowners residing on our block.

I am the organizer of the Block Party. I have received and read the Berwyn Code of Ordinances regarding Block Parties ~~and Bounce Houses~~. My neighbors and I agree to abide by all the laws of the City of Berwyn and State of Illinois. In addition, we state that:

- We understand that the **use of fireworks is illegal** in Berwyn and in Illinois. We understand that our use of fireworks during our block party may result in the cancelling of our permit resulting in the ending of our party along with the possible issuance of tickets and fines.
- We also understand that Live Bands, DJ's or any amplified music must be kept at a reasonable level so as not to disturb other neighbors.
- We agree to clean up our block after the party.

As the permit holder, I understand that I am accepting responsibility for the activities conducted during the time of this permit. I also agree to notify all my neighbors of the date and time of the Block Party.

Thank you for considering our Block Party request,

Olvin Pagan - Jose Peña

Print Name

Address

1111 Berwyn IL 60402
ave Berwyn IL 60402

Phone Number

E-mail Address

PLEASE RETURN TO THE OFFICE OF THE CITY CLERK 8 WEEKS PRIOR TO YOUR REQUESTED DATE
6700 W 26th St, Berwyn, IL 60402 Phone: 708-749-6452



CITY OF BERWYN EVENT APPLICATION



Please provide information about your planned event:

Date of Event: 8-14- 2021 Time: Start 8:00AM End 9:PM

Allowed Event Times
Block Parties 8AM to 9PM
All Other Events 8AM to 11PM

Type: Block Party Parade Open Air Event Use of Public Way

Description of Event: BLOCK PARTY

Location of Event: 1800 BLOCK WENOMAH AVE

(Please print)
Name of Applicant: OLVIN PAGAN

Address: _____ Daytime Phone: _____

E-mail Address: _____ Alt. Phone: _____

Do you plan to use: (Please mark all that apply)

Live or Recorded Music <input checked="" type="checkbox"/>	Sound Equip. / Amplifiers <input checked="" type="checkbox"/>	Bounce Houses or Inflatables <input type="checkbox"/>
	Food Vendors <input type="checkbox"/>	Commercial Food Prep. Equipment <input type="checkbox"/>
Crafter / Vendors <input type="checkbox"/>	Alcohol Sales <input type="checkbox"/>	Portable Toilets and Sanitation <input type="checkbox"/>

Will you require any of the following City services? Yes No

* Please contact the Police Dept. for fee schedule if requesting Police Detail or Security.

** These City services supplied only if available on the day of the event and subject to personnel availability

Street Closure <input checked="" type="checkbox"/>	Rolling Street Closure <input type="checkbox"/>	Alley Closure <input type="checkbox"/>	Parade Route Closure <input type="checkbox"/>
Barricades <input checked="" type="checkbox"/>	*Police Detail/Security <input type="checkbox"/>	Traffic Control <input type="checkbox"/>	**Berwyn Public Library Book Peddler (Bike) <input type="checkbox"/>
**Fire Truck <input type="checkbox"/>	**McGruff <input type="checkbox"/>	**K-9 Unit <input type="checkbox"/>	**Police Explorers Unit <input type="checkbox"/>

City Council Approval IS REQUIRED for your event. (City Council meets the 2nd & 4th Tuesday of every month)

- Submit this application to the Clerk's Office **8 weeks** prior to the event date.
- A Certificate of Insurance is required for Parades, Outdoor Events, Use of Public Way, as well as for all food and beverage sales.
- A Food License is required from the Berwyn Public Health Department for ALL food sales.
- A City of Berwyn Temporary Liquor License is required for ALL alcoholic beverage sales.
- A route map must be submitted with this application for all parades / demonstrations.
- USE OF PUBLIC WAY: Provide a list of intersections/corner locations and all dates being requested for use of public way. Location and Date availability is subject to approval. Use of public way is limited to one group per day, one group per location, and on a First Come—First Serve basis.
- The City reserves the right to regulate, restrict and limit use of the public way at all times.



Petition – Request for Block Party

This petition must list signatures of residents who represent at least 50% of the homeowners on the block. YOU must notify ALL neighbors on the block - even those who did not sign the petition- of the block party date and time at least seven days in advance.

8 weeks prior to your Block Party date submit the completed petition along with a completed City of Berwyn Event Application and City Council Communication form to the Office of the Berwyn City Clerk so your application may be submitted to City Council for approval.

Petition for Block Party

The undersigned, being residents of the 1800 block of WENONAH AVE, hereby request the City of Berwyn to close the aforementioned block to vehicular traffic on 8-14-2021 with a rain date of _____ from the hours of 8:00 a.m. until 9:00 p.m.

NAME:

ADDRESS:

NAME:	ADDRESS:
Redacted	1840 Wenonah Ave
	1836 Wenonah Ave
	1841 Wenonah Ave
	1839 Wenonah Ave
	1807 Wenonah
	1802 Wenonah
	1804 Wenonah Ave
	1814 Wenonah
	1810 Wenonah Ave
	1815 Wenonah
	1801 Wenonah Ave
	1803 Wenonah
	1803 Wenonah
	1813 Wenonah
	1819 Wenonah
1833 Wenonah	
1835 Wenonah Ave	
1837 Wenonah Ave	
1845 WENONAH	



CITY OF BERWYN EVENT APPLICATION



K-15

Please provide information about your planned event:

Date of Event: 8/14, 2021 Time: Start 8am End 9pm

Type: Block Party Parade Open Air Event Use of Public Way

Description of Event: 1200 Kenilworth Block Party

Location of Event: 1200 Block of Kenilworth

Allowed Event Times

Block Parties
8AM to 9PM

All Other Events
8AM to 11PM

(Please print)

Name of Applicant: Joe Carmichael

Address: _____ Daytime Phone: _____

E-mail Address: _____ Alt. Phone: _____

Do you plan to use:

(Please mark all that apply)

- Live or Recorded Music Sound Equip. / Amplifiers Bounce Houses or Inflatables
- Food Vendors Commercial Food Prep. Equipment
- Crafter / Vendors Alcohol Sales Portable Toilets and Sanitation

Will you require any of the following City services? Yes No

* Please contact the Police Dept. for fee schedule if requesting Police Detail or Security.

- Street Closure Rolling Street Closure Alley Closure Parade Route Closure
- Barricades *Police Detail/Security Traffic Control ~~**Berwyn Public Library Book Peddler (Bike)~~
- **Fire Truck **McGruff **K-9 Unit **Police Explorers Unit

** These City services supplied only if available on the day of the event and subject to personnel availability

City Council Approval IS REQUIRED for your event. (City Council meets the 2nd & 4th Tuesday of every month)

- Submit this application to the Clerk's Office **8 weeks** prior to the event date.
- A Certificate of Insurance is required for Parades, Outdoor Events, Use of Public Way, as well as for all food and beverage sales.
- A Food License is required from the Berwyn Public Health Department for ALL food sales.
- A City of Berwyn Temporary Liquor License is required for ALL alcoholic beverage sales.
- A route map must be submitted with this application for all parades / demonstrations.
- USE OF PUBLIC WAY: Provide a list of intersections/corner locations and all dates being requested for use of public way. Location and Date availability is subject to approval. Use of public way is limited to one group per day, one group per location, and on a First Come—First Serve basis.
- The City reserves the right to regulate, restrict and limit use of the public way at all times.



Petition - Request for Block Party

This petition must list signatures of residents who represent at least 50% of the homeowners on the block YOU must notify ALL neighbors on the block - even those who did not sign the petition- of the block party date and time at least seven days in advance.

8 weeks prior to your Block Party date submit the completed petition along with a completed City of Berwyn Event Application and City Council Communication form to the Office of the Berwyn City Clerk so your application may be submitted to City Council for approval

Petition for Block Party

The undersigned, being residents of the 1200 block of Kenilworth, hereby request the City of Berwyn to close the aforementioned block to vehicular traffic on August 14, 2021 with a rain date of August 21, 2021 from the hours of 8:00 a.m. until 9:00 p.m.

ADDRESS:

1239 Kenilworth
1243 Kenilworth
1245 Kenilworth Ave
1237 Kenilworth
1235 Kenilworth
1231 Kenilworth
1215 Kenilworth
1214 Kenilworth
1222 KENILWORTH
1224 Kenilworth
1230 Kenilworth
1238 Kenilworth Ave #1
1244 KENILWORTH AVE
1247 KENILWORTH AVE

Redacted



City Council Communication – Request for Block Party

K-16

To: Mayor Robert J. Lovero and Members of the Berwyn City Council

From: Residents of the 27th 00 Block of GROVE AVE (i.e. 1200 Block of Home)

Date: 8-7-21

Re: Request for Block Party Approval

Dear Mayor Lovero and City Council:

The residents of the above listed street request approval for our Block Party to be held on:

Requested Date: 8-21-21, 2021 from 8:00 a.m. until 9:00 p.m.

Rain Date: 8-28-21, 2021 from 8:00 a.m. until 9:00 p.m.

We have also submitted the following forms with this request:

- Completed City of Berwyn Event Application, and
- A petition signed by at least 50% of the homeowners residing on our block.

I am the organizer of the Block Party. I have received and read the Berwyn Code of Ordinances regarding Block Parties ~~and Bounce Houses~~. My neighbors and I agree to abide by all the laws of the City of Berwyn and State of Illinois. In addition, we state that:

- We understand that the **use of fireworks is illegal** in Berwyn and in Illinois. We understand that our use of fireworks during our block party may result in the cancelling of our permit resulting in the ending of our party along with the possible issuance of tickets and fines.
- We also understand that Live Bands, DJ's or any amplified music must be kept at a reasonable level so as not to disturb other neighbors.
- We agree to clean up our block after the party.

As the permit holder, I understand that I am accepting responsibility for the activities conducted during the time of this permit. I also agree to notify all my neighbors of the date and time of the Block Party.

Thank you for considering our Block Party request,

Paul Iolis

Print Name

Address

Phone Number

E-mail Address

PLEASE RETURN TO THE OFFICE OF THE CITY CLERK 8 WEEKS PRIOR TO YOUR REQUESTED DATE
6700 W 26th St, Berwyn, IL 60402 Phone: 708-749-6452



CITY OF BERWYN EVENT APPLICATION



Please provide information about your planned event:

Date of Event: 8-21-21, 2021 Time: Start 2:00 PM End 10:00 PM

Allowed Event Times

Block Parties
8AM to 9PM

All Other Events
8AM to 11PM

Type: Block Party Parade Open Air Event Use of Public Way

Description of Event: Block Party

Location of Event: 2735 GROVE AVE BERWYN, IL

(Please print)

Name of Applicant: Paul Toris

Address: _____ Daytime Phone _____

E-mail Address: _____ Phone: _____

Do you plan to use: (Please mark all that apply)

Live or Recorded Music <input type="checkbox"/>	Sound Equip. / Amplifiers <input checked="" type="checkbox"/>	Bounce Houses or Inflatables <input type="checkbox"/>
	Food Vendors <input type="checkbox"/>	Commercial Food Prep. Equipment <input type="checkbox"/>
Crafter / Vendors <input checked="" type="checkbox"/>	Alcohol Sales <input type="checkbox"/>	Portable Toilets and Sanitation <input type="checkbox"/>

Will you require any of the following City services? Yes No

* Please contact the Police Dept. for fee schedule if requesting Police Detail or Security.

** These City services supplied only if available on the day of the event and subject to personnel availability

Street Closure <input checked="" type="checkbox"/>	Rolling Street Closure <input checked="" type="checkbox"/>	Alley Closure <input type="checkbox"/>	Parade Route Closure <input type="checkbox"/>
Barricades <input checked="" type="checkbox"/>	*Police Detail/Security <input type="checkbox"/>	Traffic Control <input type="checkbox"/>	**Berwyn Public Library Book Peddler (Bike) <input type="checkbox"/>
**Fire Truck <input checked="" type="checkbox"/>	**McGruff <input checked="" type="checkbox"/>	**K-9 Unit <input type="checkbox"/>	**Police Explorers Unit <input type="checkbox"/>

City Council Approval IS REQUIRED for your event. (City Council meets the 2nd & 4th Tuesday of every month)

- Submit this application to the Clerk's Office **8 weeks** prior to the event date.
- A Certificate of Insurance is required for Parades, Outdoor Events, Use of Public Way, as well as for all food and beverage sales.
- A Food License is required from the Berwyn Public Health Department for ALL food sales.
- A City of Berwyn Temporary Liquor License is required for ALL alcoholic beverage sales.
- A route map must be submitted with this application for all parades / demonstrations.
- USE OF PUBLIC WAY: Provide a list of intersections/corner locations and all dates being requested for use of public way. Location and Date availability is subject to approval. Use of public way is limited to one group per day, one group per location, and on a First Come—First Serve basis.
- The City reserves the right to regulate, restrict and limit use of the public way at all times.



Petition -- Request for Block Party

This petition must list signatures of residents who represent at least 50% of the homeowners on the block. YOU must notify ALL neighbors on the block - even those who did not sign the petition- of the block party date and time at least seven days in advance.

8 weeks prior to your Block Party date submit the completed petition along with a completed City of Berwyn Event Application and City Council Communication form to the Office of the Berwyn City Clerk so your application may be submitted to City Council for approval.

Petition for Block Party

The undersigned, being residents of the 27TH block of Grove, hereby request the City of Berwyn to close the aforementioned block to vehicular traffic on 21ST with a rain date of 28TH from the hours of 8:00 a.m. until 9:00 p.m.

NAME:

ADDRESS:

Redacted

2735 Grove
2745 Grove
2739 Grove
2733 Grove
2729 Grove
2723 Grove
2721 Grove
2719 Grove Ave
2715 Grove Ave
2711 Grove Ave
2705 Grove Ave
2703 Grove Ave
2700 Grove Ave
2706 Grove Ave.
2712 Grove Ave
2718 Grove Ave
2724 Grove Ave.
2720 Grove Ave
2736 Grove Ave



Petition - Request for Block Party

This petition must list signatures of residents who represent at least 50% of the homeowners on the block. YOU must notify ALL neighbors on the block - even those who did not sign the petition- of the block party date and time at least seven days in advance.

8 weeks prior to your Block Party date submit the completed petition along with a completed City of Berwyn Event Application and City Council Communication form to the Office of the Berwyn City Clerk so your application may be submitted to City Council for approval.

Petition for Block Party

The undersigned, being residents of the _____ block of _____, hereby request the City of Berwyn to close the aforementioned block to vehicular traffic on _____ with a rain date of _____ from the hours of 8:00 a.m. until 9:00 p.m.

NAME

ADDRESS:

Redacted

2734 Grove Ave
2728 Grove Ave

K-17

Margaret M. Paul

From: Donnie Biggins <donnie@fitzgeraldsnightclub.com>
Sent: Tuesday, July 6, 2021 11:16 PM
To: Margaret M. Paul
Subject: FITZGERALDS - BERWYN BLUES FESTIVAL - STREET CLOSURE REQUEST + APPLICATION
Attachments: FitzgeraldsBerwynBluesFestival_event.pdf

Hi Ms. Paul,

FITZGERALDS asks permission to hold its inaugural Berwyn Blues Festival on September 24th - September 26th, 2021 featuring live music outside on our patio with a tent and inside our nightclub. Music will end by 10PM outside each evening.

We are also asking to close Clarence Avenue from the Alley to the driveway of the Berwyn Town Mall - approximately 70 feet to provide performing artists with additional parking space and picnic tables.

We have always done this for the previous American Music Festivals. Though the Blues Festival will not be the same as American Music Festival, we hope to build it for years to come as another great way to provide a weekend attraction to Berwyn.

Thank you,
Donnie Biggins

--
DONNIE BIGGINS (he/him)
Head of Music
office (708) 788-2118



NOTICE: EXTERNAL EMAIL

This email was sent to you from outside the City of Berwyn network.

- * If this message concerns your ILLINOIS DRIVERS LICENSE, SOCIAL SECURITY, DEPT OF LABOR, or IDES/UNEMPLOYMENT ASSISTANCE, it is most likely fraudulent. Delete immediately.
- * Do not rely on the sender's name to verify this message's legitimacy.
- * Please verify the sender's email address is legitimate before opening attachments or links.
- * Use caution when opening attachments or links from unknown senders.
- * Contact the HelpDesk before clicking links or opening attachments if you need to confirm this message's legitimacy.
- * The HelpDesk will never send external emails, so if you are reading this disclaimer on an email from HelpDesk or any other IT support, it is not genuine.



CITY OF BERWYN EVENT APPLICATION



Please provide information about your planned event:

Date of Event: 9/24 - 9/26, 2021 Time: Start 9/24 @ 5, 9/25 & 26 @ 12 End 11PM

Allowed Event Times

Block Parties
8AM to 9PM

All Other Events
8AM to 11PM

Type: Block Party Parade Open Air Event Use of Public Way

Description of Event: FITZGERALDS BERWYN BLUES FESTIVAL

Location of Event: FITZGERALDS - 6615 W. ROOSEVELT ROAD

(Please print)

Name of Applicant: DONNIE BIGGINS ON BEHALF OF FITZGERALDS

Address: 6615 W. ROOSEVELT ROAD Daytime Phone:

E-mail Address: DONNIE@FITZGERALDSNIGHTCLUB.COM Alt. Phone:

Do you plan to use:

(Please mark all that apply)

- | | | |
|--|---|--|
| Live or Recorded Music <input checked="" type="checkbox"/> | Sound Equip. / Amplifiers <input checked="" type="checkbox"/> | Bounce Houses or Inflatables <input type="checkbox"/> |
| | Food Vendors <input type="checkbox"/> | Commercial Food Prep. Equipment <input type="checkbox"/> |
| Crafter / Vendors <input type="checkbox"/> | Alcohol Sales <input checked="" type="checkbox"/> | Portable Toilets and Sanitation <input type="checkbox"/> |

Will you require any of the following City services? Yes No

* Please contact the Police Dept. for fee schedule if requesting Police Detail or Security.

** These City services supplied only if available on the day of the event and subject to personnel availability

- | | | | |
|--|--|--|--|
| Street Closure <input checked="" type="checkbox"/> | Rolling Street Closure <input type="checkbox"/> | Alley Closure <input type="checkbox"/> | Parade Route Closure <input type="checkbox"/> |
| Barricades <input checked="" type="checkbox"/> | *Police Detail/Security <input type="checkbox"/> | Traffic Control <input type="checkbox"/> | **Berwyn Public Library Book Peddler (Bike) <input type="checkbox"/> |
| **Fire Truck <input type="checkbox"/> | **McGruff <input type="checkbox"/> | **K-9 Unit <input type="checkbox"/> | **Police Explorers Unit <input type="checkbox"/> |

City Council Approval IS REQUIRED for your event. (City Council meets the 2nd & 4th Tuesday of every month)

- **Submit this application to the Clerk's Office 8 weeks prior to the event date.**
- A Certificate of Insurance is required for Parades, Outdoor Events, Use of Public Way, as well as for all food and beverage sales.
- A Food License is required from the Berwyn Public Health Department for ALL food sales.
- A City of Berwyn Temporary Liquor License is required for ALL alcoholic beverage sales.
- A route map must be submitted with this application for all parades / demonstrations.
- **USE OF PUBLIC WAY:** Provide a list of intersections/corner locations and all dates being requested for use of public way. Location and Date availability is subject to approval. Use of public way is limited to one group per day, one group per location, and on a First Come—First Serve basis.
- **The City reserves the right to regulate, restrict and limit use of the public way at all times.**

Roosevelt Rd

W Roosevelt Rd

Roosev

Clarence Ave

Clarence Ave

Clarence Ave

The Wing Boss
Takeout • Delivery

6629 6627 6623

Di Nicos Pizza
Takeout • Delivery

6619 6615 6617
FitzGerald's ATM

ATM

Babygold B
Take

6611

Capri Risto
Takeout • D

6615

1212

1218

Google

Map data ©2021 Map data ©2021 United States Terms Privacy Send feed



CITY OF BERWYN EVENT APPLICATION



K-18

Please provide information about your planned event:

Date of Event: Once a month until fall, 2021 Time: Start 9:00AM End 4:00PM

Allowed Event Times

Block Parties
8AM to 9PM

All Other Events
8AM to 11PM

Type: Block Party Parade Open Air Event Use of Public Way

Description of Event: Garage Sale for Break The Silence Foundation

Location of Event: 6635 W. Cermak Rd. Berwyn, IL 60402

(Please print)

Name of Applicant: Maribel Garcia

Address: 6635 W. Cermak Rd. Berwyn, IL 60402 Daytime Phone: _____

E-mail Address: mgarcia@btsfinc.org Alt. Phone: _____

Do you plan to use: (Please mark all that apply)

Live or Recorded Music <input type="checkbox"/>	Sound Equip. / Amplifiers <input type="checkbox"/>	Bounce Houses or Inflatables <input type="checkbox"/>
	Food Vendors <input type="checkbox"/>	Commercial Food Prep. Equipment <input type="checkbox"/>
Crafter / Vendors <input type="checkbox"/>	Alcohol Sales <input type="checkbox"/>	Portable Toilets and Sanitation <input type="checkbox"/>

Will you require any of the following City services? Yes No

* Please contact the Police Dept. for fee schedule if requesting Police Detail or Security.

Street Closure <input type="checkbox"/>	Rolling Street Closure <input type="checkbox"/>	Alley Closure <input type="checkbox"/>	Parade Route Closure <input type="checkbox"/>
Barricades <input type="checkbox"/>	*Police Detail/ Security <input type="checkbox"/>	Traffic Control <input type="checkbox"/>	**Berwyn Public Library Book Peddler (Bike) <input type="checkbox"/>
**Fire Truck <input type="checkbox"/>	**McGruff <input type="checkbox"/>	**K-9 Unit <input type="checkbox"/>	**Police Explorers Unit <input type="checkbox"/>

** These City services supplied only if available on the day of the event and subject to personnel availability

City Council Approval IS REQUIRED for your event. (City Council meets the 2nd & 4th Tuesday of every month)

- Submit this application to the Clerk's Office **8 weeks** prior to the event date.
- A Certificate of Insurance is required for Parades, Outdoor Events, Use of Public Way, as well as for all food and beverage sales.
- A Food License is required from the Berwyn Public Health Department for ALL food sales.
- A City of Berwyn Temporary Liquor License is required for ALL alcoholic beverage sales.
- A route map must be submitted with this application for all parades / demonstrations.
- USE OF PUBLIC WAY: Provide a list of intersections/corner locations and all dates being requested for use of public way. Location and Date availability is subject to approval. Use of public way is limited to one group per day, one group per location, and on a First Come—First Serve basis.
- The City reserves the right to regulate, restrict and limit use of the public way at all times.

Margaret M. Paul

From: Maribel Garcia <mgarcia@btsfinc.org>
Sent: Thursday, July 8, 2021 4:00 PM
To: Margaret M. Paul
Subject: Re: Break the Silence Foundation Event Request

Hi Margaret:

Thank you for replying.

1) Yes our "Garage Sale" will be held inside our offices at 6635 Cermak Rd. This is to raise funds for our domestic violence program.

2) The sale items will be inside the premises. We will not be using the sidewalk.

3) We need just one weekend a month until fall, starting August, September and October.

Margaret, I want to thank you in advance for all you can do to help our beautiful and noble mission.

On Thu, 8 Jul 2021 17:17:44 +0000, "Margaret M. Paul" <MPaul@ci.berwyn.il.us> wrote:

Hello Ms. Garcia: We received your event request to be placed on the City Council agenda for July 13, 2021. We need clarification prior to placing it before the council. Please provide the following information:

You are requesting permission for a Garage Sale. I note that the foundation is located in the BMO Harris Bank building at 6635 Cermak Road. Your request does not fall within the City of Berwyn Ordinance definition of a garage sale/casual sale taking place on residential property. What garage will you be using for the intended monthly sale?

2. If you are not using a garage, where will your sale be held? Will your sale be held inside at 6635 Cermak?
3. Will any of the sale items be displayed on the sidewalk in front of 6635 Cermak?
4. You did not indicate what day of the week you intend to hold your sale on a monthly basis. Please advise the day of the week this will take place.
5. Please indicate the specific months you will be holding the sale indicating the starting month and ending month.

Thank you for providing the information above. We will include your answers with your event application to the City Council for consideration.

Margaret Paul, Berwyn City Clerk

(She, Her, Her's)

6700 W. 26th St.

Berwyn, IL 60402

708-749-6451

NOTICE: EXTERNAL EMAIL

This email was sent to you from outside the City of Berwyn network.

- * If this message concerns your ILLINOIS DRIVERS LICENSE, SOCIAL SECURITY, DEPT OF LABOR, or IDES/UNEMPLOYMENT ASSISTANCE, it is most likely fraudulent. Delete immediately.
- * Do not rely on the sender's name to verify this message's legitimacy.
- * Please verify the sender's email address is legitimate before opening attachments or links.
- * Use caution when opening attachments or links from unknown senders.
- * Contact the HelpDesk before clicking links or opening attachments if you need to confirm this message's legitimacy.
- * The HelpDesk will never send external emails, so if you are reading this disclaimer on an email from HelpDesk or any other IT support, it is not genuine.